

PART NUMBER	REVISION	DESCRIPTION	FEED TYPE
2150240-2	D	FINE CRIMP HEIGHT ADJUST	PNEUMATIC
7-2150240-2	D	PNEUMATIC AND CRIMP TOOLING KIT	PNEUMATIC
7-2150240-7	A	CRIMP TOOLING KIT	-

ATLANTIC VERSION TERMINATOR INTERFACE ADAPTER

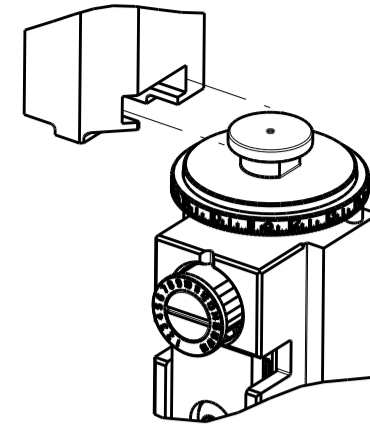

APPLICATOR DATA		
CRIMP	SIZE	TYPE
WIRE	3.81 mm [.150]	F
INSUL	5.59 mm [.220]	F
APPL INSTRUCTIONS 408-35043		

TERMINAL DATA: TE TERMINAL		TE CRIMP SPECIFICATION
TERMINAL NAME: 250 SERIES POSITIVE LOCK MARK II RECEP		
WIRE STRIP LENGTH 5.50-6.50 mm [.217-.256 IN]		INSULATION DIAMETER RANGE Ø3.00-5.10 mm [.118-.201 IN]
TERMINAL APPLICATION SPECIFICATION 114-5042		-
TERMINALS APPLIED		
TE TERMINAL	TE TERMINAL	TE TERMINAL
170329-1		

WIRE SIZE	CRIMP HEIGHT mm [INCH]	CRIMP HEIGHT REFERENCE SETTING
5.00mm2	2.58 +/- 0.05 [.102 +/- .002]	1.4
3.00mm2	2.20 +/- 0.05 [.087 +/- .002]	5.1
2.00mm2	1.83 +/- 0.05 [.072 +/- .002]	9.5
1.3+0.5+0.5mm2	1.83 +/- 0.05 [.072 +/- .002]	9.5
1.25+0.5mm2	1.79 +/- 0.05 [.070 +/- .002]	9.9



- RECOMMENDED SPARE PARTS
- REFER TO SUPPLIED INSTRUCTION SHEET FOR CLEANING, LUBRICATION AND STORAGE OF APPLICATOR.
- APPLY PART NUMBER 2-23419-6 LOCTITE TO THREADS OF ITEM 242. APPLY PART NUMBER 1-23419-5 LOCTITE TO THREADS OF ITEM 50.
- CRIMP HEIGHT REFERENCE SETTING WAS THE SETTING USED WHEN THE APPLICATOR WAS QUALIFIED AT THE FACTORY. ADJUSTMENT MAY BE NECESSARY WHEN RUNNING APPLICATOR IN THE FIELD.
- WIRE STRIP LENGTH 5.80-6.80 mm [.228-.268 IN]
- UNLESS SPECIFIED OTHERWISE TORQUE VALUES SHALL BE USED PER DOCUMENT, 101-35000.
- TERMINAL DESIGN IS NOT COMPATIBLE WITH MECHANICAL FEED.

***WARNING**
ON INSTALLATION, SET WIRE DISC TO CRIMP HEIGHT REFERENCE SETTING FOR LARGEST WIRE SIZE. CRIMP HEIGHT REFERENCE SETTINGS GREATER THAN THE VALUE SHOWN MAY CAUSE DAMAGE TO THE CRIMP TOOLING. REFER TO THE INSTRUCTION SHEET FOR PROPER SETUP AND ADJUSTMENTS.

ATLANTIC VERSION
Shown on sheets 1 of 4 & 2 of 4
(Pacific version shown on sheets 3 of 4 & 4 of 4)

LOC	DIST	REV	LTN	DESCRIPTION	DATE	OWN	APVD
A	66	-	-	RELEASED	01JUN2012	RK	GB
-	-	B	-	ECR-18-014354	10SEP2018	TB	TE
-	-	C	-	ECR-20-000907	17JAN2020	JAH	RK
-	-	D	-	ECR-20-004154	19MAR2020	FZ	RK

-	1	1	2119641-1	FEED CAM, AIR FEED	248	
-	1	1	2119082-9	CAM, SNAIL, INSULATION ADJUSTMENT	244	
-	1	1	2079764-1	WASHER, WAVE SPRING, CREST-TO-CREST	243	
-	1	1	2119083-1	RETAINER, INSULATION DIAL	242	
-	1	1	2844940-4	AIR FEED MODULE	238	
-	1	1	1-18028-0	WASHER, FLAT, REG M8	192	
-	1	1	6-993111-6	PIN, SLOTTED SPRING 3.0 X 14.0	177	
-	1	1	8-22280-7	SPRING, COMPRESSION	176	
-	1	1	1752353-2	GUIDE PIN, HOLDDOWN	175	
-	1	1	1901680-2	GUIDE PIN, HOLDDOWN	174	
-	REF	REF	994970-2	COUNTER, MAGNETIC	164	
-	1	1	455888-5	SPACER, CRIMPER	82	
-	1	1	1803607-4	DOCUMENTATION PACKAGE	71	
-	2	2	2-18032-2	SCR, SET, FLT PNT, M3 X 10.0	70	
-	1	1	2119943-1	WASHER, SPACER	69	
-	1	1	2119740-1	TAG, IDENTIFICATION	67	
-	2	2	2168078-1	SCREW, DRIVE, RH, RoHS, 2 x .188	66	
-	1	1	1976052-1	HOLDDOWN, TERMINAL	65	
-	2	2	2168400-5	SHCS, LOW HEAD, RoHS, M4 X 20	64	
-	1	1	2168083-2	SCR, SKT HD CAP, RoHS, M4 X 8.0	60	
-	1	1	5-18022-5	SCR, HEX HD CAP, M4 X 6.0	59	
-	3	3	2168400-4	SHCS, LOW HEAD, RoHS, M4 X 8	57	
-	2	2	2168083-8	SCR, SKT HD CAP, RoHS, M4 X 16	56	
-	2	2	5018030-1	NUT, HEX, REG, RoHS, M3	54	
-	2	2	986965-8	NUT, LOCK, HEX, TORQUE (M4)	53	
-	1	1	1-5018030-0	NUT, HEX, REG, RoHS, M3.5	52	
-	1	1	2063961-1	FEED FINGER	51	
-	1	1	1-1752354-1	STANDOFF, HOLD-DOWN	50	
-	1	1	18023-9	SCR, SKT HD CAP M4 X 6.0	49	
-	1	1	2119655-5	APPLICATOR BASIC ASSEMBLY, EF	46	
-	1	1	1803517-1	RAM ASSEMBLY, EF ATLANTIC	44	
-	1	1	1803602-1	SCR, BHSC, RoHS (M8 X 25)	41	
-	7	7	1-18028-2	WASHER, FLAT, REG M4	33	
-	2	2	2168083-9	SCR, SKT HD CAP, RoHS, M4 X 20	31	
-	2	2	2168083-2	SCR, SKT HD CAP, RoHS, M4 X 8.0	29	
-	1	1	240639-1	STRIPPER (MACHINING)	27	
-	2	2	1-2168083-5	SCR, SKT HD CAP, RoHS, M4 X 30	25	
-	1	1	1-1752371-7	PLATE, STRIP GUIDE	24	
-	1	1	240825-2	PLATE, STRIP HOLD DOWN	23	
-	2	2	2-22281-3	SPRING, COMPRESSION	22	
-	1	1	1803292-1	DRAG	20	
-	2	2	1901259-6	GUIDE, LOWER STRIP	18	
-	4	4	1-2079383-1	SCR, BHSC, RoHS (M6 X 12)	17	
-	1	1	3-240641-8	SPACER	16	
-	1	1	1752360-1	SPACER, HOLD-DOWN	13	
-	1	1	240833-7	PLATE, REAR SHEAR	11	
-	-	-	-	-	10	
-	1	1	6-690482-3	PLATE, FRONT SHEAR	9	
-	1	2	1	1633386-6	ANVIL, COMBINATION	8
-	1	1	1	1-690474-7	BLADE, SLUG	7
-	1	1	1	5-240641-3	SPACER	5
-	1	1	1	238011-2	BLOCK, CRIMPER SPACER	4
-	1	2	1	1-1633962-4	CRIMPER, INSULATION F PREMIUM	3
-	1	1	1	1-455888-4	SPACER, CRIMPER	2
-	1	2	1	6-1633305-3	CRIMPER, WIRE PREMIUM	1
-	77	72	2	PART NO	DESCRIPTION	ITEM NO

DIMENSIONS:		TOLERANCES UNLESS OTHERWISE SPECIFIED:		DRAWING NO	
mm	0 PLC ±	1 PLC ±	2 PLC ±	3 PLC ±	4 PLC ±
	ANGLES				
MATERIAL	FINISH	WEIGHT	SCALE	SHEET	REV
-	-	-	A1 00779 ©=2150240	1 OF 4	D

LOC	DIST	REV	DATE	BY	APPV
A	66				
		DESCRIPTION	DATE	BY	APPV
		SEE SHEET 1			

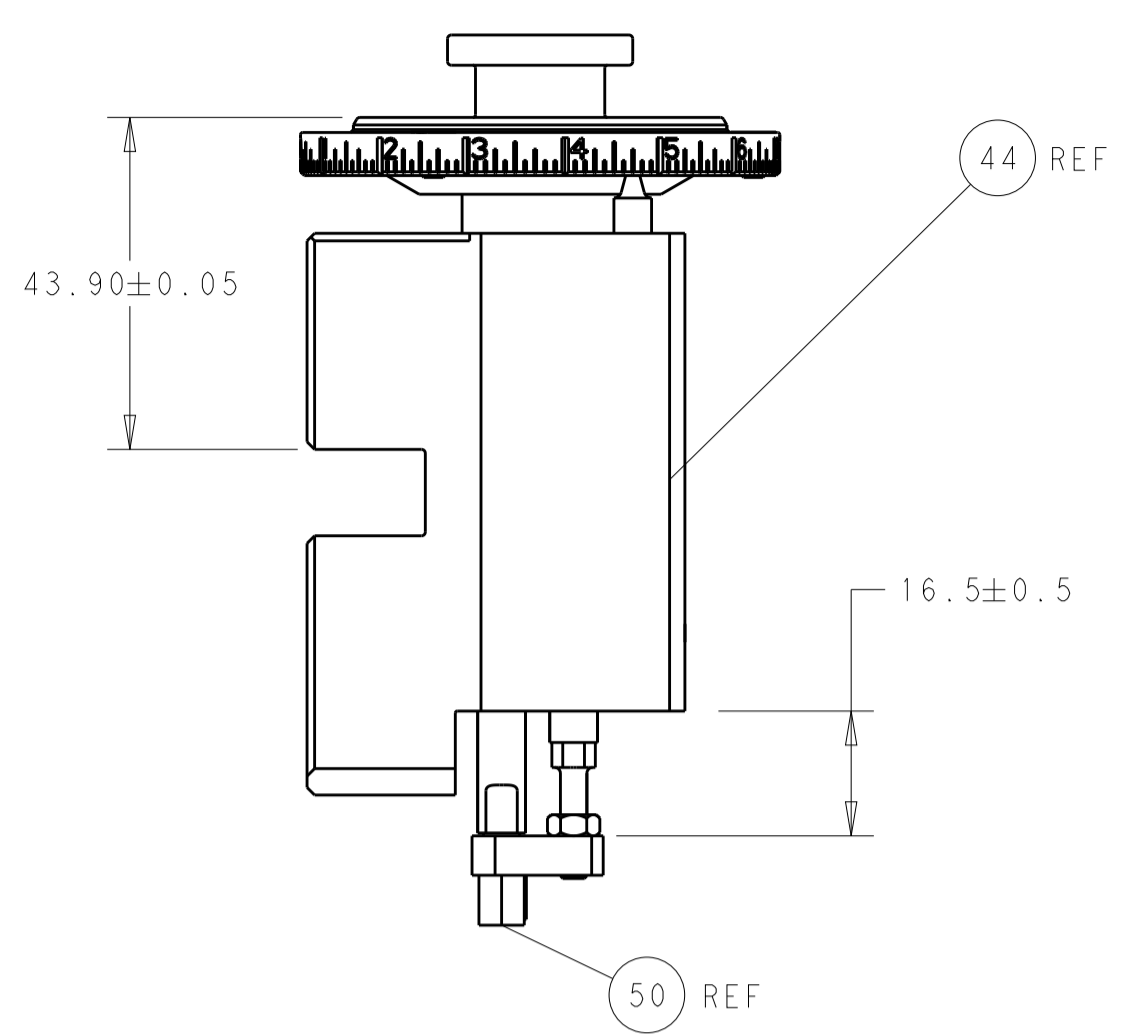

RAM AND HOLDDOWN SET-UP

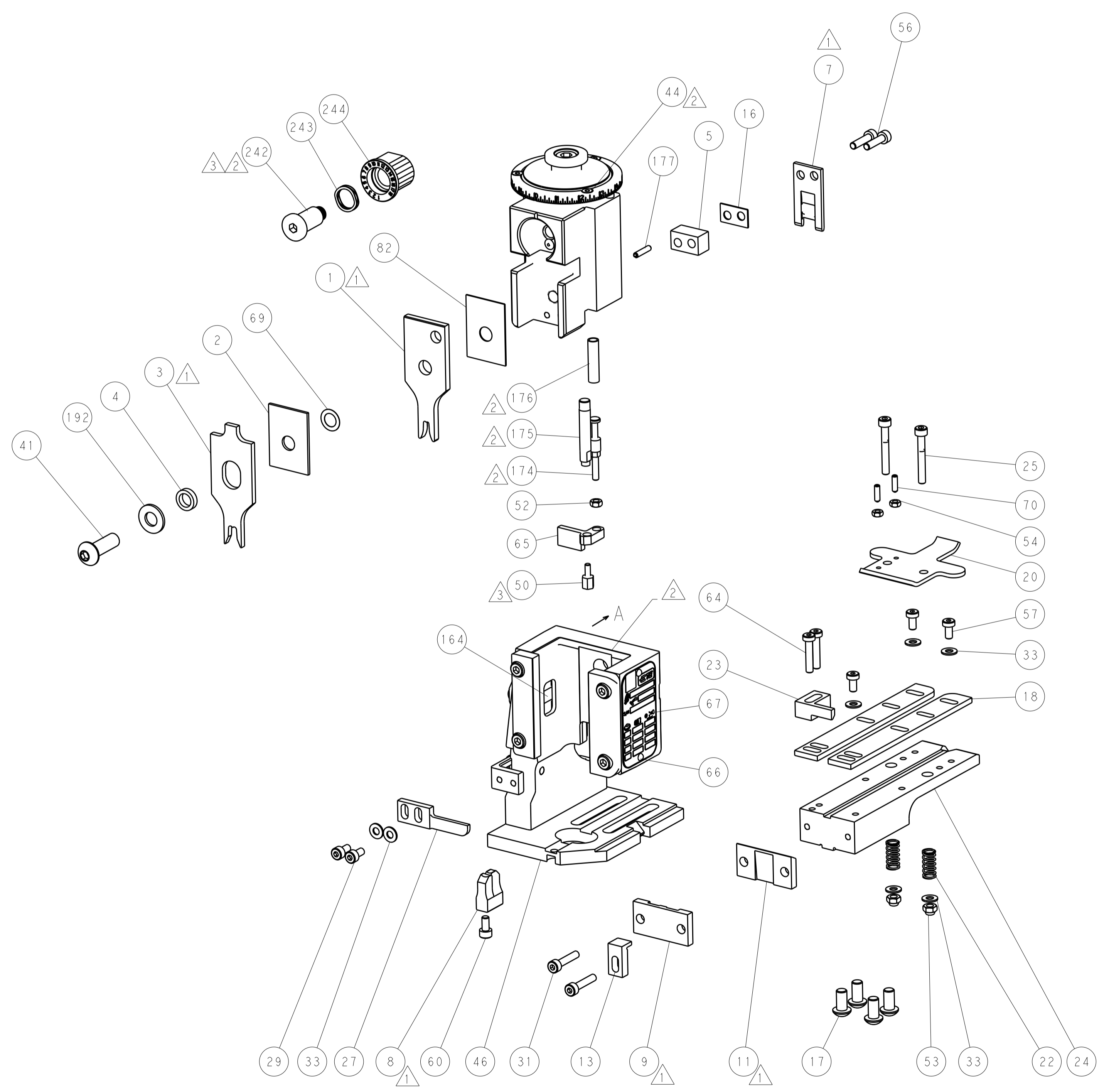

FEED TYPE

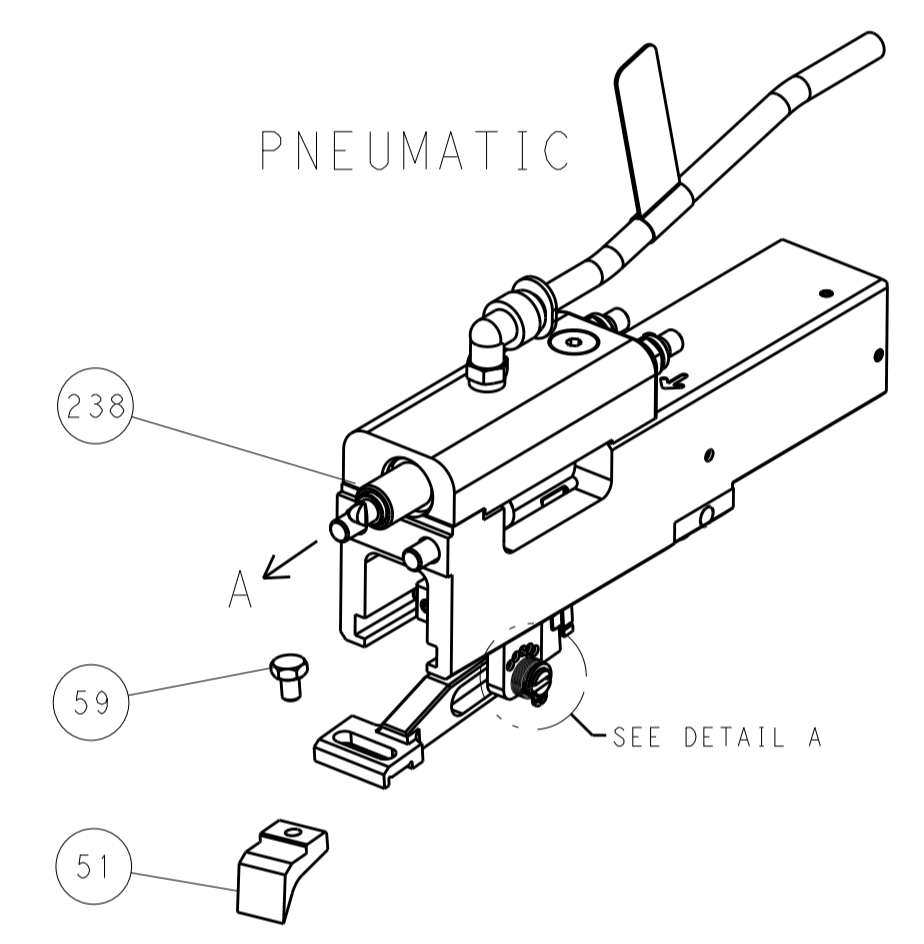

FEED SPRING SETTING POSITION

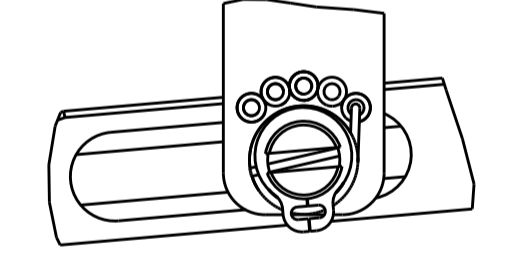

DETAIL A

CAM POSITIONS

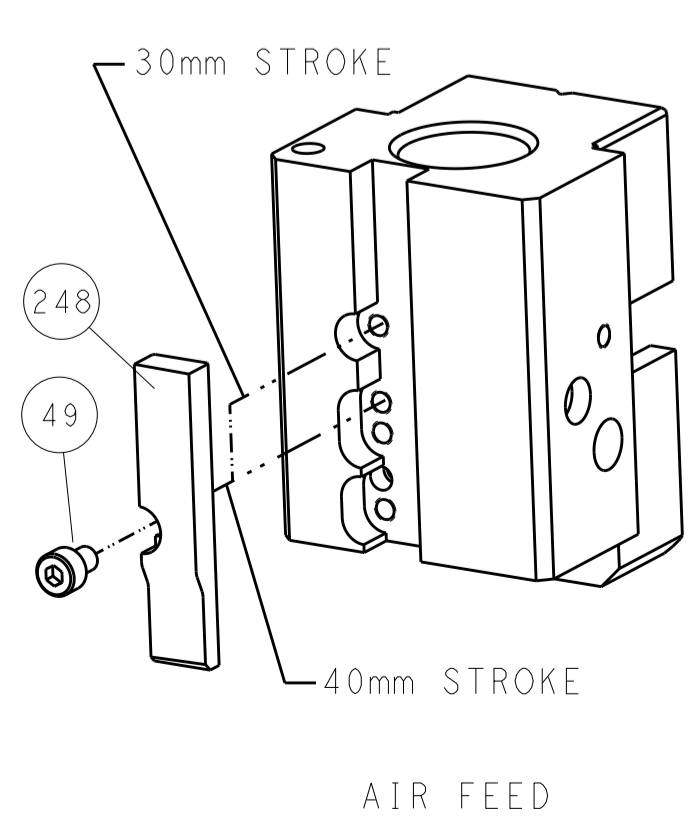

AIR FEED

ATLANTIC VERSION
 Shown on sheets 1 of 4 & 2 of 4
 (Pacific version shown on sheets 3 of 4 & 4 of 4)

DIMENSIONS: mm 		TOLERANCES UNLESS OTHERWISE SPECIFIED: 0 PLC ± 1 PLC ± 2 PLC ± 3 PLC ± 4 PLC ± ANGLES ±		DWN R. KNEPPER 02APR2012 CHK T. ELBIN 02APR2012 APVD M. CLIFFORD 02APR2012 PRODUCT SPEC APPLICATION SPEC WEIGHT CUSTOMER ACCESSIBLE PRODUCTION DRAWING		NAME Ocean End Feed Applicator SIZE CAGE CODE DRAWING NO A1 00779 C=2150240 SCALE 1:1 SHEET 2 OF 4 REV D		RESTRICTED TO	
SHEETS 3 & 4 ARE NOT REQUIRED FOR ATLANTIC VERSION									

PACIFIC VERSION TERMINATOR
 INTERFACE ADAPTER

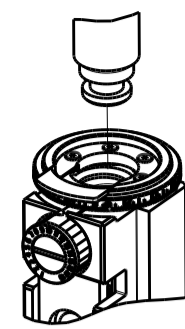

PART NUMBER	REVISION	DESCRIPTION	FEED TYPE
2-2150240-2	D	FINE CRIMP HEIGHT ADJUST	PNEUMATIC
7-2150240-7	A	CRIMP TOOLING KIT	-

APPLICATOR DATA		
CRIMP	SIZE	TYPE
WIRE	3.81 mm [.150]	F
INSUL	5.59 mm [.220]	F
APPL INSTRUCTIONS 408-35043		

TERMINAL DATA: TE TERMINAL		TE CRIMP SPECIFICATION	
TERMINAL NAME: 250 SERIES POSITIVE LOCK MARK II RECP			
WIRE STRIP LENGTH		INSULATION DIAMETER RANGE	
5.50-6.50 mm [.217-.256 IN]		3.00-5.10 mm [.118-.201 IN]	
TERMINAL APPLICATION SPECIFICATION		114-5042	
TERMINALS APPLIED			
TE TERMINAL	TE TERMINAL	TE TERMINAL	TE TERMINAL
170329-1			

WIRE SIZE	CRIMP HEIGHT mm [INCH]	CRIMP HEIGHT REFERENCE SETTING
5.00mm2	2.58 +/- 0.05 [.102 +/- .002]	1.4
3.00mm2	2.20 +/- 0.05 [.087 +/- .002]	5.1
2.00mm2	1.83 +/- 0.05 [.072 +/- .002]	9.5
1.3+0.5+0.5mm2	1.83 +/- 0.05 [.072 +/- .002]	9.5
1.25+0.5mm2	1.79 +/- 0.05 [.070 +/- .002]	9.6

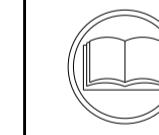

- RECOMMENDED SPARE PARTS
- REFER TO SUPPLIED INSTRUCTION SHEET FOR CLEANING, LUBRICATION AND STORAGE OF APPLICATOR.
- APPLY PART NUMBER 2-23419-6 LOCTITE TO THREADS OF ITEM 242. APPLY PART NUMBER 1-23419-5 LOCTITE TO THREADS OF ITEM 50.
- CRIMP HEIGHT REFERENCE SETTING WAS THE SETTING USED WHEN THE APPLICATOR WAS QUALIFIED AT THE FACTORY. ADJUSTMENT MAY BE NECESSARY WHEN RUNNING APPLICATOR IN THE FIELD.
- WIRE STRIP LENGTH 5.80-6.80 mm [.228-.268 IN]
- UNLESS SPECIFIED OTHERWISE TORQUE VALUES SHALL BE USED PER DOCUMENT, 101-35000.
- TERMINAL DESIGN IS NOT COMPATIBLE WITH MECHANICAL FEED.

***WARNING**
 ON INSTALLATION, SET WIRE DISC TO CRIMP HEIGHT REFERENCE SETTING FOR LARGEST WIRE SIZE. CRIMP HEIGHT REFERENCE SETTINGS GREATER THAN THE VALUE SHOWN MAY CAUSE DAMAGE TO THE CRIMP TOOLING. REFER TO THE INSTRUCTION SHEET FOR PROPER SETUP AND ADJUSTMENTS.

LOC	DIST	REVISIONS					
		P	LTN	DESCRIPTION	DATE	OWN	APPD
A	66	-	-	SEE SHEET 1	-	-	-

- 1	2119082-9	CAM, SNAIL, INSULATION ADJUSTMENT	244
- 1	2079764-1	WASHER, WAVE SPRING, CREST-TO-CREST	243
- 1	2119083-1	RETAINER, INSULATION DIAL	242
- 1	2844940-4	AIR FEED MODULE	238
- 1	1-18028-0	WASHER, FLAT, REG M8	192
- 4	2079383-9	SCR, BHSC, RoHS (M6 X 20)	186
- 1	6-993111-6	PIN, SLOTTED SPRING 3.0 X 14.0	177
- 1	8-22280-7	SPRING, COMPRESSION	176
- 1	1752353-2	GUIDE PIN, HOLDDOWN	175
- 1	1901680-2	GUIDE PIN, HOLDDOWN	174
- REF	994970-2	COUNTER, MAGNETIC	164
- 1	2119641-2	FEED CAM, AIR FEED	152
- 1	2168083-8	SCR, SKT HD CAP, RoHS, M4 X 16	144
- 1	2119655-6	APPLICATOR BASIC ASSEMBLY, EF	141
- 1	1803518-1	RAM ASSEMBLY, EF PACIFIC	140
- 1	455888-5	SPACER, CRIMPER	82
- 1	1803607-4	DOCUMENTATION PACKAGE	71
- 2	2-18032-2	SCR, SET, FLT PNT, M3 X 10.0	70
- 1	2119943-1	WASHER, SPACER	69
- 1	2119740-1	TAG, IDENTIFICATION	67
- 2	2168078-1	SCREW, DRIVE, RH, RoHS, 2 x .188	66
- 1	1976052-1	HOLDDOWN, TERMINAL	65
- 2	2168400-5	SHCS, LOW HEAD, RoHS, M4 X 20	64
- 1	5-18022-5	SCR, HEX HD CAP, M4 X 6.0	59
- 3	2168400-4	SHCS, LOW HEAD, RoHS, M4 X 8	57
- 2	2168083-8	SCR, SKT HD CAP, RoHS, M4 X 16	56
- 2	5018030-1	NUT, HEX, REG, RoHS, M3	54
- 2	986965-8	NUT, LOCK, HEX, TORQUE (M4)	53
- 1	1-5018030-0	NUT, HEX, REG, RoHS, M3.5	52
- 1	2063961-1	FEED FINGER	51
- 1	1-1752354-1	STANDOFF, HOLD-DOWN	50
- 1	18023-9	SCR, SKT HD CAP M4 X 6.0	49
- 1	1803602-1	SCR, BHSC, RoHS (M8 X 25)	41
- 7	1-18028-2	WASHER, FLAT, REG M4	33
- 2	2168083-9	SCR, SKT HD CAP, RoHS, M4 X 20	31
- 2	2168083-2	SCR, SKT HD CAP, RoHS, M4 X 8.0	29
- 1	240639-1	STRIPPER (MACHINING)	27
- 2	1-2168083-5	SCR, SKT HD CAP, RoHS, M4 X 30	25
- 1	1-1752371-7	PLATE, STRIP GUIDE	24
- 1	240825-2	PLATE, STRIP HOLD DOWN	23
- 2	2-22281-3	SPRING, COMPRESSION	22
- 1	1803292-1	DRAG	20
- 2	1901259-6	GUIDE, LOWER STRIP	18
- 1	3-240641-8	SPACER	16
- 1	1752360-1	SPACER, HOLD-DOWN	13
- 1	240833-7	PLATE, REAR SHEAR	11
- -	-	-	10
- 1	6-690482-3	PLATE, FRONT SHEAR	9
1 1	1633386-6	ANVIL, COMBINATION	8
- 1	1-690474-7	BLADE, SLUG	7
- 1	5-240641-3	SPACER	5
- 1	238011-2	BLOCK, CRIMPER SPACER	4
1 1	1-1633962-4	CRIMPER, INSULATION F PREMIUM	3
- 1	1-455888-4	SPACER, CRIMPER	2
1 1	6-1633305-3	CRIMPER, WIRE PREMIUM	1
- 77-22	PART NO	DESCRIPTION	ITEM NO

PACIFIC VERSION
 Shown on sheets 3 of 4 & 4 of 4
 (Atlantic version shown on sheets 1 of 4 & 2 of 4)

DIMENSIONS: mm 		TOLERANCES UNLESS OTHERWISE SPECIFIED: 0 PLC ±. 1 PLC ±. 2 PLC ±. 3 PLC ±. 4 PLC ±. ANGLES ±. FINISH		DWN R. KNEPPER 02APR2012 CHK T. ELBIN 02APR2012 APVD M. CLIFFORD 02APR2012	STE TE Connectivity Harrisburg, PA 17105-3608	
MATERIAL:		FINISH:		NAME: Ocean End Feed Applicator		SIZE: A1 CAGE CODE: 00779 DRAWING NO: C=2150240
CUSTOMER ACCESSIBLE PRODUCTION DRAWING		SCALE: 1:1		SHEET 3 OF 4		REV D

LOC		DIST		REVISIONS			
A	66	P	LTM	DESCRIPTION	DATE	DWN	APVD
		-		SEE SHEET 1			

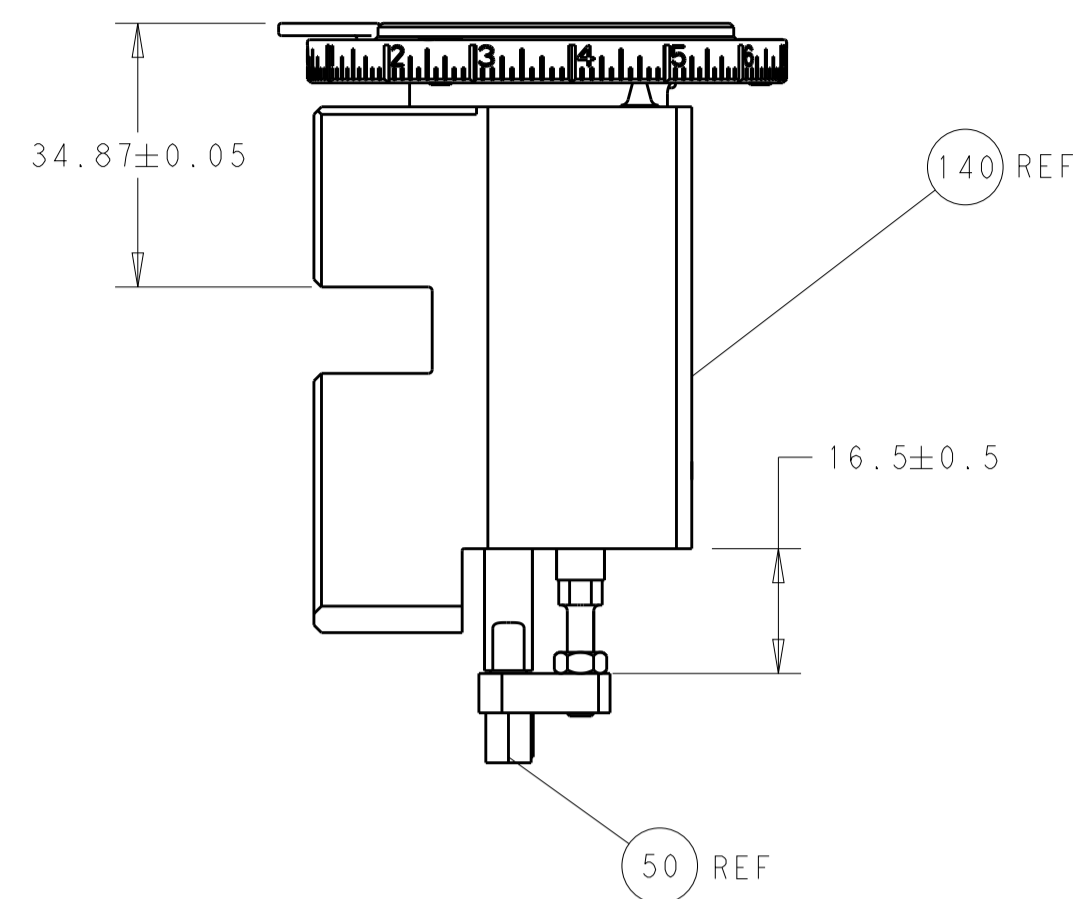

RAM AND HOLDDOWN SET-UP

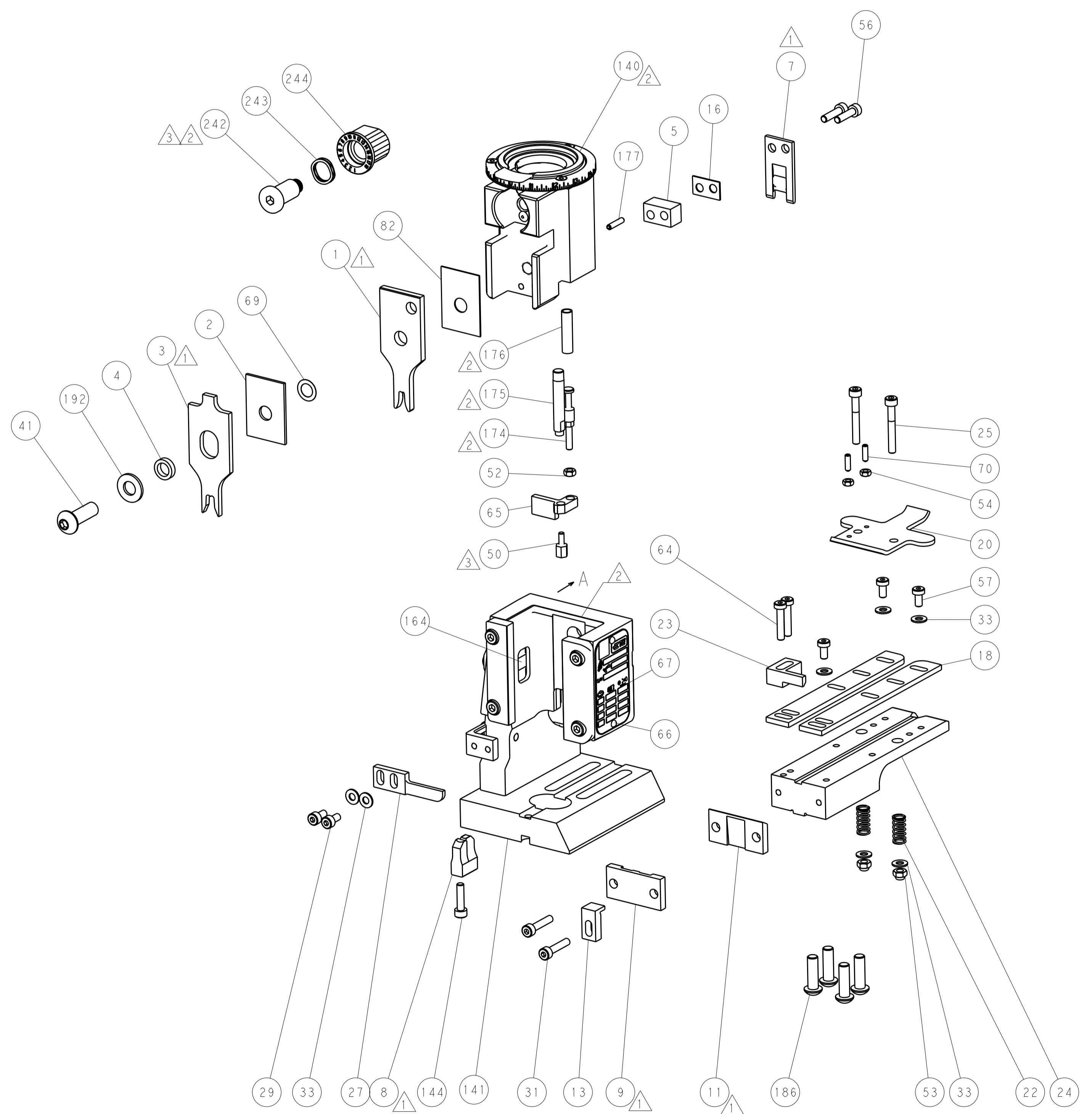

FEED TYPE

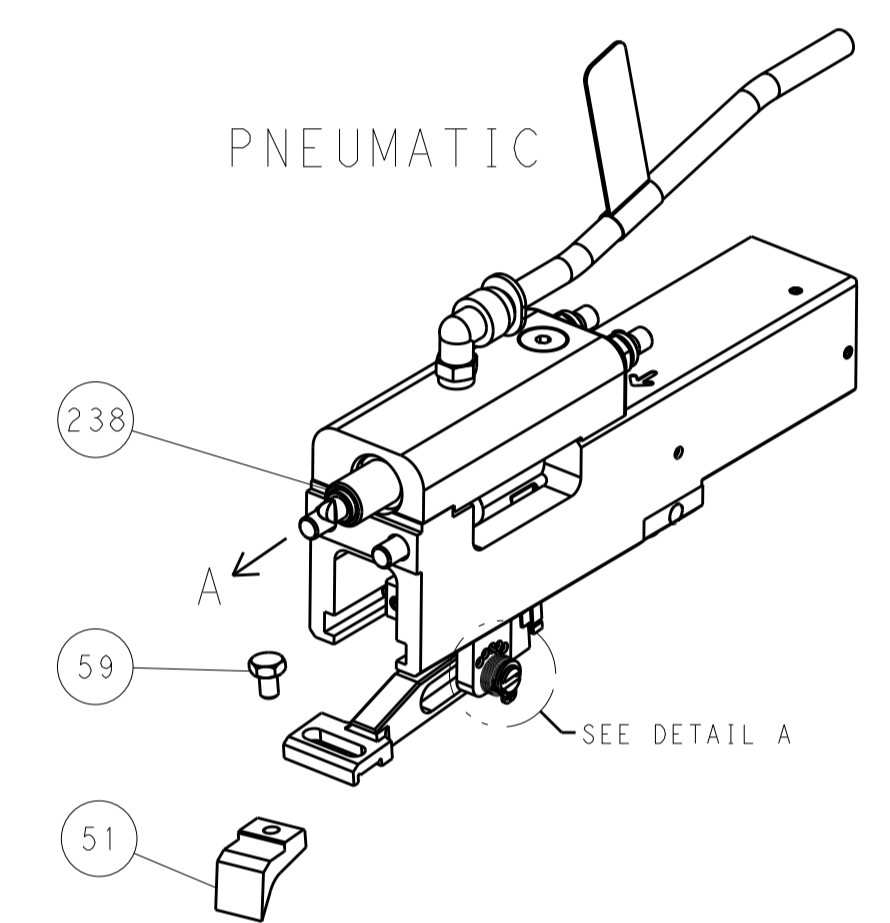

PNEUMATIC

FEED SPRING SETTING POSITION

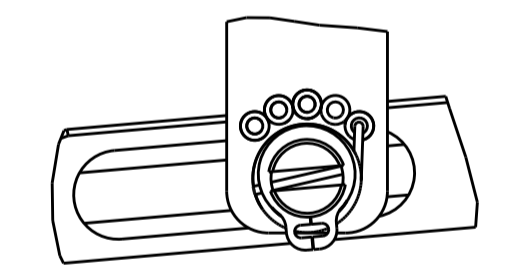

DETAIL A

CAM POSITIONS

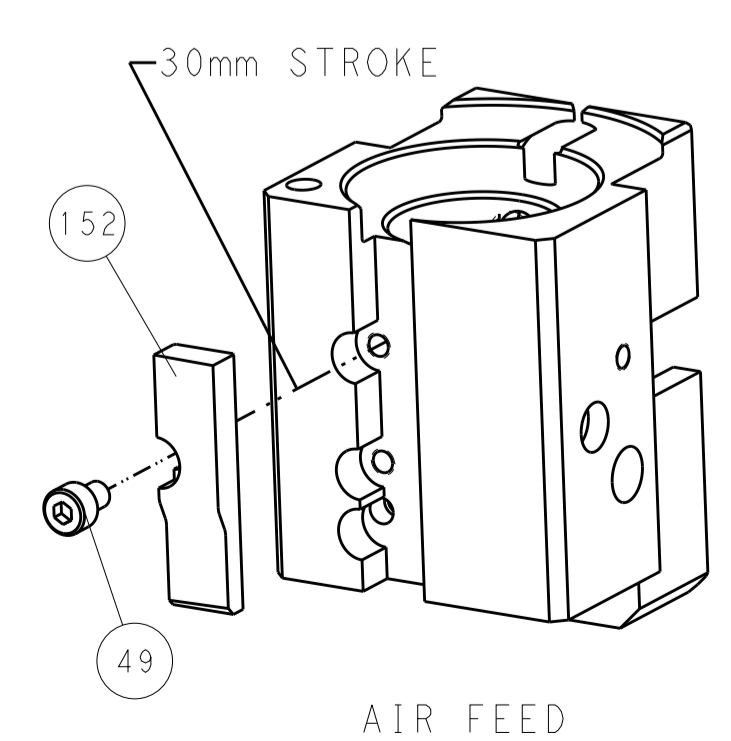

AIR FEED

PACIFIC VERSION
 Shown on sheets 3 of 4 & 4 of 4
 (Atlantic version shown on sheets 1 of 4 & 2 of 4)

DIMENSIONS:		TOLERANCES UNLESS OTHERWISE SPECIFIED:		OWN: R. KNEPPER 02APR2012		STE TE Connectivity	
mm		0 PLC ±		CHK: T. ELBIN 02APR2012		Harrisburg, PA 17105-3608	
MATERIAL:		FINISH:		APVD: M. CLIFFORD 02APR2012		NAME: Ocean End Feed Applicator	
				PRODUCT SPEC:		SIZE: CAGE CODE: DRAWING NO: RESTRICTED TO:	
				APPLICATION SPEC:		A11 00779 C=2150240	
				WEIGHT:		SCALE: 1:1 SHEET 4 OF 4 REV D	
				CUSTOMER ACCESSIBLE PRODUCTION DRAWING			

Mouser Electronics

Authorized Distributor

Click to View Pricing, Inventory, Delivery & Lifecycle Information:

[TE Connectivity:](#)

[7-2150240-7](#)