

PART NUMBER	REV	FIRST USED	POWER UNIT	FEED TYPE	DESCRIPTION
1855631-1	C	122500-1	LEADMAKER	AIR FEED	CUTS CARRIER
1855631-2	C	565435-5	BENCH MODEL K	AIR FEED	CUTS CARRIER
1855631-3	C	354500-1	BENCH MODEL G	AIR FEED	CUTS CARRIER
7-1855631-7	C	-	-	-	SPARE PARTS

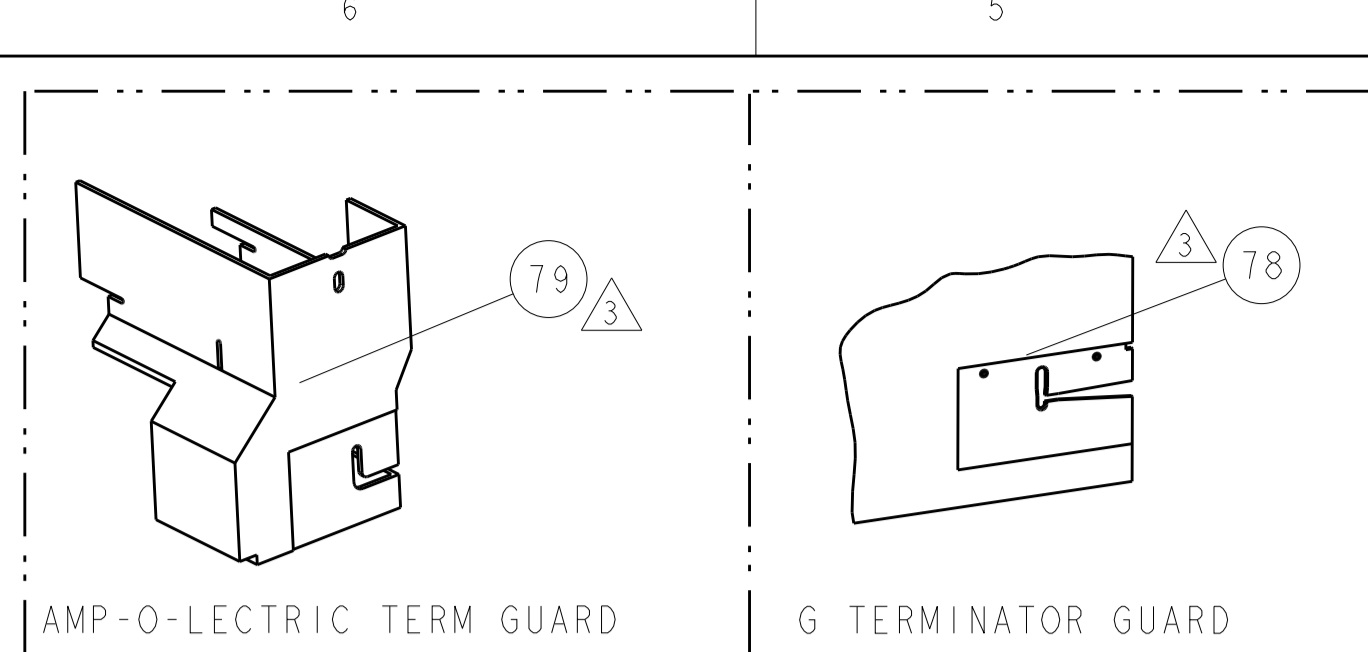

TE PN		TERMINAL APPLICATION SPECIFICATION	TE TERMINAL - TE CRIMP SPECS		REF SETTING
180459	114-20088		CRIMP HEIGHT	WIRE SIZE	B6
180464	114-20088		CRIMP HEIGHT	WIRE SIZE	C2
100645-2	114-19025	.076+ .002/- .002 [1.93mm+ .05/- .05]	CRIMP HEIGHT	WIRE SIZE	C3
100645-3	114-19025	.073+ .002/- .002 [1.85mm+ .05/- .05]	CRIMP HEIGHT	WIRE SIZE	C9
-	-	.071+ .002/- .002 [1.80mm+ .05/- .05]	CRIMP HEIGHT	WIRE SIZE	
-	-	.067+ .002/- .002 [1.70mm+ .05/- .05]	CRIMP HEIGHT	WIRE SIZE	
			CRIMP	SIZE	TYPE
			WIRE	.110 [2.79mm]	F
			INSUL	.180 [4.57mm]	F
			INSUL	Ø .120 - .170	
WIRE STRIP LENGTH		TERM APPL SPEC	FEED	APPLICATOR INSTRUCTIONS	
.173 - .203		SEE ABOVE	.82	408-8040	
				SET UP GAGE	
				458637-1	

LOC	DIST	REV	DATE	BY	APPV
A	66		23JAN2014	XZ	GB

- 1 RECOMMENDED SPARE PARTS
- 2 GREASE LIGHTLY
- 3 GUARD MUST BE IN PLACE WHEN OPERATING APPLICATOR IN A BENCH MACHINE
- 4 INSTALL ITEMS 101, 119 AND 119 ON SIDE OF STRIPPER ON APPLICATOR HOUSING USING ITEM 21.
- 5 FEED TERMINAL OFF OF RECEPTACLE.
- 6 TERMINAL LUBRICANT IS RECOMMENDED.

*** WARNING**
ON INSTALLATION, SET WIRE DISC TO LARGEST WIRE SIZE SETTING. USE OF SETTINGS BELOW MIN. REQUIRED CRIMP HEIGHT SETTING WILL CAUSE DAMAGE TO CRIMP TOOLING.

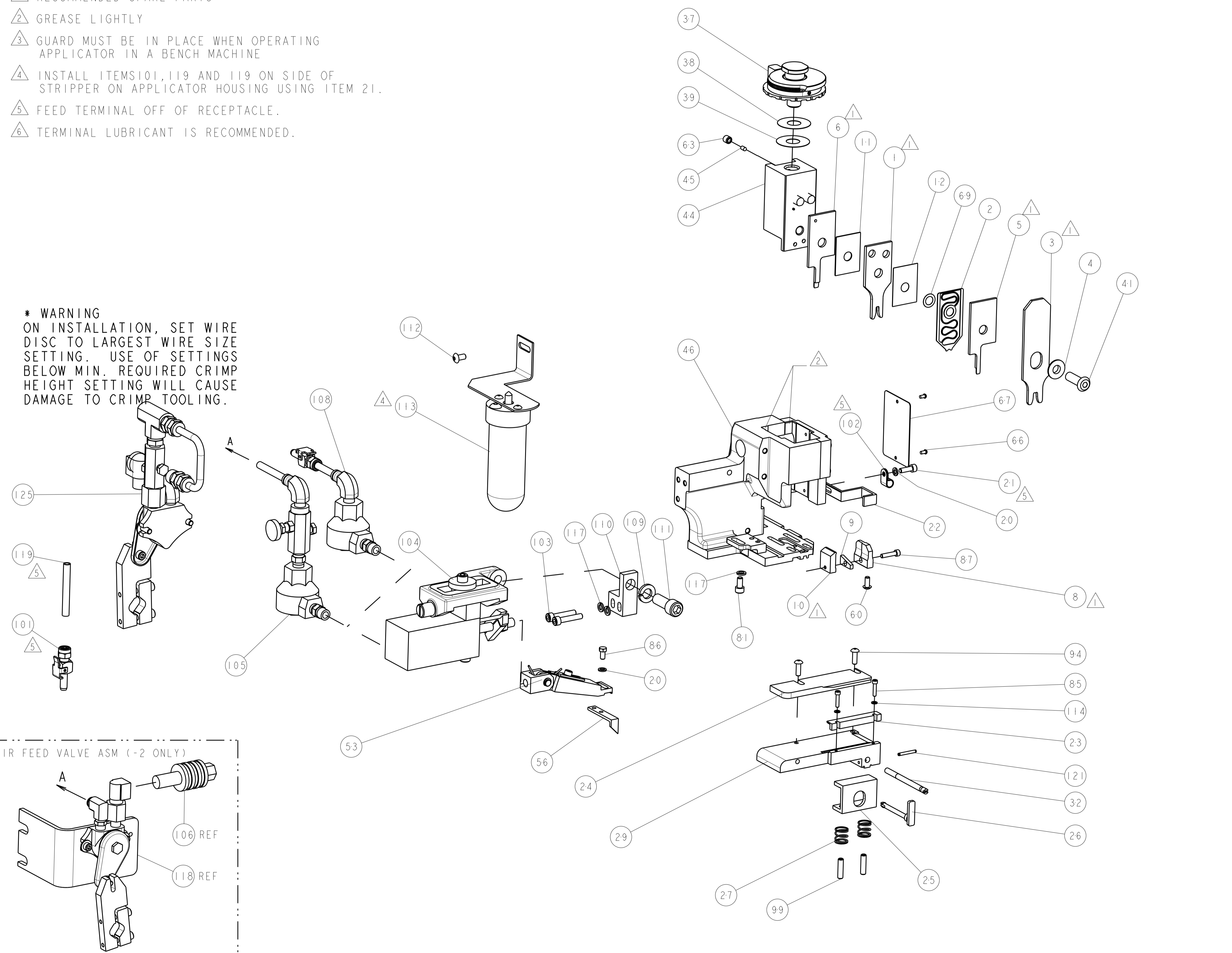

QTY	UNIT	PART NO	DESCRIPTION	ITEM NO
-	-	455350-4	AIR BLAST ASS'Y	125
-	-	4-21028-0	PIN, SLOTTED SPRING .094 X .750	121
-	18 18 18 IN	27319-4	TUBING, POLY-FLO, NATURAL	119
-	-	692655-6	AIR FEED VALVE ASSEMBLY	118
-	3 3 3	21024-5	WASHER, SPRG LOCK, REG NO 10	117
-	REF	455749-1	GUARD WINDOW	116
-	REF	679532-1	INSERT, GUARD	115
-	2 2 2	21024-2	WASHER, SPRG LOCK, REG NO 4	114
-	1 1	1-465184-0	LUBRICATOR ASSY	113
-	1 1	2-21002-6	SCR, BTN SKT HD CAP 10-32 X .375	112
-	1 1 1	3-21001-5	SCR, SKT HD CAP 3/8-16 X 1.000	111
-	1 1 1	459610-1	MOUNT, FEED BRACKET	110
-	1 1 1	21024-8	WASHER, SPRG LOCK, REG 3/8	109
-	1 1	692655-7	AIR FEED VALVE ASSEMBLY	108
-	1	24024-2	VALVE, SHUT OFF	106
-	1	692655-5	AIR FEED VALVE ASSEMBLY	105
-	1 1 1	461065-1	ASSEMBLY, AIR FEED	104
-	2 2 2	3-21000-9	SCR, SKT HD CAP 10-32 X 1.000	103
-	1 1 1	986220-3	CLAMP, CABLE, BLACK	102
-	1	23238-1	INSERT, COUPLING	101
-	2 2 2	5-21006-6	SCR, SET, CUP POINT 10-32 X .750	99
-	2 2 2	2-21002-2	SCR, BTN SKT HD CAP 8-32 X .500	94
-	1 1 1	2-21000-1	SCR, SKT HD CAP 6-32 X .625	87
-	1 1 1	2-22603-0	SCREW, MACH, HEX HD, 8-32 X .312	86
-	2 2 2	1-21000-5	SCR, SKT HD CAP 4-40 X .500	85
-	1 1 1	3-21000-4	SCR, SKT HD CAP 10-32 X .375	81
-	1 1 1	4088040	SF APPL INST 408-8040	72
-	1 1 1	217238-1	GENERAL INSTRUCTION PKG	71
-	1 1 1	2119943-1	WASHER, SPACER	69
-	1 1 1	461264-5	PLATE, IDENTIFICATION	67
-	2 2 2	21017-2	SCREW, DRIVE	66
-	1 1 1	21009-2	SCR, SET, SELF LOCKING 1/4-20 X .250	63
-	1 1 1	22733-8	SCR, BHSC, SELF-LOCKING, 8-32 X .375	60
-	1 1 1	458537-2	PAWL, FEED	56
-	1 1 1	461062-1	FEED FINGER ASSEMBLY	53
-	1 1 1	2-1633399-2	APPL., BASIC AIR FEED SUB ASSY	46
-	1 1 1	690191-1	PLUG, NYLON	45
-	1 1 1	2-455673-1	RAM, SIDE FEED	44
-	1 1 1	690686-3	CRIMPER, BOLT SPECIAL	41
-	1 1 1	690125-1	SHIM SUB-ASSY	39
-	1 1 1	469367-1	SHIM	38
-	1 1 1	879103-2	FINE ADJUST HEAD ASSEMBLY	37
-	1 1 1	690432-3	ADJUSTMENT SCREW	32
-	1 1 1	455671-1	PLATE, STRIP GUIDE	29
-	2 2 2	22284-1	SPRING, COMPRESSION	27
-	1 1 1	690546-1	LEVER, DRAG RELEASE	26
-	1 1 1	690792-3	DRAG, STOCK	25
-	1 1 1	1-690440-8	GUIDE, REAR STRIP	24
-	1 1 1	690712-2	FRONT STRIP GUIDE	23
-	1 1 1	1-458230-1	STRIPPER	22
-	1 1 1	2-21000-7	SCR, SKT HD CAP 8-32 X .500	21
-	2 2 2	21024-4	WASHER, SPRG LOCK, REG NO 8	20
-	1 1 1	455888-1	SPACER, CRIMPER	12
-	1 1 1	455888-6	SPACER, CRIMPER	11
-	1 1 1	690787-1	SHEAR PLATE	10
-	1 1 1	690790-1	BLOCK, SHEAR SPACER	9
-	1 1 1	454639-6	ANVIL, SPECIAL	8
-	-	-	-	7
-	1 1 1	3-853720-1	BLADE, SLUG	6
-	1 1 1	1-853721-3	BLADE, SLUG	5
-	1 1 1	238009-4	BLOCK, FL CRIMPER SPACER	4
-	1 1 1	9-456134-7	CRIMPER, INSULATION F PREMIUM	3
-	1 1 1	2119791-9	DEPRESSOR, WIRE	2
-	1 1 1	4-456408-0	CRIMPER, WIRE PREMIUM	1

THIS DRAWING IS A CONTROLLED DOCUMENT.

APPROVED: G. BAILEY, 24 MARCH 2011

TE Connectivity

FINE ADJUST SIDE FEED HDM APPLICATOR

Customer Accessible Production Drawing

Mouser Electronics

Authorized Distributor

Click to View Pricing, Inventory, Delivery & Lifecycle Information:

[TE Connectivity:](#)

[1855631-2](#)