

SECTION A-A
SCALE 10:1

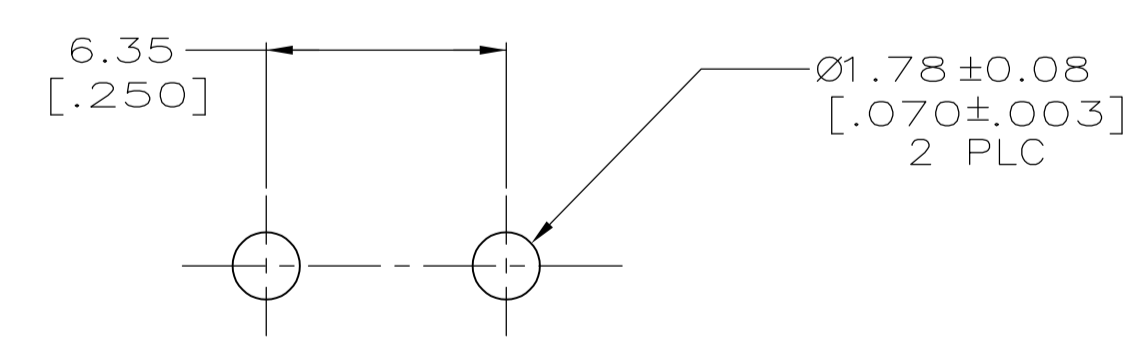

RECOMMENDED MOUNTING HOLE PATTERN
FOR 1.57 [.062] THICK P.C. BOARD

- 1 PARTS COMPLY TO AMP SOLDERABILITY SPECIFICATION 109-11-3.
- 3 CONTACT IS PLATED OVERALL WITH 0.00127 [.000050] NICKEL, THEN 0.00076 [.000030] GOLD OVER CONTACT LENGTH INDICATED AND MATTE TIN-LEAD ON SOLDER TAIL END.
- 4 CIRCUIT IDENTIFICATION CHARACTERS ARE ADJACENT TO THE INDICATED CAVITIES, BUT LOCATION AND ORIENTATION MAY DIFFER FROM PRINT.
- 5 DIMENSIONS IN BRACKETS ARE IN INCHES.
- 6 CONTACT IS PLATED OVERALL WITH 0.00127 [.000050] NICKEL, THEN 0.00076 [.000030] GOLD OVER CONTACT LENGTH INDICATED AND MATTE TIN ON SOLDER TAIL END.
- 7 SUPERSEDED BY 350428-4

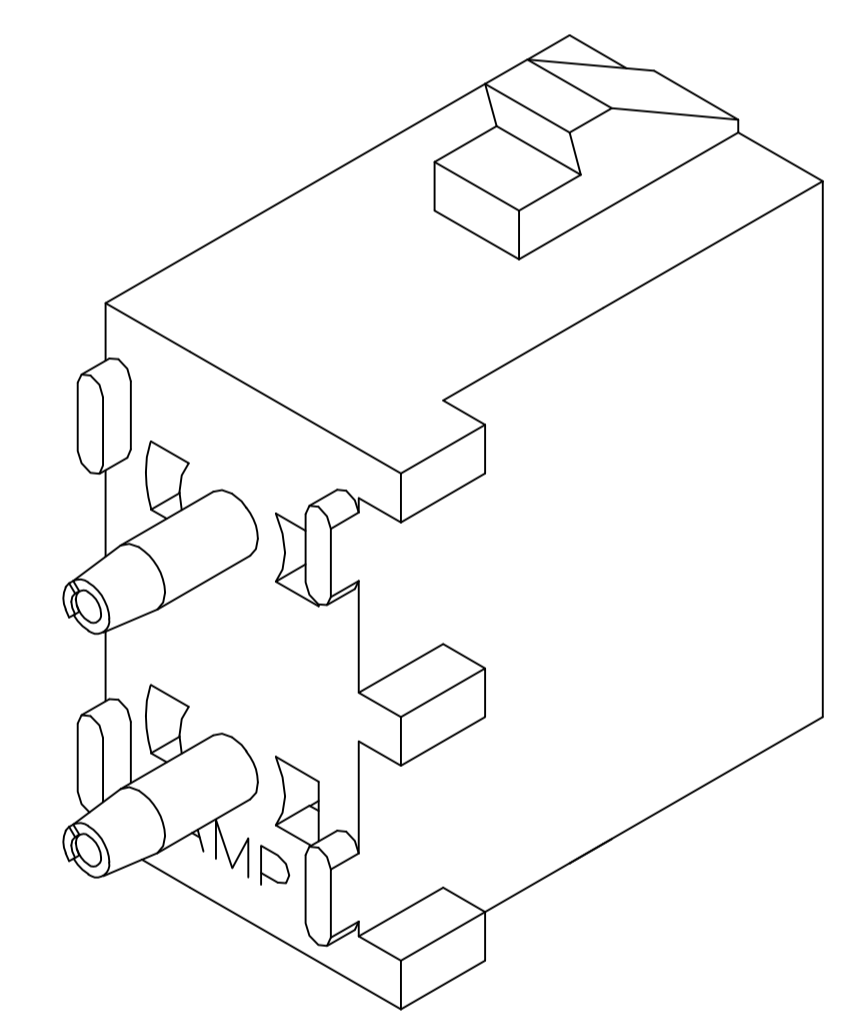

PHOSPHOR BRONZE, GOLD 6	NYLON, UL94V-2 NATURAL	350428-4
PHOSPHOR BRONZE, GOLD 3	NYLON, UL94V-2 NATURAL	350428-2
PHOSPHOR BRONZE, PRE-TIN	NYLON, UL94V-2 NATURAL	350428-1
PIN CONTACT MATERIAL AND FINISH	HOUSING MATERIAL	PART NUMBER

THIS DRAWING IS A CONTROLLED DOCUMENT.		DIN S. CARPENTER 24JUN2003		TE Connectivity	
DIMENSIONS: mm		CHK S. RIDGILL 24JUN2003			
TOLERANCES UNLESS OTHERWISE SPECIFIED:		APVD S. RIDGILL 24JUN2003		NAME	
0 PLC ±		PRODUCT SPEC		PIN HEADER ASSEMBLY, 2 CIRCUIT	
1 PLC ±		APPLICATION SPEC		SIZE	
2 PLC ± 0.13 [.005]		WEIGHT		CAGE CODE	
3 PLC ±		CUSTOMER DRAWING		DRAWING NO.	
4 PLC ±		SCALE 5:1		SHEET 1 OF 1	
ANGLES ± 0°30'		REV Y2		REV	

Mouser Electronics

Authorized Distributor

Click to View Pricing, Inventory, Delivery & Lifecycle Information:

[TE Connectivity:](#)

[350428-1](#)