

LOC	DIST	P	F	ZONE	LTR	REVISIONS	DATE	APPD
CM	52				L	REV & REDWN PER EC 0730-0072-94	6-25-93	K5

- REQUIRES A #6 PAN HEAD TYPE "B" SELF TAPPING PAN HEAD SCREW, 9.53 [.375] LONG.
- DIMENSIONS IN BRACKETS ARE IN INCHES.

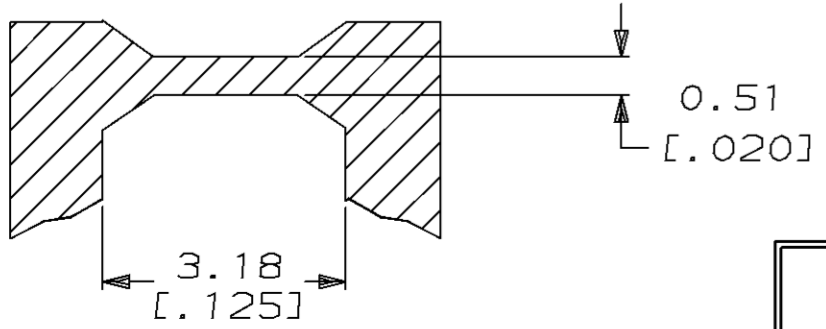
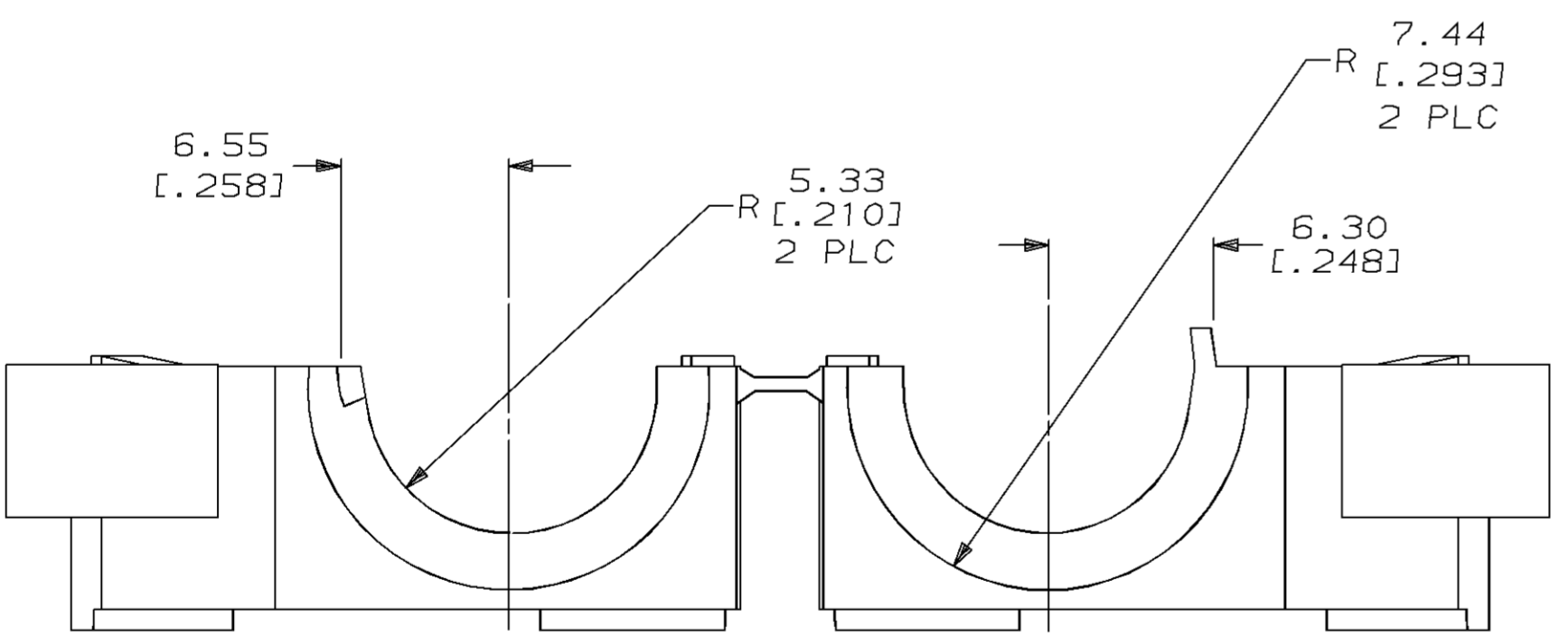
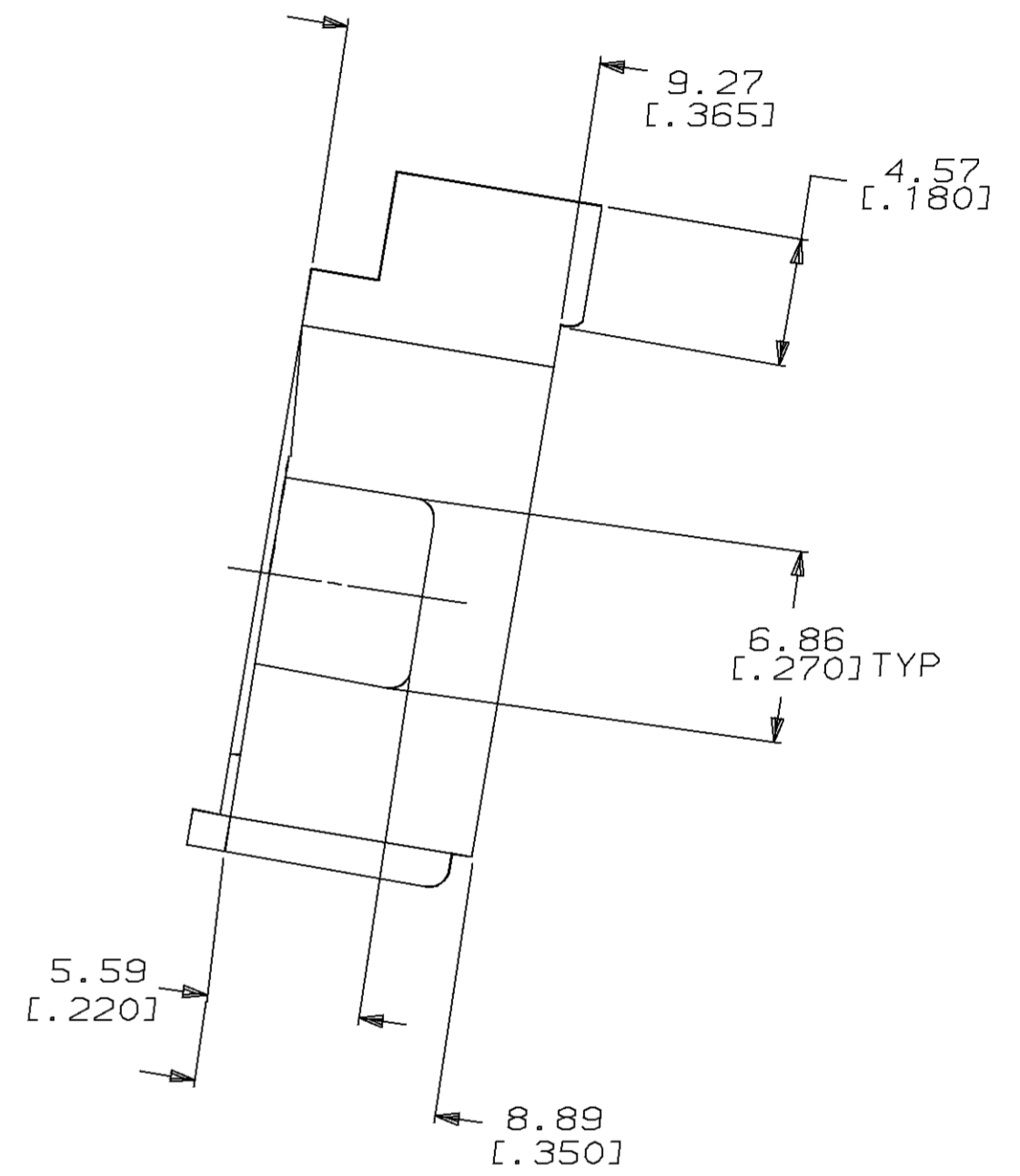
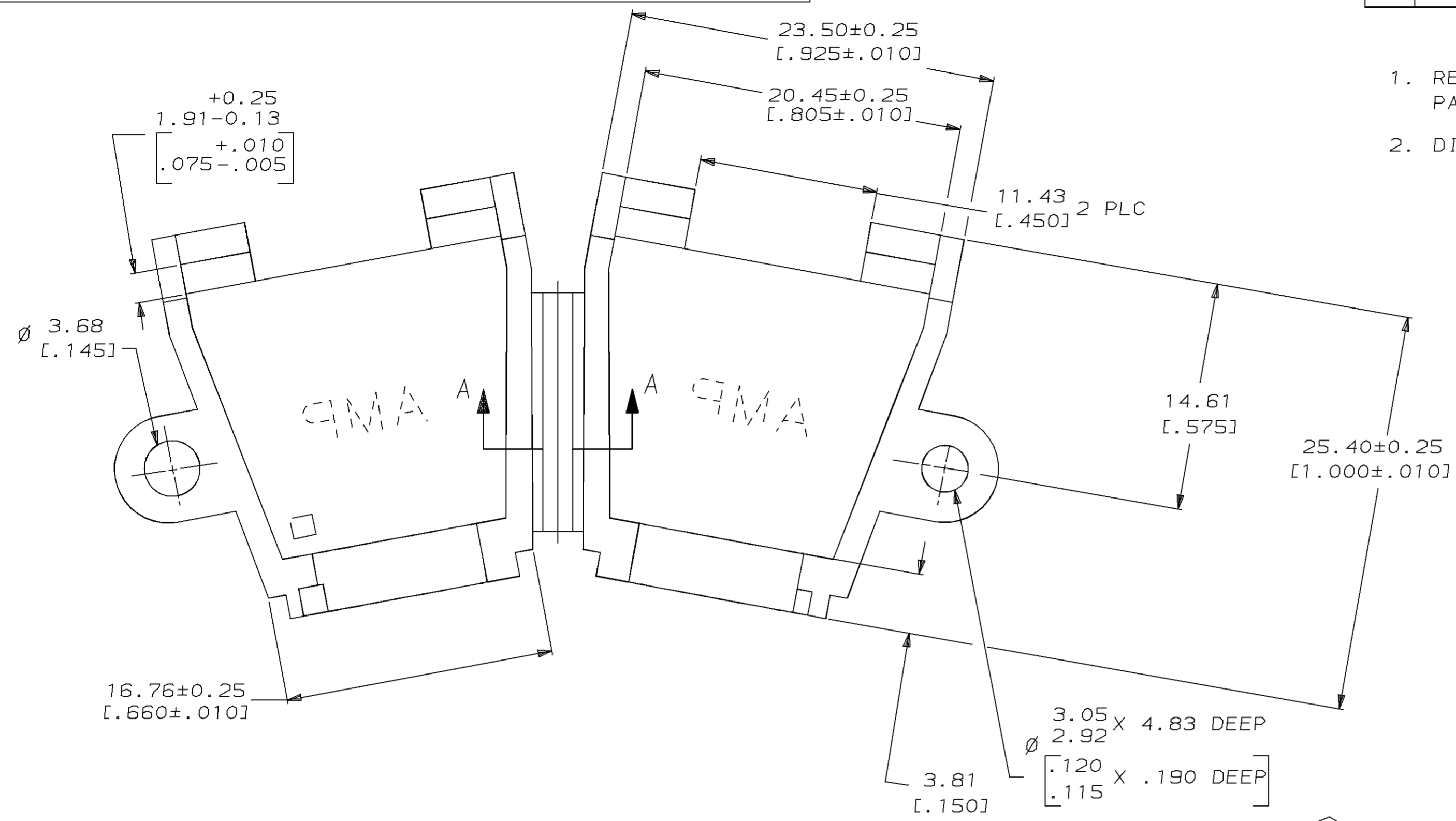

**METRIC**

THIS DRAWING IS A CONTROLLED DOCUMENT FOR AMP INCORPORATED. IT IS SUBJECT TO CHANGE AND THE CONTROLLING ENGINEERING ORGANIZATION SHOULD BE CONTACTED FOR THE LATEST REVISION.

DO NOT SCALE PRINT. UNLESS SPECIFIED DIMENSIONS IN mm [INCHES] TOLERANCES ON: 2 PLC DEC ± 0.13 [.005] 3 PLC DEC ± - ANGLES ± -	DR 6-28-93 K. SALMON CHK 6-28-93 R. SWING APPD - W. LONG APPD - W. LONG PRODUCT SPEC -	<b>AMP</b> AMP Incorporated Harrisburg, PA 17105-3608	
MATERIAL NYLON	FINISH COLOR, SEE TABLE	NAME STRAIN RELIEF, HINGED, 12 POSITION	
	APPLICATION SPEC -	SIZE C	CAGE CODE 00779
	WEIGHT -	DRAWING NO G=350374	
		SCALE 4:1	SHEET 1 OF 1

COLOR	PART NO
BLACK	1-350374-9
BRICK RED	350374-1

# Mouser Electronics

Authorized Distributor

Click to View Pricing, Inventory, Delivery & Lifecycle Information:

[TE Connectivity:](#)

[350374-1](#)