

THIS DRAWING IS UNPUBLISHED. RELEASED FOR PUBLICATION
 © COPYRIGHT - By - ALL RIGHTS RESERVED.

P	LTR	DESCRIPTION	DATE	DWN	APVD
G3		REVISED PER ECO-12-003796	28FEB12	KH	DR
G4		REVISED PER ECO-17-008806	20FEB2018	RS	DR

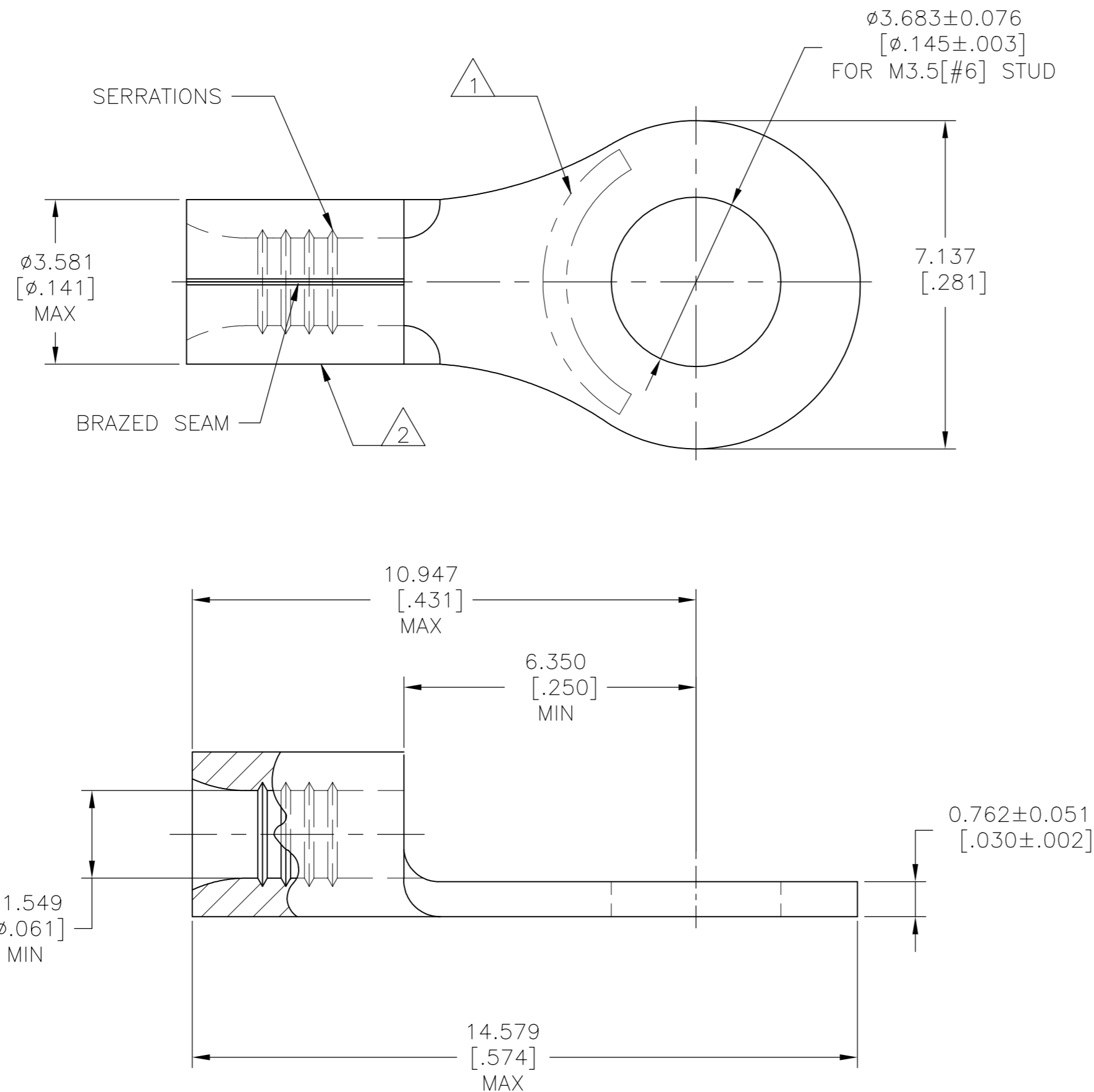

AMP
WIRE RANGE

22-16 AWG
SOLID OR STRANDED

- 1 STAMP AMP 22-18 APPROX AS SHOWN 22-16 TERMINALS ARE STAMPED 22-18 IN ACCORDANCE WITH MILITARY SPECIFICATION SAE AS7928; COMMERCIAL WIRE RANGE IS 22-16
- 2 WIRE BARREL COLOR CODED ORANGE TO DENOTE NICKEL MATERIAL
- 3 NOTE DELETED
- 4 GOLD PLATE 0.00127[.000050] MIN EXT THK, PER ASTM B488, TYPE1, CODE C OVER NICKEL FLASH SAE AMS QQ-N-290, OVER WOODS NICKEL FLASH PER ASTM B558.

AMP INCORPORATED		MAX RECOMMENDED OPERATING TEMPERATURE:
CUSTOMER SERVICE SYSTEMS		SEE TABLE
FOR ADDITIONAL PRODUCT INFORMATION OR COPIES OF DRAWINGS AND TECHNICAL DOCUMENTS	PRODUCT INFORMATION CENTER 1-800-522-6752	VOLTAGE RATING: NOT APPLICABLE
FOR APPLICATION TOOLING INFORMATION	TOOLING ASSISTANCE CENTER 1-800-722-1111	WIRE CROSS SECTIONAL AREA RANGE: 0.26-1.65mm ² [509-3,260] CIR MILS SOLID OR STRANDED
FOR ORDER ENTRY	1-800-526-5142	

FINISH	MAX OPERATING TEMPERATURE	QUANTITY	PACKAGING TYPE	PART NO
4	260°C [500°F]	1000	LOOSE PIECE	321889-1
-	649°C [1200°F]	1000	LOOSE PIECE	2-321889-1
-		5000	ON TAPE	2-321889-3
2	-	1000	LOOSE PIECE	321889

THIS DRAWING IS A CONTROLLED DOCUMENT.		DWN TA BRINKMAN 4-15-93	STE TE Connectivity Ltd.	
DIMENSIONS: mm [INCHES]		CHK DA PATTERSON 4-15-93	NAME	
TOLERANCES UNLESS OTHERWISE SPECIFIED:		APVD DE MILLER 4-15-93	PRODUCT SPEC	
0 PLC ± - 1 PLC ± - 2 PLC ± - 3 PLC ± 0.127[.005] 4 PLC ± -		APPLICATION SPEC		TERMINAL, RING TONGUE, HIGH TEMPERATURE, STRATO-THERM™ 22-16 AWG
MATERIAL NICKEL PER ASTM B-152 ANNEALED	FINISH SEE TABLE	WEIGHT	SIZE A2	CAGE CODE 00779
CUSTOMER DRAWING		DRAWING NO 321889	RESTRICTED TO	SCALE 10:1
		SHEET 1 of 1	REV G4	

Mouser Electronics

Authorized Distributor

Click to View Pricing, Inventory, Delivery & Lifecycle Information:

[TE Connectivity:](#)

[2-321889-3](#)