

REVISIONS				
P	LTN	DESCRIPTION	DATE	APPD
A		RELEASED PER ECO-17-004604	02MAR2017	CP GL
B		RELEASED PER ECO-18-007459	24APR2018	FZ CP

CABLE PINOUT			
PAIR	PIN NAME	P1	P2
GROUND BUS	-	1	1
1	HF10_RX_DN(1)	2	2
	HF10_RX_DP(1)	3	3
GROUND BUS	-	4	4
GROUND BUS	-	28	4
2	HF10_RX_DN(2)	27	5
	HF10_RX_DP(2)	26	6
GROUND BUS	-	25	7
3	HF10_RX_DN(3)	5	8
	HF10_RX_DP(3)	6	9
GROUND BUS	-	25	10
4	HF10_RX_DN(4)	24	11
	HF10_RX_DP(4)	23	12
GROUND BUS	-	22	13
GROUND BUS	-	7	14
GROUND BUS	-	8	15
5	HF10_TX_DP(4)	9	16
	HF10_TX_DN(4)	10	17
GROUND BUS	-	21	18
6	HF10_TX_DP(3)	20	19
	HF10_TX_DN(3)	19	20
GROUND BUS	-	11	21
7	HF10_TX_DP(2)	12	22
	HF10_TX_DN(2)	13	23
GROUND BUS	-	14	24
GROUND BUS	-	18	24
8	HF10_TX_DP(1)	17	25
	HF10_TX_DN(1)	16	26
GROUND BUS	-	15	27

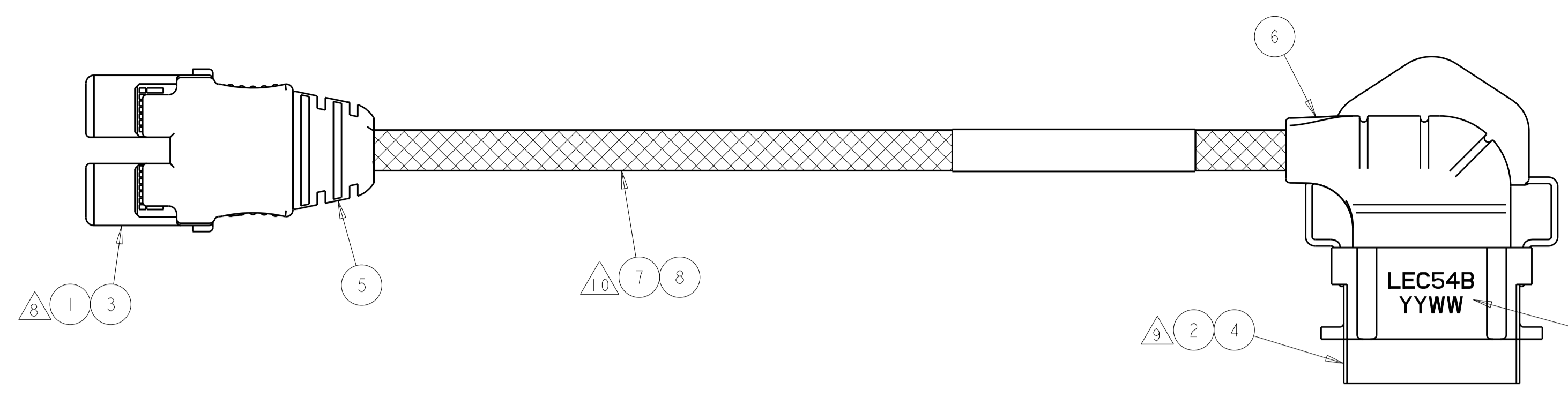

CONNECTOR MARKED WITH CONNECTOR TYPE AND DATE CODE

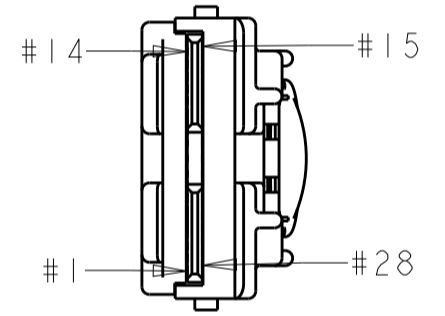
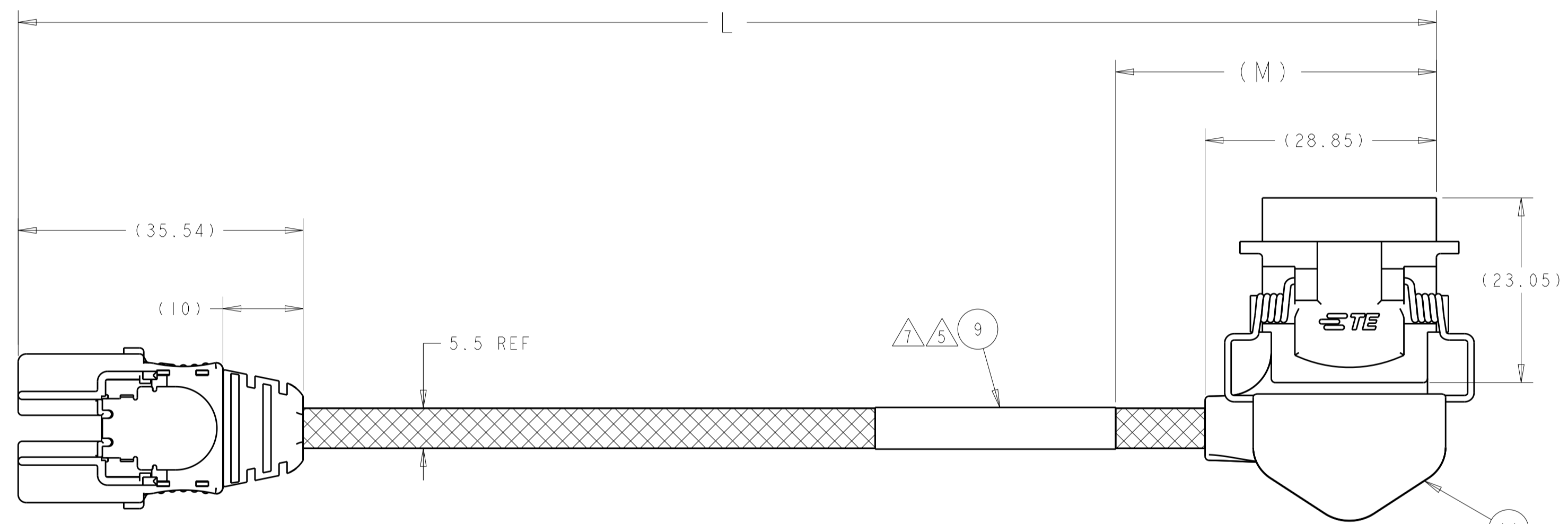
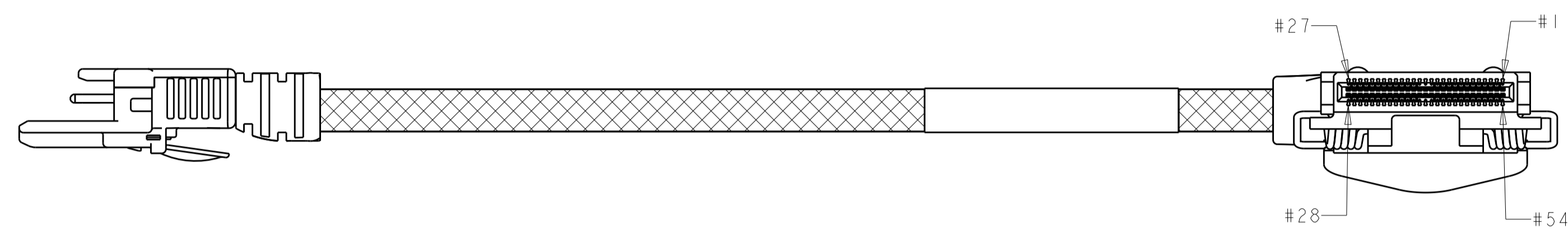

P1

P2

2821723-1, -2, -3, -5, -6

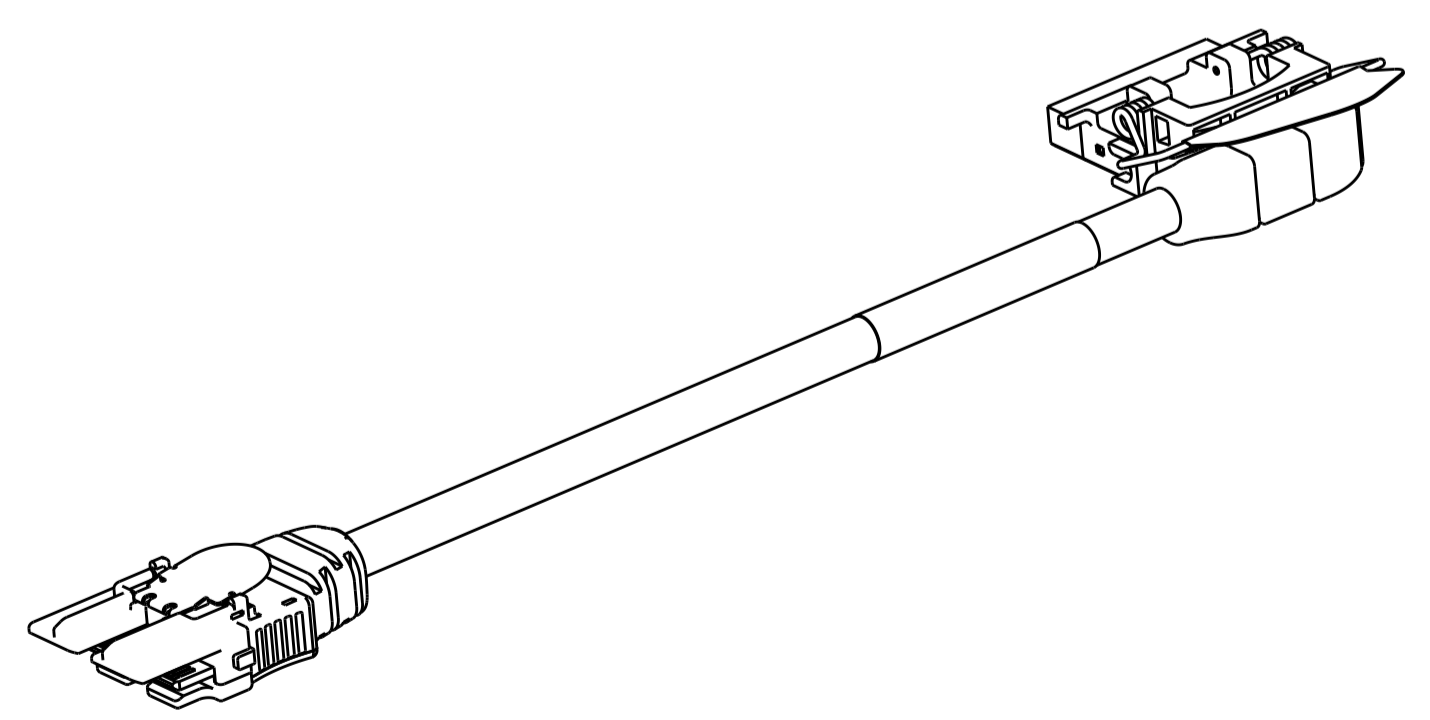

△ WRAP (SHEET 1)	60	600±5	-	2821723-6	△12
△ WRAP (SHEET 1)	60	460±5	-	2821723-5	△12
△ FLAG (SHEET 2)	60	142±5	-	2821723-4	
△ WRAP (SHEET 1)	40	515±5	H95969-005	2821723-3	△12
△ WRAP (SHEET 1)	100	371±5	H68075-005	2821723-2	
△ WRAP (SHEET 1)	40	335±5	H95968-005	2821723-1	
LABEL TYPE	(M)	L	INTEL PART NO	TE PART NO	

1	1	1	1	1	1	PULL TAB	11
-	-	1	-	-	-	LABEL, FLAG	10
1	1	-	1	1	1	LABEL, WRAP	9
AR	AR	AR	AR	AR	AR	SLEEVING, EXPANDABLE	8
AR	AR	AR	AR	AR	AR	85 OHM TWINAX CABLE, 30AWG 25G TURBO TWIN™ △10	7
1	1	1	1	1	1	OVERMOLDED STRAIN RELIEF, LECB	6
1	1	1	1	1	1	OVERMOLDED STRAIN RELIEF, IFP	5
1	1	1	1	1	1	DUST COVER, LECB (NOT SHOWN)	4
1	1	1	1	1	1	DUST COVER, IFP (NOT SHOWN)	3
1	1	1	1	1	1	LEC 54B RECPT, 54 POSN	2
1	1	1	1	1	1	IFP PLUG, 28 POSN	1
-6	-5	-4	-3	-2	-1	DESCRIPTION	ITEM NO

THIS DRAWING IS A CONTROLLED DOCUMENT. DWG: T. SMITH 17JUL2016
 CHK: C. POGASH 17JUL2016

DIMENSIONS: mm
 TOLERANCES UNLESS OTHERWISE SPECIFIED:
 0 PLC ±0.5
 1 PLC ±0.5
 2 PLC ±0.13
 3 PLC ±0.013
 4 PLC ±0.013
 ANGLES ±0.5°
 FINISH

MATERIAL: -
 FINISH: -

APVD: -
 PRODUCT SPEC: -
 APPLICATION SPEC: -
 WEIGHT: -
 CUSTOMER DRAWING

NAME: IFP ASSEMBLY, TYPE B, LEFT EXIT 1-PORT, NON-INVERTED.
 SIZE: A1
 CAGE CODE: -
 DRAWING NO: 2821723
 SCALE: 2:1
 SHEET 1 OF 2
 REV B

STE TE Connectivity

REVISIONS				
P.	LTN	DESCRIPTION	DATE	OWN APVD
		SEE SHEET 1		

1. THIS ASSEMBLY CONFORMS TO INTEL PART NO. (SEE TABLE).
2. EACH ASSEMBLY TESTED FOR OPENS, SHORTS AND SIGNAL INTEGRITY.
3. ALL MATERIALS, COMPONENTS, AND PROCESSES SHALL COMPLY WITH TEC-138-702 AND CONTAIN NO BANNED OR RESTRICTED SUBSTANCES.
4. EACH ASSEMBLY PACKAGED IN ESD MOISTURE BARRIER BAG WITH DESICCANT.

5 LABEL INFORMATION (ITEM 9): 2821723-1, -2, -3

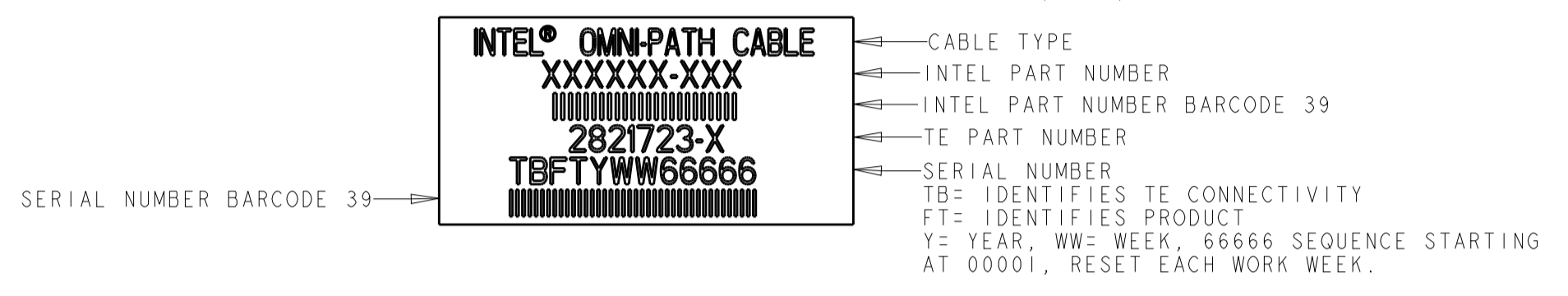

6 LABEL INFORMATION (ITEM 10): 2821723-4

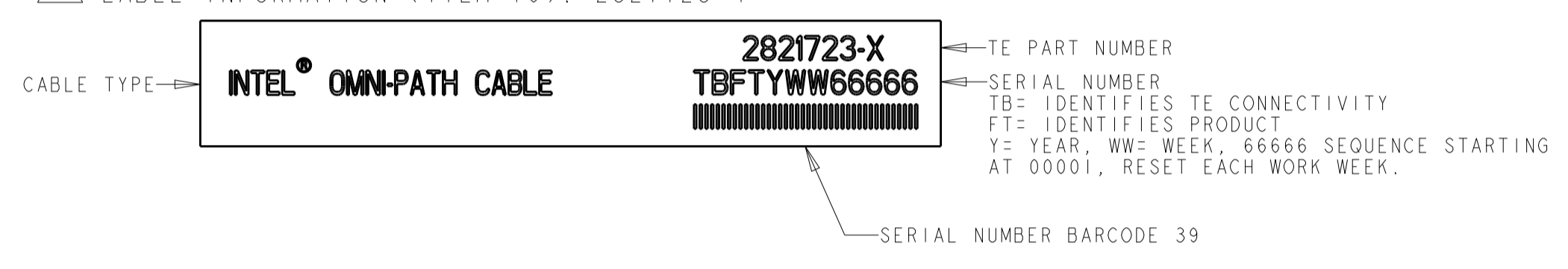

7 LABEL INFORMATION (ITEM 9): 2821723-5, -6

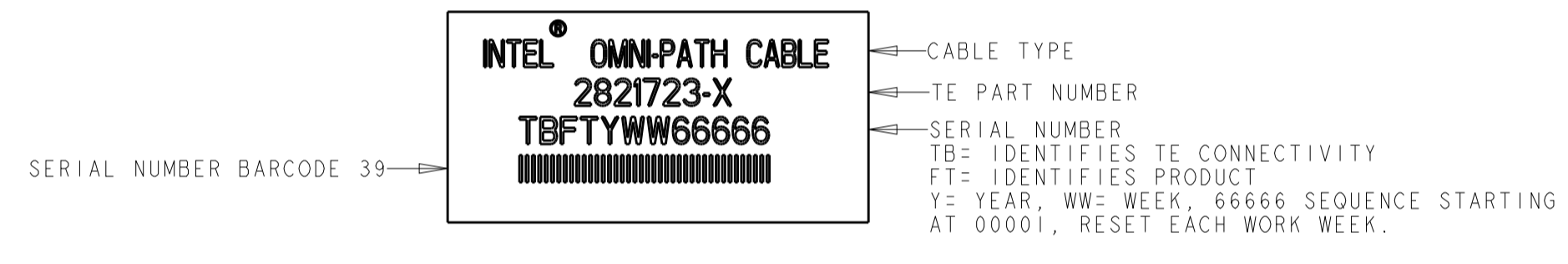

8 FINISH (CONTACT PADS): 30µIN MINIMUM GOLD PER TE SPEC 112-162-1 OVER 100µIN MINIMUM NICKEL PER TE SPEC 112-25-2.

9 FINISH: 50µIN MINIMUM GOLD PER TE SPEC 112-162-5, IN LOCALIZED GOLD PLATE AREA, OVER 50µIN MINIMUM NICKEL PER TE SPEC 112-25-2 ON ENTIRE STOCK.

10 CABLE PART #: 023B2LF023
 CABLE SPEC: 104-1587

11. CABLE ASSEMBLY BUILT IN ACCORDANCE WITH INTEL DESIGN GUIDE 1.0

12 CABLE ASSEMBLY LENGTH OFFERED BY TE IS NOT REFERENCED WITHIN INTEL DESIGN GUIDE 1.0

13. NO REACH SVHC SHALL BE CONTAINED ABOVE THE THRESHOLD AS DEFINED IN THE REACH SVHC COMPLIANCE DEFINITION WITHIN ANNEX A OF TEC-138-702.

14. ALL PRODUCT COMPONENTS AND PROCESSES SHALL MEET THE HALOGEN REQUIREMENTS OF CODE 2: Br<900ppm, Cl<900ppm, Br+Cl<1500ppm PER HOMOGENOUS MATERIAL.

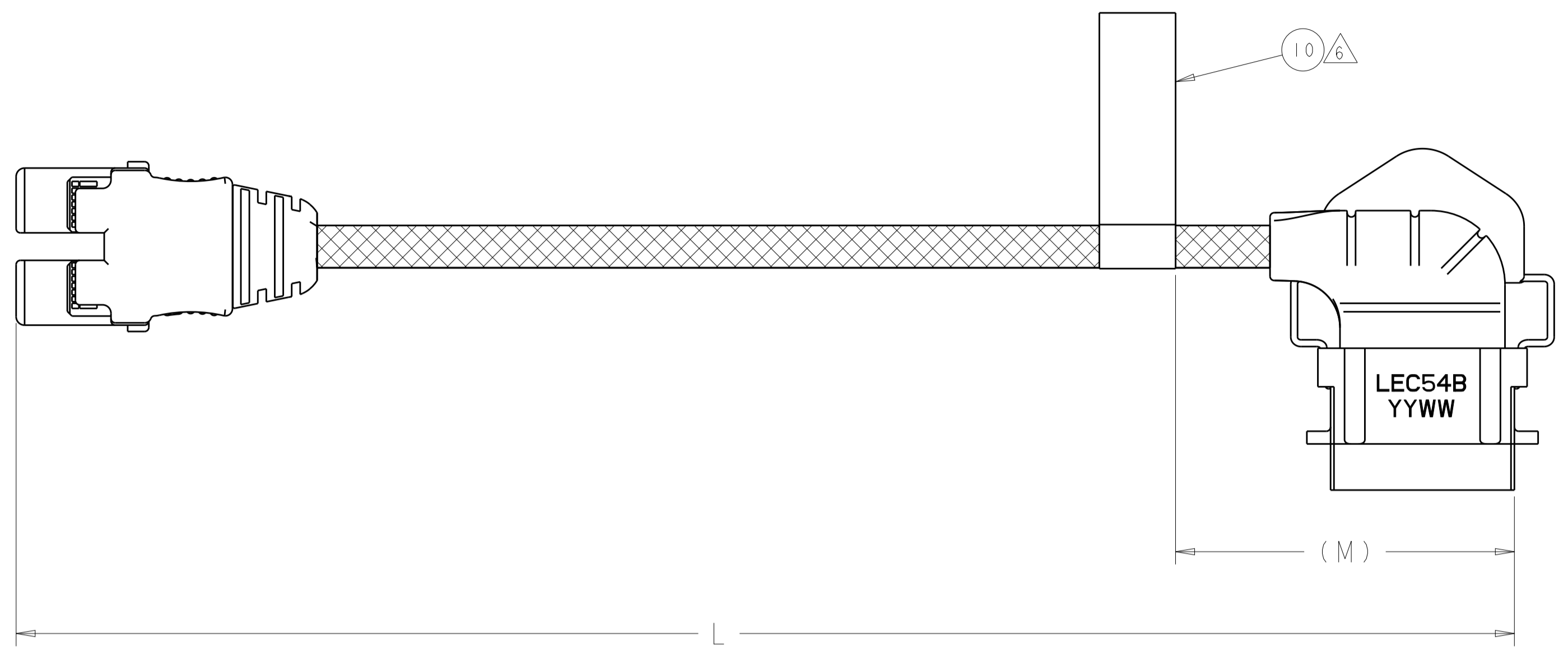

**2821723-4
 FLAG LABEL
 REQUIREMENT
 ALL ASSEMBLY REQUIREMENTS
 SAME AS -1 EXCEPT FOR
 LABEL**

THIS DRAWING IS A CONTROLLED DOCUMENT.		OWN T. SMITH 17 JUL 2016	TE Connectivity	
DIMENSIONS:		CHK C. POGASH 17 JUL 2016	NAME IFP ASSEMBLY, TYPE B, LEFT EXIT 1-PORT, NON-INVERTED.	
mm	TOLERANCES UNLESS OTHERWISE SPECIFIED:	APVD	PRODUCT SPEC	RESTRICTED TO
	0 PLC ±		APPLICATION SPEC	
	1 PLC ±0.5		WEIGHT	
	2 PLC ±0.13		CUSTOMER DRAWING	
	3 PLC ±0.013		SCALE 2:1	SHEET 2 OF 2
	4 PLC ±		REV B	
	ANGLES ±			
MATERIAL	FINISH			

Mouser Electronics

Authorized Distributor

Click to View Pricing, Inventory, Delivery & Lifecycle Information:

[TE Connectivity:](#)

[2821723-3](#)