

REVISIONS					
P.	LTN	DESCRIPTION	DATE	DWN	APVD
A		RELEASED PER ECO-19-013357	29AUG2019	CJV	JW
B		REVISED PER ECO-19-014774	26SEP2019	CJV	JW

PICK AND PLACE TAPE SHOWN AS TRANSPARENT FOR CLARITY

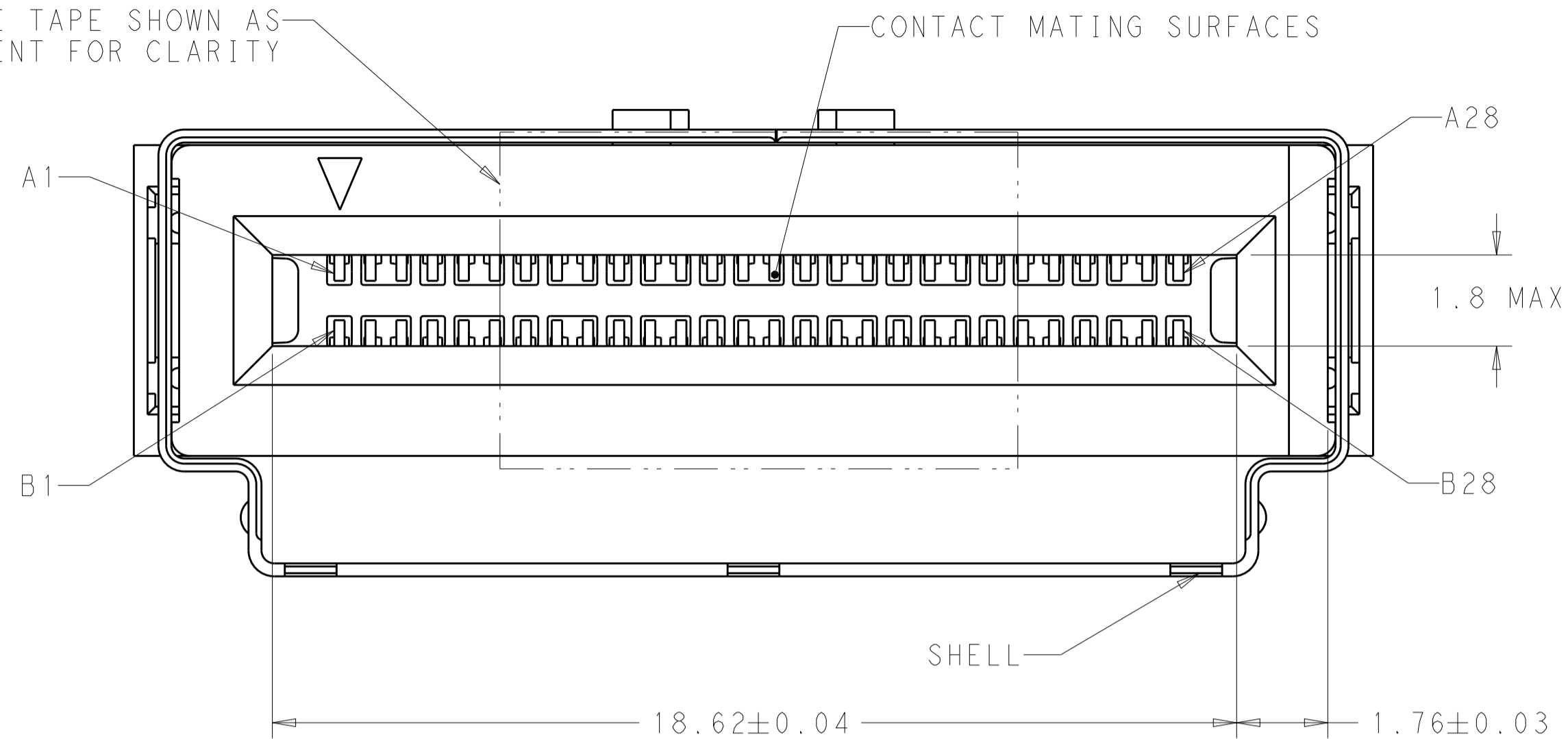

- 1 HOUSING - LCP, UL94V-0, BLACK. CONTACT OVERMOLDS - LCP, UL94V-0, BLACK. SHELL, CONTACTS, HOLD DOWNS - COPPER ALLOY. PICK AND PLACE TAPE - POLYIMIDE FILM.
- 2 CONTACTS - GOLD PLATE ON MATING SURFACES, TIN PLATE ON SOLDER FEET. HOLD DOWNS - TIN PLATE. SHELL - NICKEL PLATE, TIN PLATE ON HOLD DOWNS.
- 3 DATUMS AND BASIC DIMENSIONS ESTABLISHED BY CUSTOMER.
- 4. MINIMUM HOST PCB THICKNESS: 1.5.
- 5 SEE MSA SPECIFICATION FOR ADDITIONAL PADDLE CARD LAYOUTS COMPATIBLE WITH THIS RECEPTACLE AND FOR OPTIONAL SPLIT CONTACT PAD LAYOUTS FOR THE PADDLE CARD. SPECIFICATION PINOUT MAY ALSO DESIGNATE PAD SEQUENCE DIFFERENT FROM ILLUSTRATION.

- 6 POSITIONS DESIGNATED AS "SIGNAL" ARE REQUIRED LOCATIONS FOR HIGH SPEED DIFFERENTIAL PAIR SIGNALING. THESE LOCATIONS MAY ALSO BE USED FOR SUPPORTING SIDEBAND SIGNALS OR OTHER UTILITY PURPOSES. POSITIONS DESIGNATED AS "GROUND" ARE REQUIRED WHEN SUPPORTING HIGH SPEED DIFFERENTIAL SIGNALS. THESE LOCATIONS MAY ALSO BE USED FOR SIDEBAND SIGNALS OR OTHER UTILITY PURPOSES.
- 7 RECOMMENDED COMPONENT AND TRACE KEEP OUT AREA. EACH EDGE 0.15 MIN FROM EDGE OF HOLE.
- 8 TAPE AND REEL PACKAGED FOR PICK AND PLACE SMT PROCESSING, SEE FIGURE 1. POCKET TAPE: WIDTH = 44.

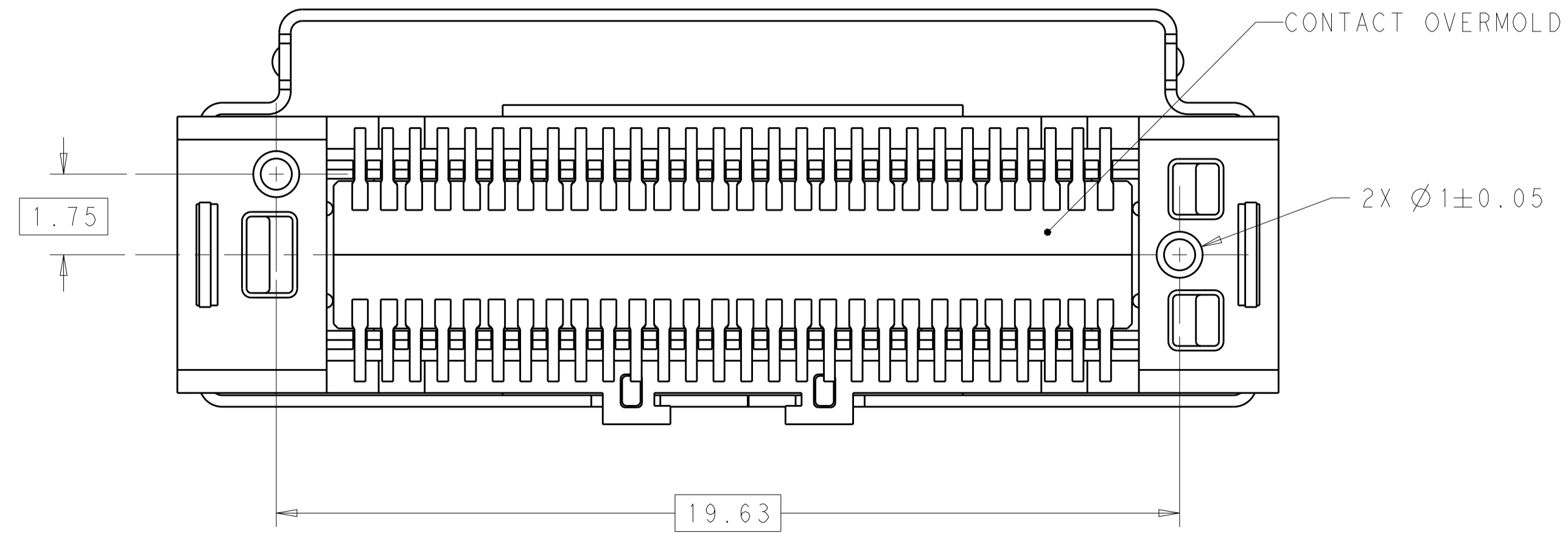
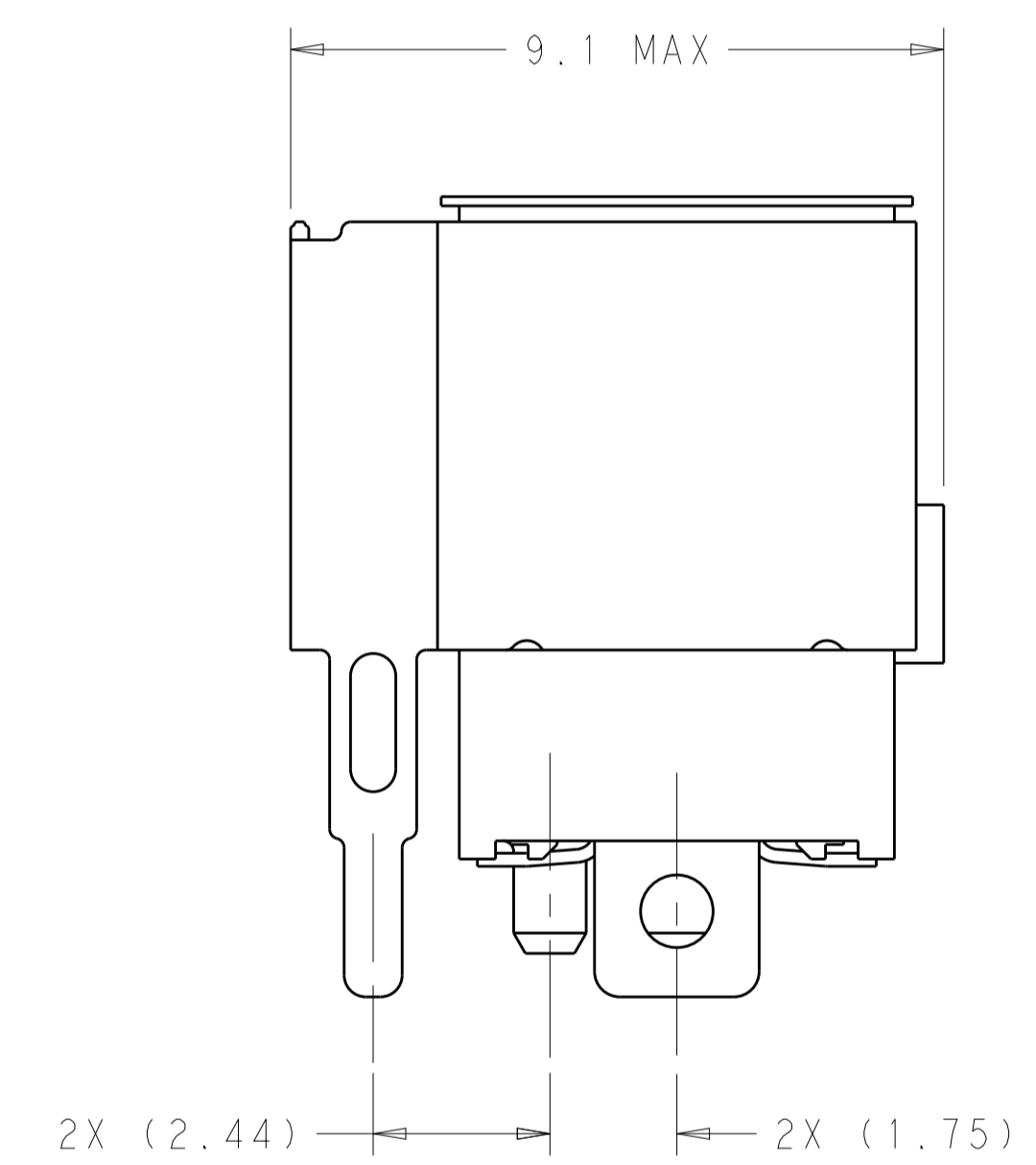
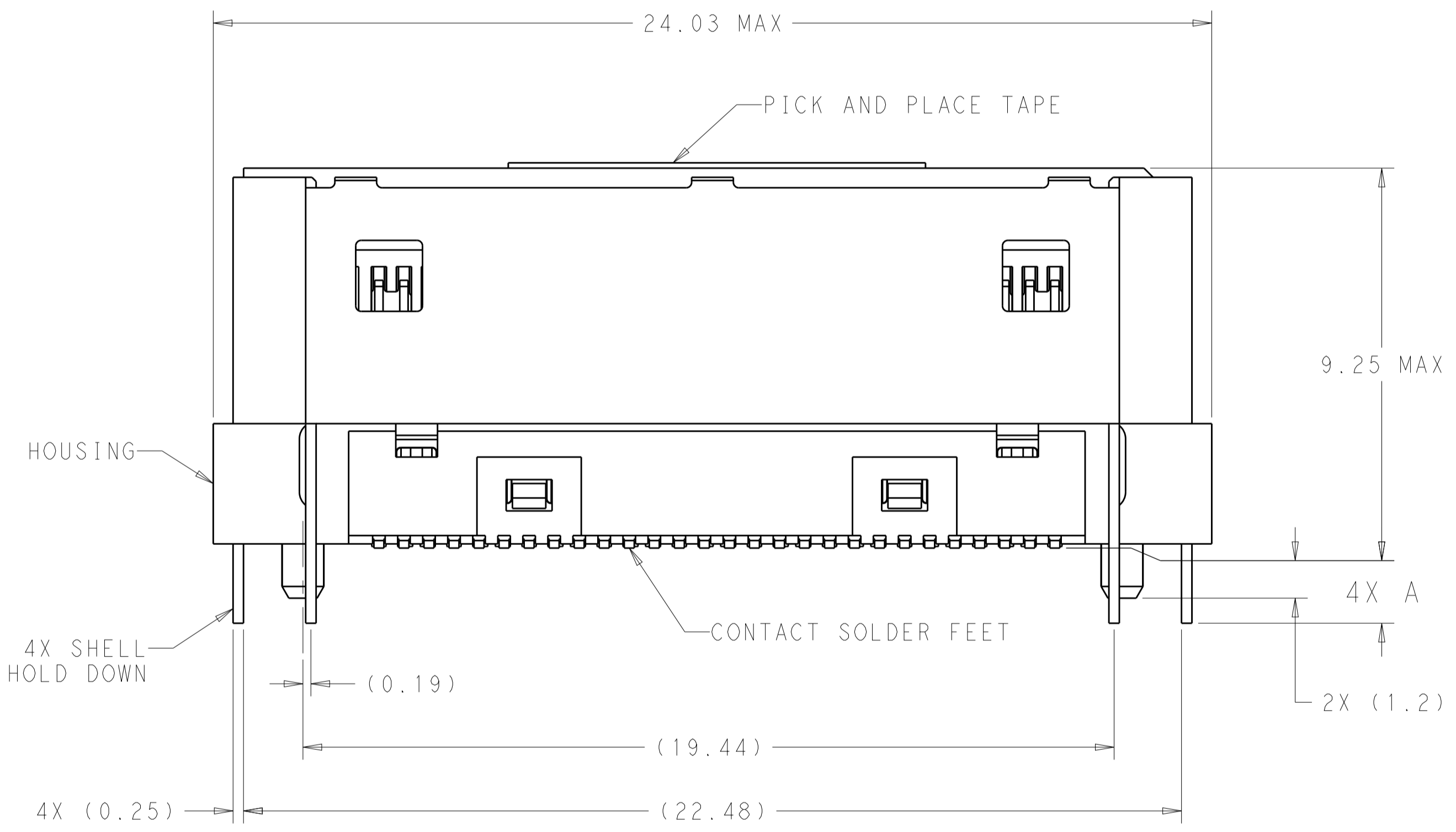

1.2±0.2	0.76µm Au	24	250	NO	200	1-2332141-6
	0.38µm Au				100	1-2332141-5
	FLASH Au/PdNi				50	1-2332141-4
1.8 +0.2/-0.1	0.76µm Au	24	250	NO	200	1-2332141-3
	0.38µm Au				100	1-2332141-2
	FLASH Au/PdNi				50	1-2332141-1
1.2±0.2	0.76µm Au	20	300	YES	200	2332141-6
	0.38µm Au				100	2332141-5
	FLASH Au/PdNi				50	2332141-4
1.8 +0.2/-0.1	0.76µm Au	20	300	YES	200	2332141-3
	0.38µm Au				100	2332141-2
	FLASH Au/PdNi				50	2332141-1
A	PLATING	POCKET TAPE PITCH	REEL QUANTITY	PICK AND PLACE TAPE	MATING CYCLES	PART NUMBER

THIS DRAWING IS A CONTROLLED DOCUMENT.

DIMENSIONS: mm

TOLERANCES UNLESS OTHERWISE SPECIFIED:

0 PLC	±
2 PLC	±
3 PLC	±
4 PLC	±
ANGLES	±

MATERIAL:

FINISH:

OWN: B. MATTHEWS, 27MAR2018

CHK: D. HARMON, 27MAR2018

APVD: D. HARMON, 27MAR2018

NAME: RECEPTACLE ASSEMBLY, VERTICAL, 56 POSITION, SLIVER 2.0

PRODUCT SPEC: 108-130021

APPLICATION SPEC: 114-130015

SIZE: A1

WEIGHT: -

CAGE CODE: 100779

DRAWING NO: 2332141

RESTRICTED TO: -

CUSTOMER DRAWING

SCALE: 10:1

SHEET: 1 OF 4

REV: B

REVISIONS				
P.	LTN	DESCRIPTION	DATE	APP'D
-	-	SEE SHEET 1	-	-

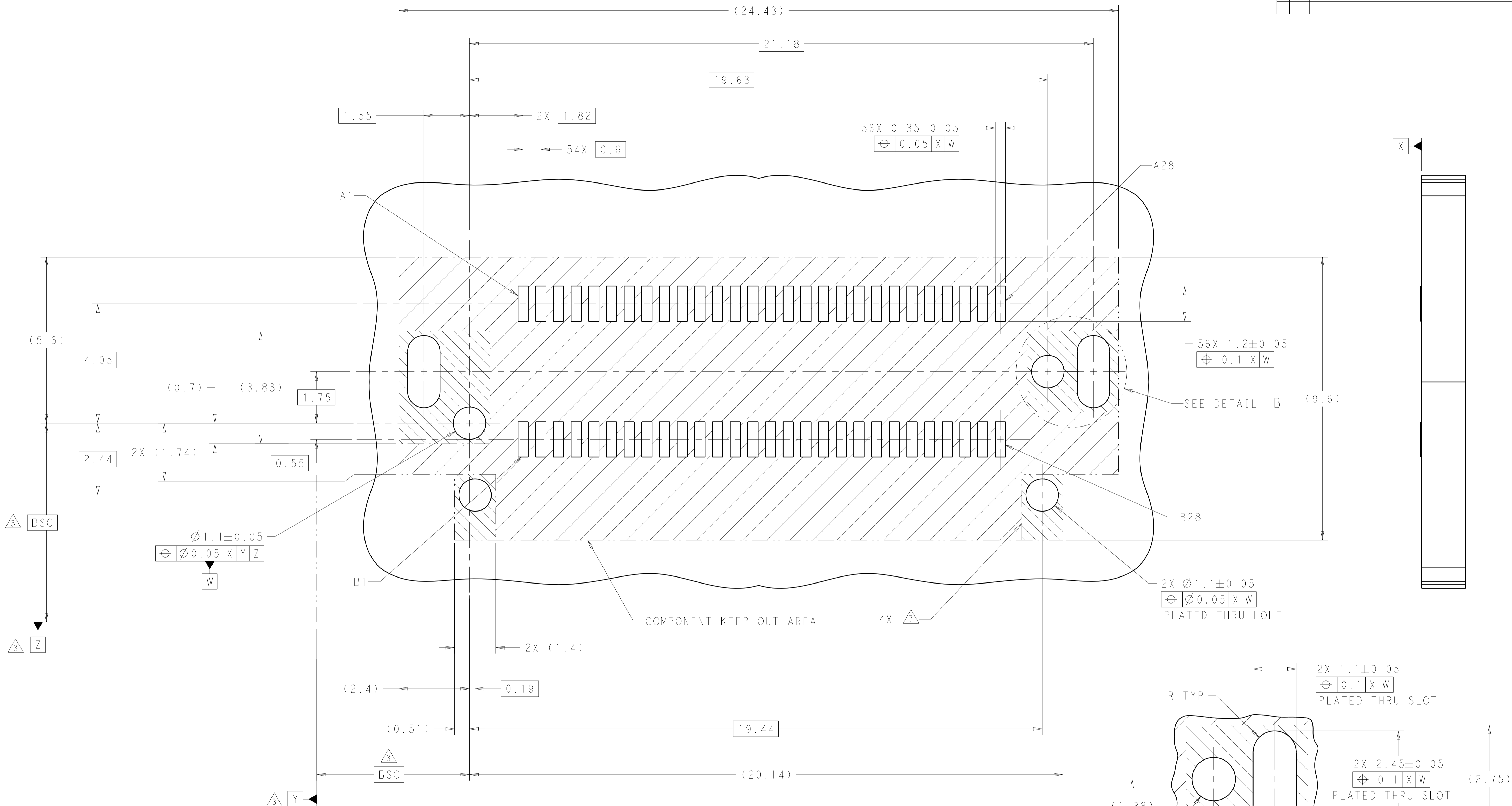

RECOMMENDED PCB LAYOUT
 AND KEEP OUT AREA
 SCALE 15:1

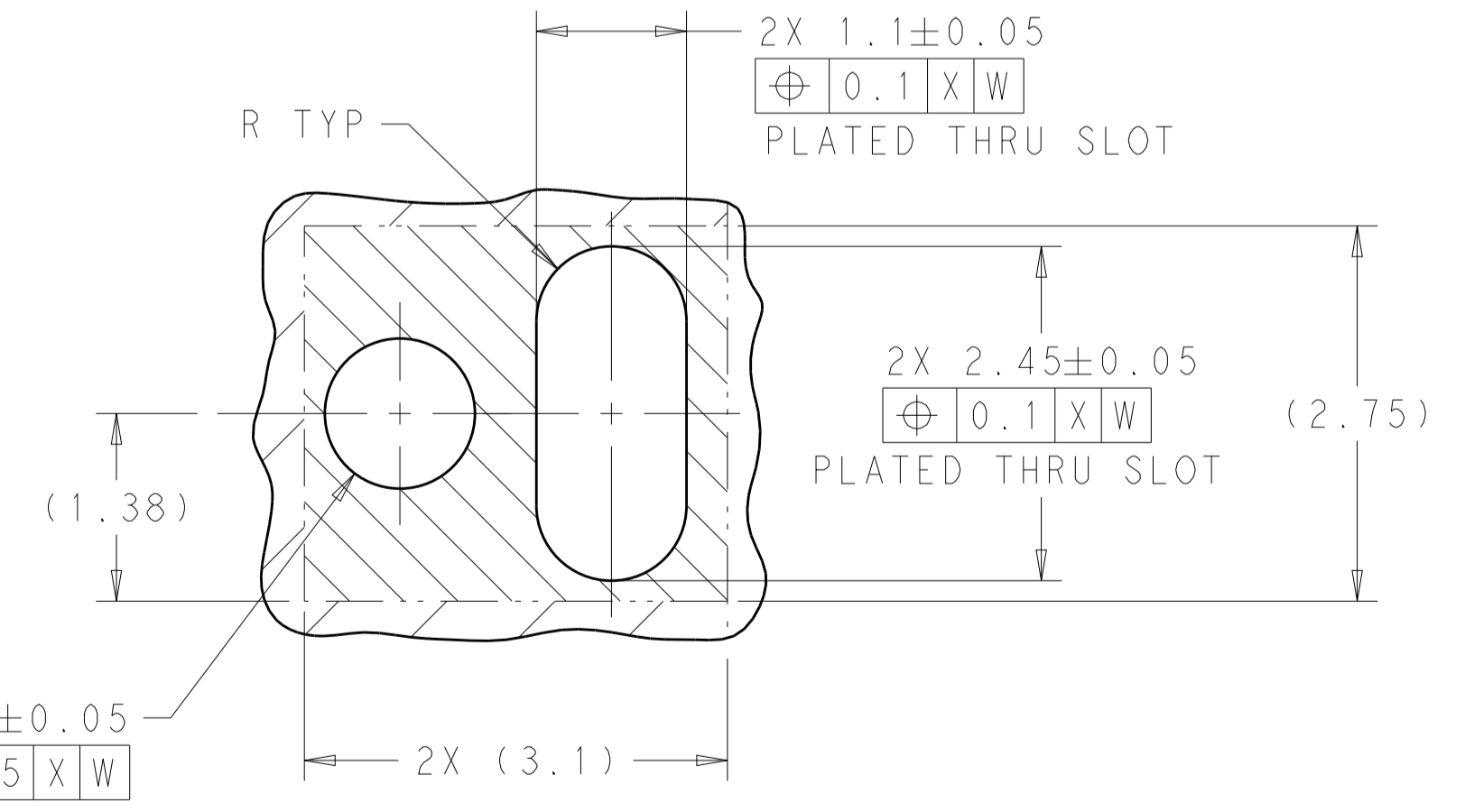

DETAIL B
 SCALE 20:1

THIS DRAWING IS A CONTROLLED DOCUMENT.		DWN B. MATTHEWS 27MAR2018	TE Connectivity
DIMENSIONS: mm		CHK D. HARMON 27MAR2018	
TOLERANCES UNLESS OTHERWISE SPECIFIED:		APVD D. HARMON 27MAR2018	NAME RECEPTACLE ASSEMBLY, VERTICAL, 56 POSITION, SLIVER 2.0
0 PLC ±	1 PLC ±	PRODUCT SPEC 108-130021	SIZE CAGE CODE DRAWING NO. RESTRICTED TO
2 PLC ±	3 PLC ±	APPLICATION SPEC 114-130015	A100779C=2332141
4 PLC ±	ANGLES ±	WEIGHT	SCALE 10:1 SHEET 2 OF 4 REV B
MATERIAL FINISH		CUSTOMER DRAWING	

REVISIONS				
P.	LTN.	DESCRIPTION	DATE	APVD.
-	-	SEE SHEET 1	-	-

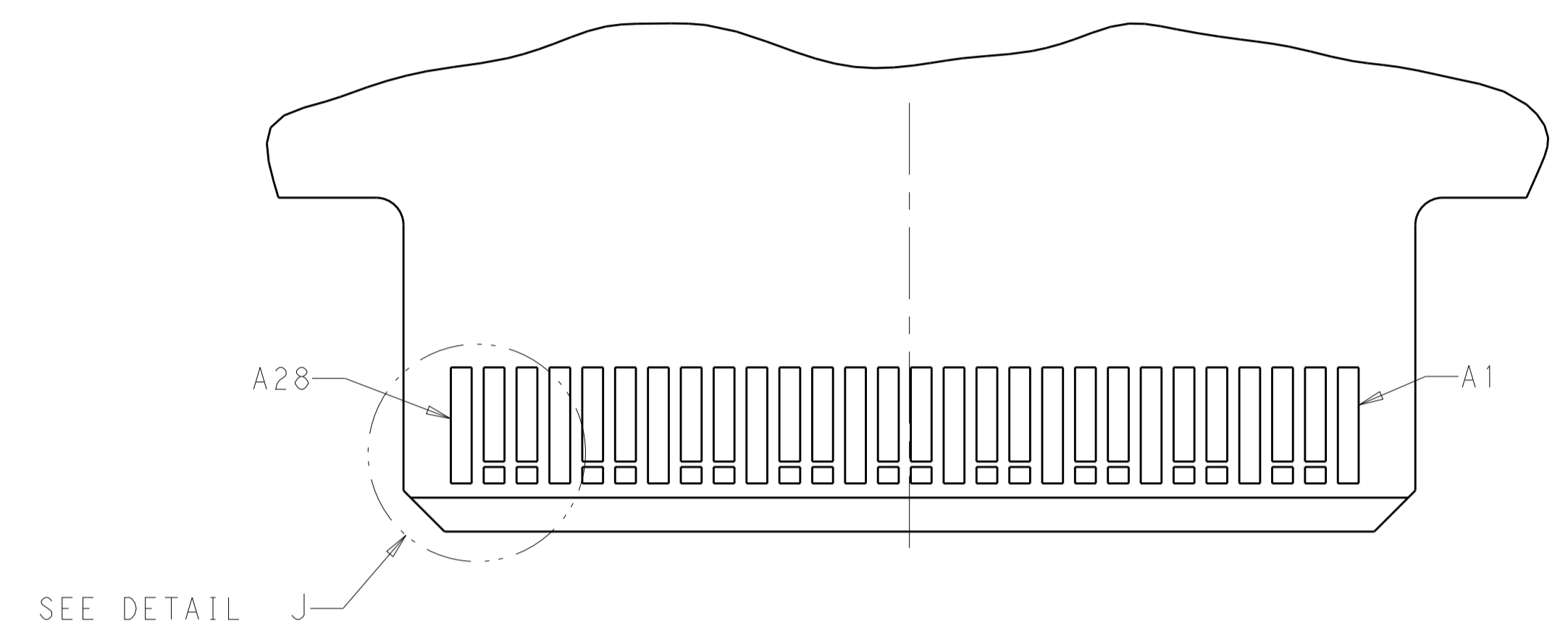
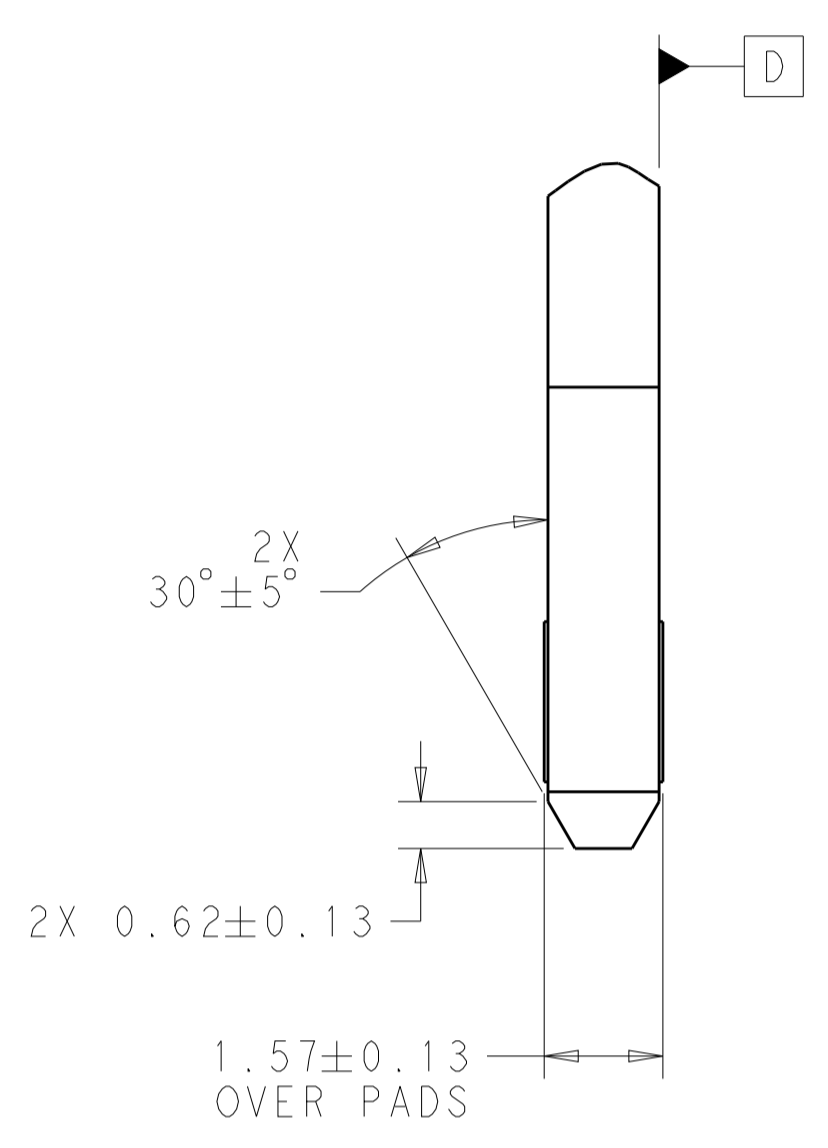
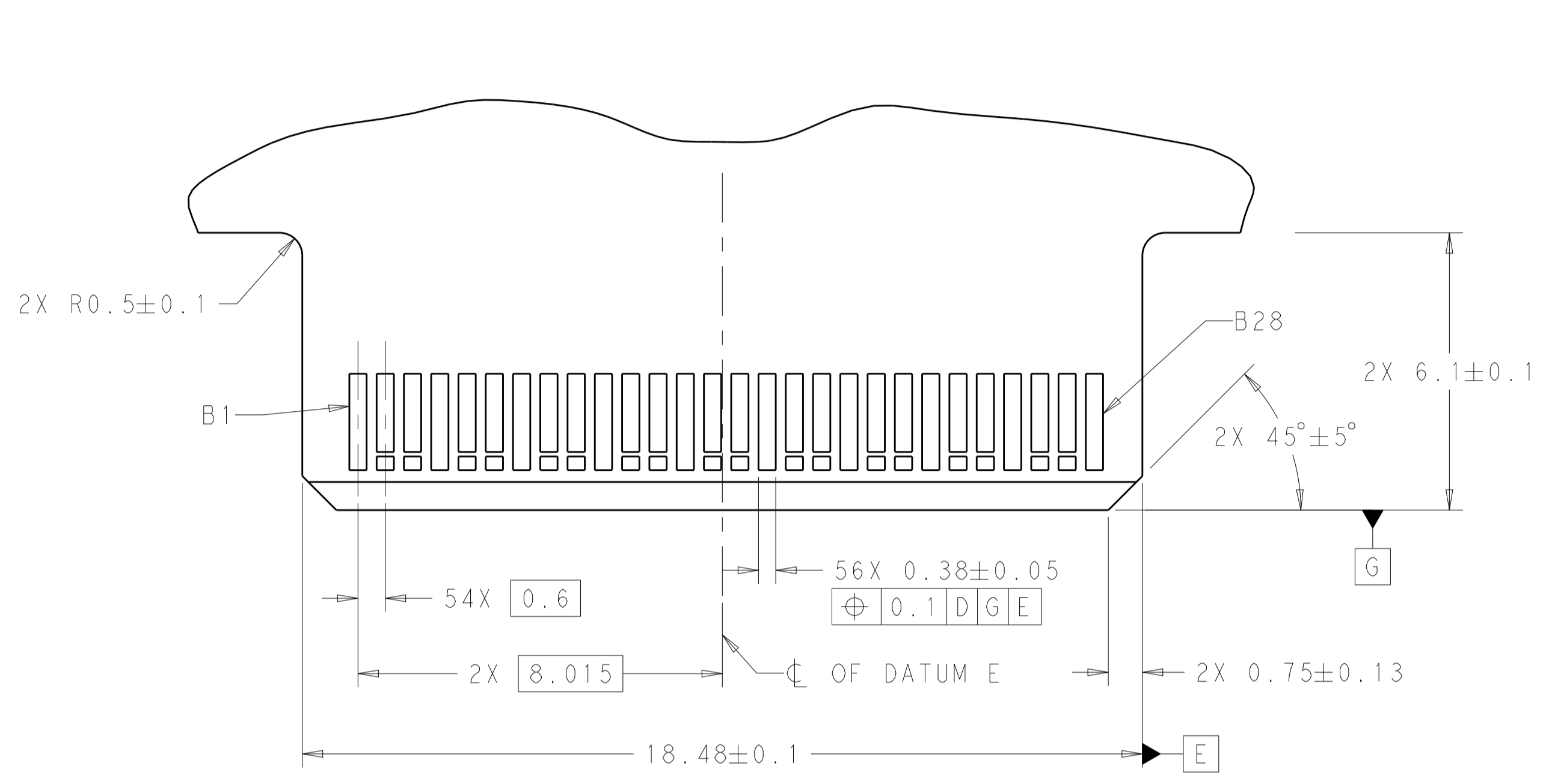

RECOMMENDED PCB OUTLINE DIMENSIONS.
 TOLERANCE VALUES ARE CRITICAL. PLEASE BE SURE TO DESIGNATE
 TOLERANCES TO PCB SUPPLIER TO ENSURE OPTIMIZED FUNCTIONALITY.

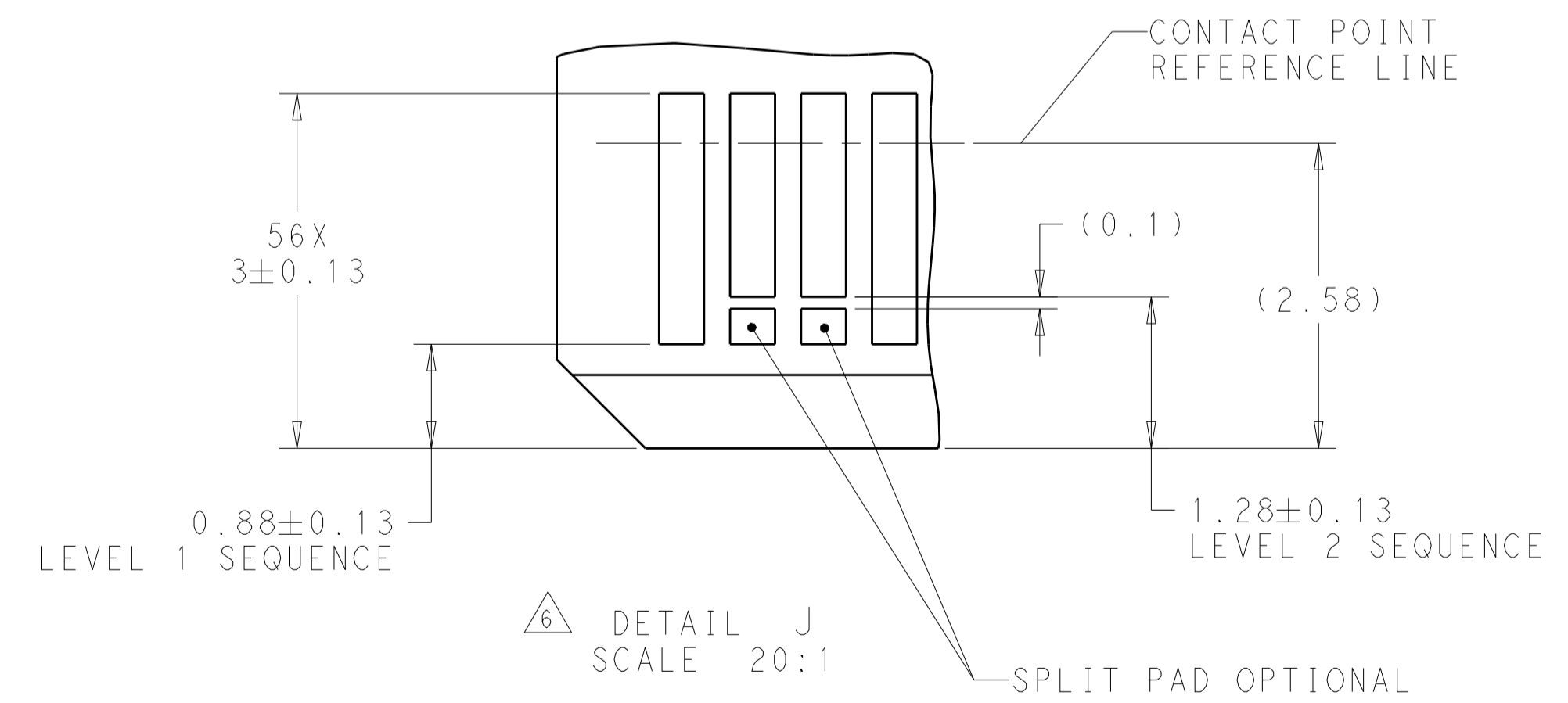

THIS DRAWING IS A CONTROLLED DOCUMENT.		DWN B. MATTHEWS 27MAR2018	TE Connectivity
DIMENSIONS: mm		CHK D. HARMON 27MAR2018	
TOLERANCES UNLESS OTHERWISE SPECIFIED:		APVD D. HARMON 27MAR2018	NAME RECEPTACLE ASSEMBLY, VERTICAL, 56 POSITION, SLIVER 2.0
0 PLC ±	1 PLC ±	PRODUCT SPEC 108-130021	SIZE CAGE CODE DRAWING NO. RESTRICTED TO
2 PLC ±	3 PLC ±	APPLICATION SPEC 114-130015	A100779C=2332141
4 PLC ±	ANGLES ±	WEIGHT	SCALE 10:1 SHEET 3 OF 4 REV B
MATERIAL FINISH	FINISH	CUSTOMER DRAWING	

REVISIONS				
P.	LTN	DESCRIPTION	DATE	APVD
-	-	SEE SHEET 1	-	-

TABLE 1: CONNECTOR CONTACT IDENTIFICATION 

CONTACT NUMBER	SIDE A	SIDE B
1	GROUND	GROUND
2	SIGNAL	SIGNAL
3	SIGNAL	SIGNAL
4	GROUND	GROUND
5	SIGNAL	SIGNAL
6	SIGNAL	SIGNAL
7	GROUND	GROUND
8	SIGNAL	SIGNAL
9	SIGNAL	SIGNAL
10	GROUND	GROUND
11	SIGNAL	SIGNAL
12	SIGNAL	SIGNAL
13	GROUND	GROUND
14	SIGNAL	SIGNAL
15	SIGNAL	SIGNAL
16	GROUND	GROUND
17	SIGNAL	SIGNAL
18	SIGNAL	SIGNAL
19	GROUND	GROUND
20	SIGNAL	SIGNAL
21	SIGNAL	SIGNAL
22	GROUND	GROUND
23	SIGNAL	SIGNAL
24	SIGNAL	SIGNAL
25	GROUND	GROUND
26	SIGNAL	SIGNAL
27	SIGNAL	SIGNAL
28	GROUND	GROUND

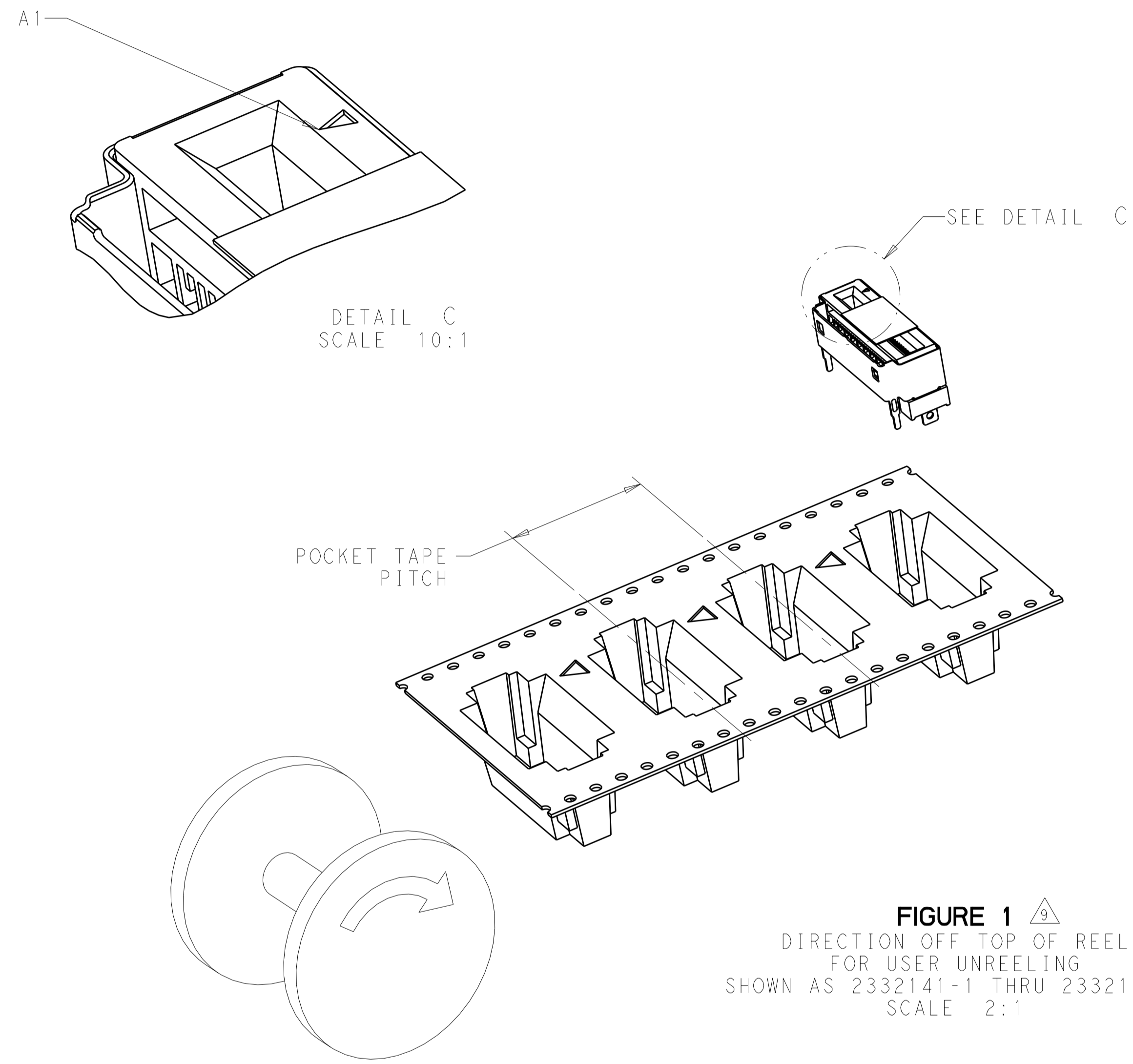



FIGURE 1 
 DIRECTION OFF TOP OF REEL
 FOR USER UNREELING
 SHOWN AS 2332141-1 THRU 2332141-6
 SCALE 2:1

THIS DRAWING IS A CONTROLLED DOCUMENT.		DWN: B. MATTHEWS 27MAR2018	 TE Connectivity
		CHK: D. HARMON 27MAR2018	
DIMENSIONS: mm		APVD: D. HARMON 27MAR2018	NAME: RECEPTACLE ASSEMBLY, VERTICAL, 56 POSITION, SLIVER 2.0
TOLERANCES UNLESS OTHERWISE SPECIFIED:		PRODUCT SPEC: 108-130021	RESTRICTED TO: -
0 PLC ±.015		APPLICATION SPEC: 114-130015	SIZE: A1
1 PLC ±.010		WEIGHT: -	CAGE CODE: 2332141
2 PLC ±.008		CUSTOMER DRAWING	SCALE: 10:1
3 PLC ±.005			SHEET 4 OF 4
4 PLC ±.003			REV B
ANGLES ±.005			
FINISH			

Mouser Electronics

Authorized Distributor

Click to View Pricing, Inventory, Delivery & Lifecycle Information:

[TE Connectivity:](#)

[2332141-1](#)