

LOC	DIST	REVISIONS					
GP	00	P	LTN	DESCRIPTION	DATE	DWN	APVD
		A		RELEASED FOR PRODUCTION	29FEB2016	TX	SH

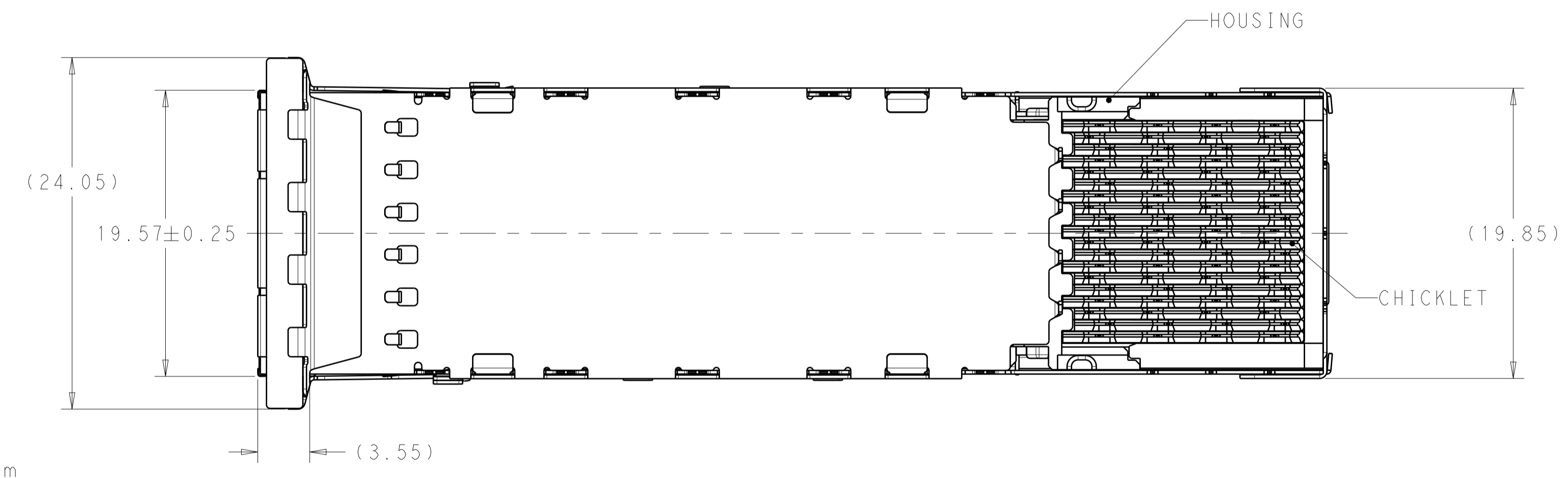
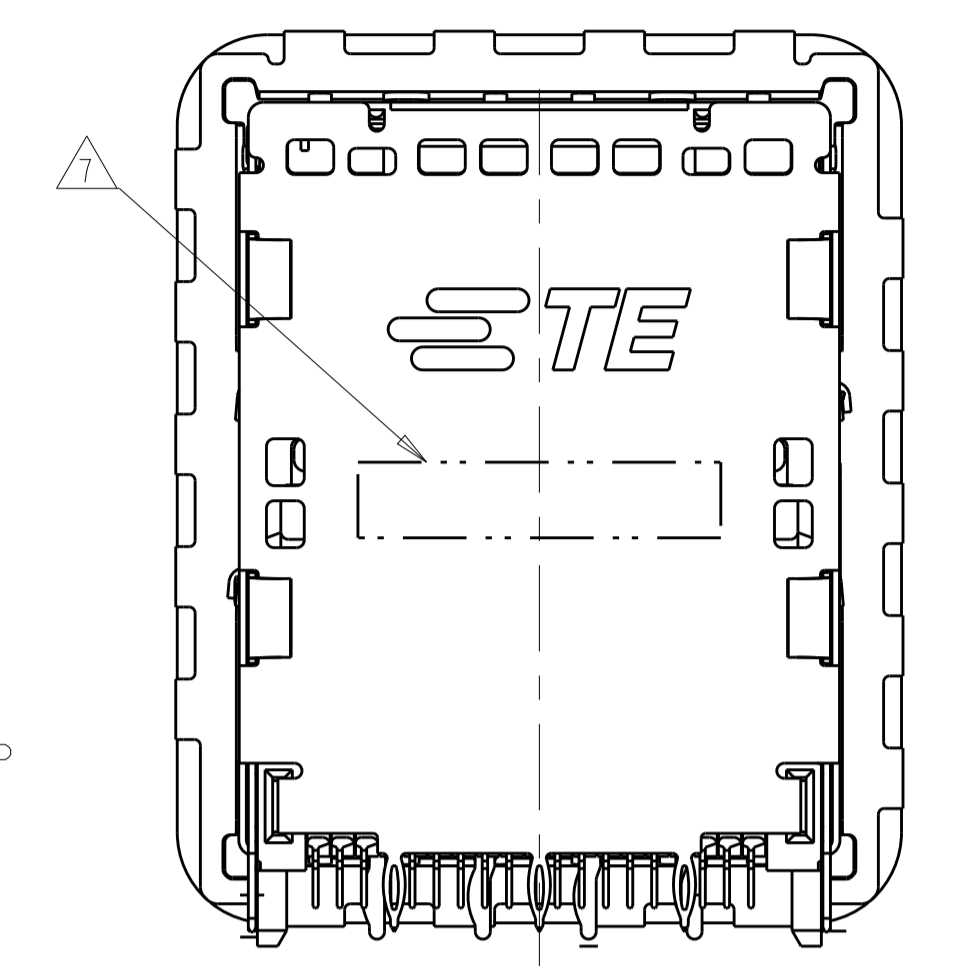
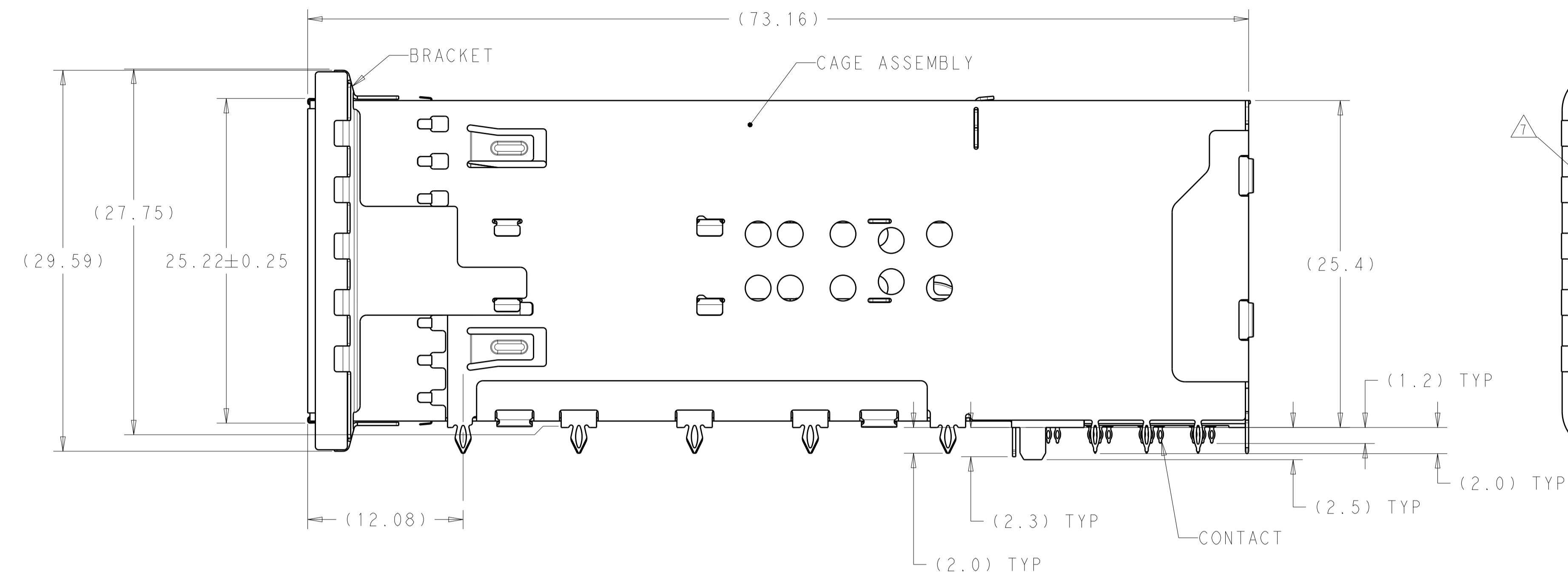
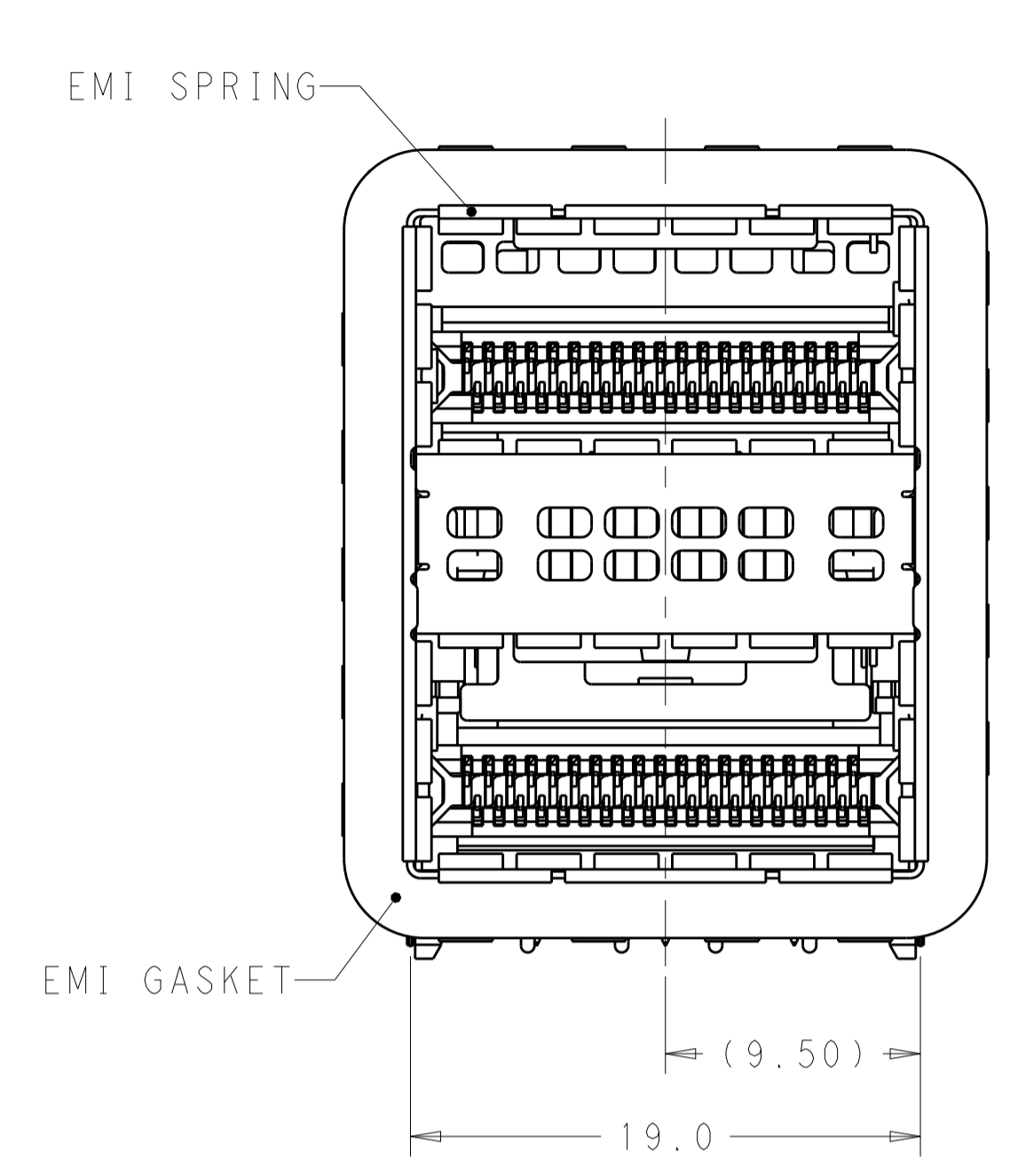

1. MATERIALS:
 CAGE ASSEMBLY- NICKEL SILVER ALLOY PER ASTM B 122.
 BRACKET- STAINLESS STEEL.
 EMI SPRING- COPPER ALLOY, NICKEL PLATED.
 EMI GASKET- PLATED FILLED SILICONE WITH 94V-0.
 HOUSING- POLYESTER LCP WITH 94V-0.
 CHICKLET- POLYESTER LCP WITH 94V-0.
 CONTACT- COPPER ALLOY.
 LIGHTPIPE- POLYCARBONATE WITH 94V-0.

- 2 CONTACT FINISH: 0.76µm GOLD ON MATING END, 1.25µm MATT TIN ON SOLDER TAIL, ALL OVER 1.27µm NICKEL.
 3 DATUM AND BASIC DIMENSION ESTABLISHED BY CUSTOMER.
 4. MINIMUM PCB THICKNESS OF 1.57.
 5 THE ENTIRE AREA OF THE CONNECTOR FOOTPRINT, INDICATED BY THE DASHED LINE, TO BE CONSIDERED THE KEEPOUT AREA FOR COMPONENTS.
 6 CROSS-HATCHED AREAS REPRESENT ZONES ON THE PCB THAT COME IN CONTACT WITH OR BE IN CLOSE PROXIMITY TO THE PLASTIC HOUSING OR THE CONNECTOR CAGE. INDICATED AREAS TO BE CONSIDERED TRACE FREE.
 7 PART NUMBER AND DATE CODE MARKED IN APPROXIMATE AREA SHOWN.
 8 HATCHED AREA IS PLACEMENT ZONE FOR LED. LED SHOULD BE CENTERED WITHIN ZONE. RECOMMEND 0805 PACKAGE.
 9 CONTACT FINISH: 0.08µm MINIMUM GOLD OVER 0.68µm PALLADIUM-NICKEL ON MATING END, 1.25µm MATT TIN ON SOLDER TAIL, ALL OVER 1.27µm NICKEL.

CONTACT FINISH	DESCRIPTION	PART NUMBER
9	LEFT INDICATOR DOWN	2198373-6
9	LEFT INDICATOR UP	2198373-5
9	NO LIGHTPIPE	2198373-4
2	LEFT INDICATOR DOWN	2198373-3
2	LEFT INDICATOR UP	2198373-2
2	NO LIGHTPIPE	2198373-1

THIS DRAWING IS A CONTROLLED DOCUMENT. DIMENSIONING AND TOLERANCING PER ASME Y14.5M-2009. TOLERANCES UNLESS OTHERWISE SPECIFIED:

DIMENSIONS:	mm	0 PLC ±0.25 1 PLC ±0.15 2 PLC ±0.15 3 PLC ±0.15 4 PLC ±0.15
ANGLES:	°	±0.5
MATERIAL:	SEE NOTE 1	

DWN: M. SHIRK 01NOV2011	CHK: D. SZCZESNY 01NOV2011	APVD: -
PRODUCT SPEC		
APPLICATION SPEC		
SIZE: A1	CAGE CODE: 00779	DRAWING NO: 2198373
CUSTOMER DRAWING		

TE TE Connectivity
 CAGE AND CONNECTOR ASSEMBLY, WITH EMI GASKET, 2X1, ZQSFP+ STACKED
 SCALE 4:1 SHEET 1 OF 4 REV A

LOC		DIST		REVISIONS			
P.	LTN	DESCRIPTION	DATE	DWN	APVD		
-	-	SEE SHEET 1	-	-	-		

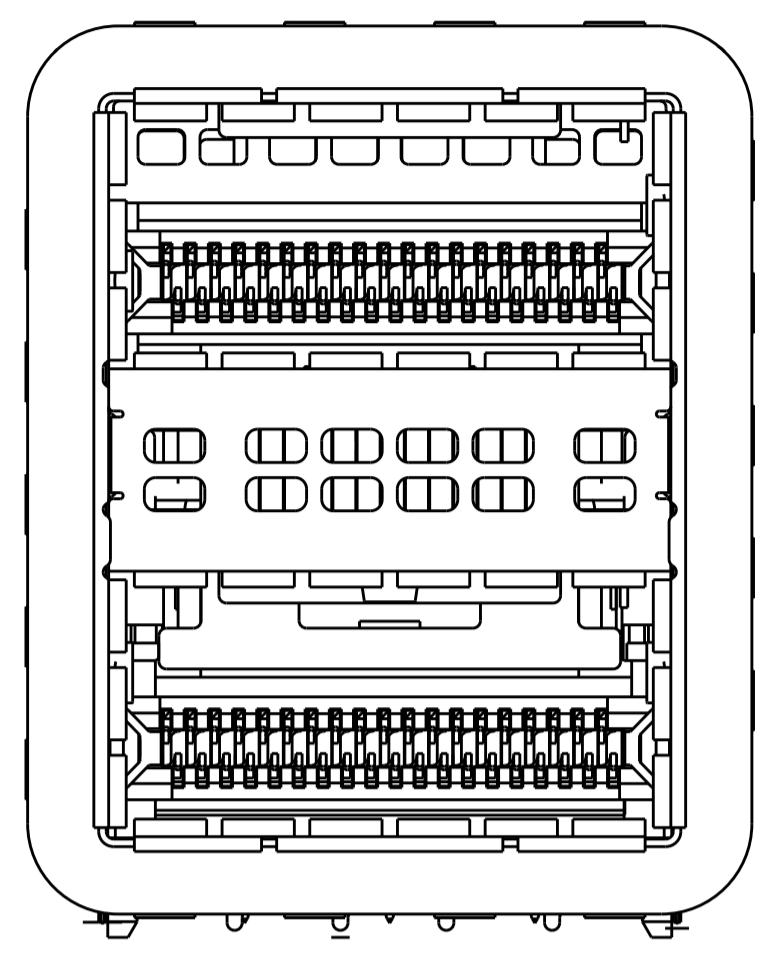

2198373-1 / 2198373-4
NO LIGHTPIPE IN ASSEMBLY

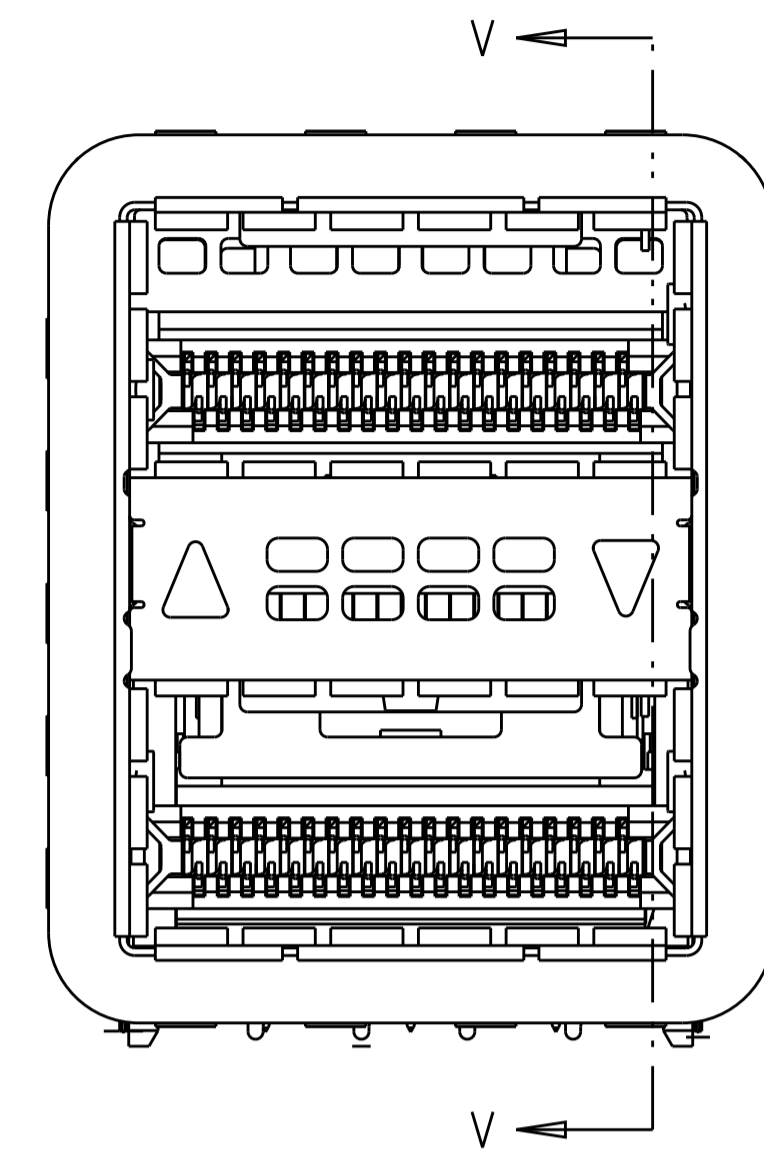

2198373-2 / 2198373-5
LEFT LIGHTPIPE INDICATOR
POINTING TO UPPER PORT

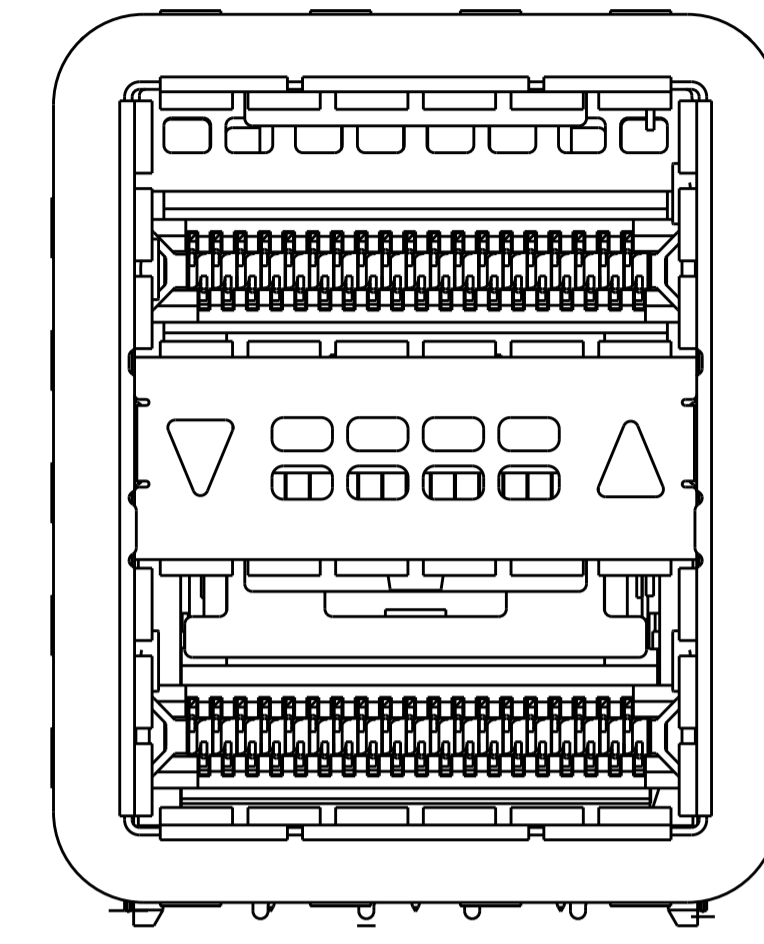

2198373-3 / 2198373-6
LEFT LIGHTPIPE INDICATOR
POINTING TO LOWER PORT

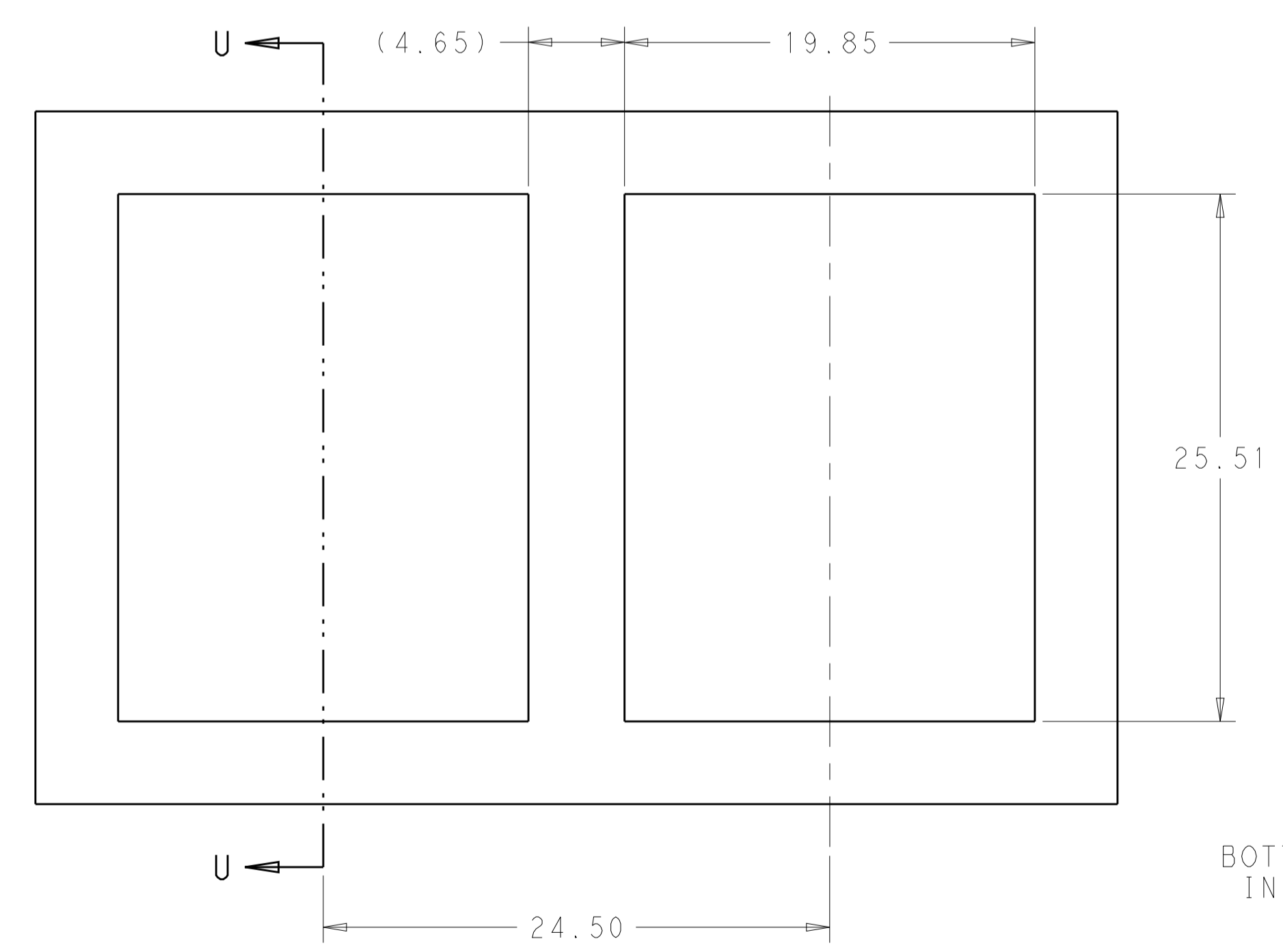

RECOMMENDED PANEL CUTOUT
AND PC BOARD, PANEL POSITION

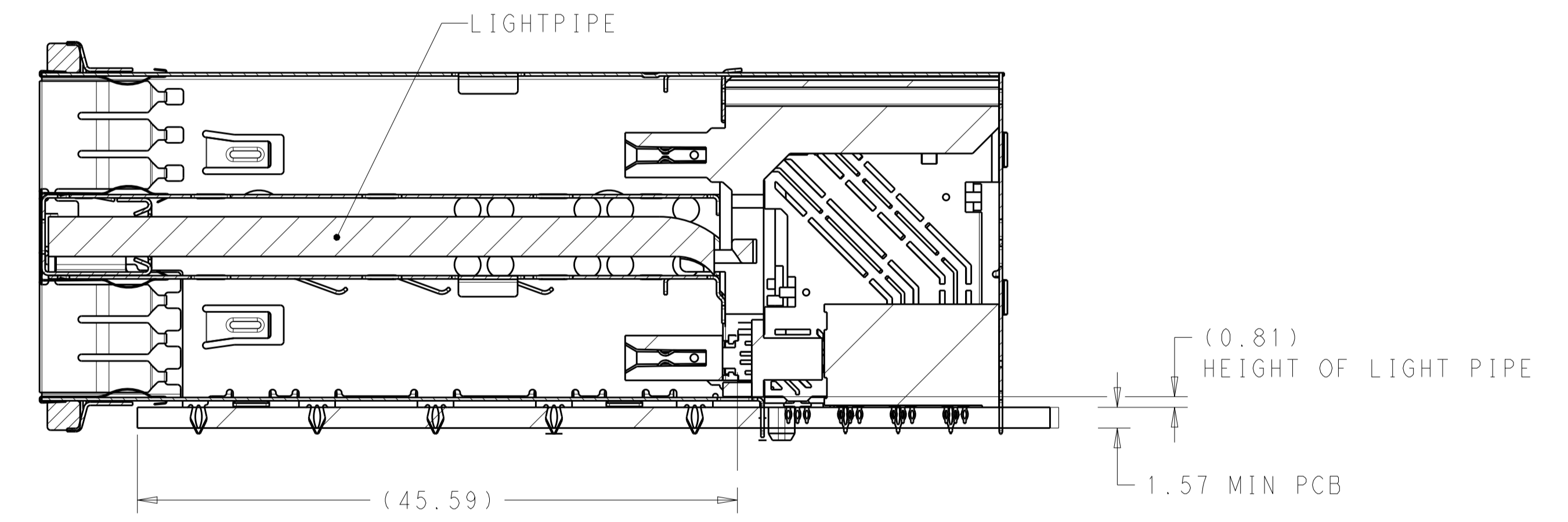

SECTION V-V
SCALE 3:1

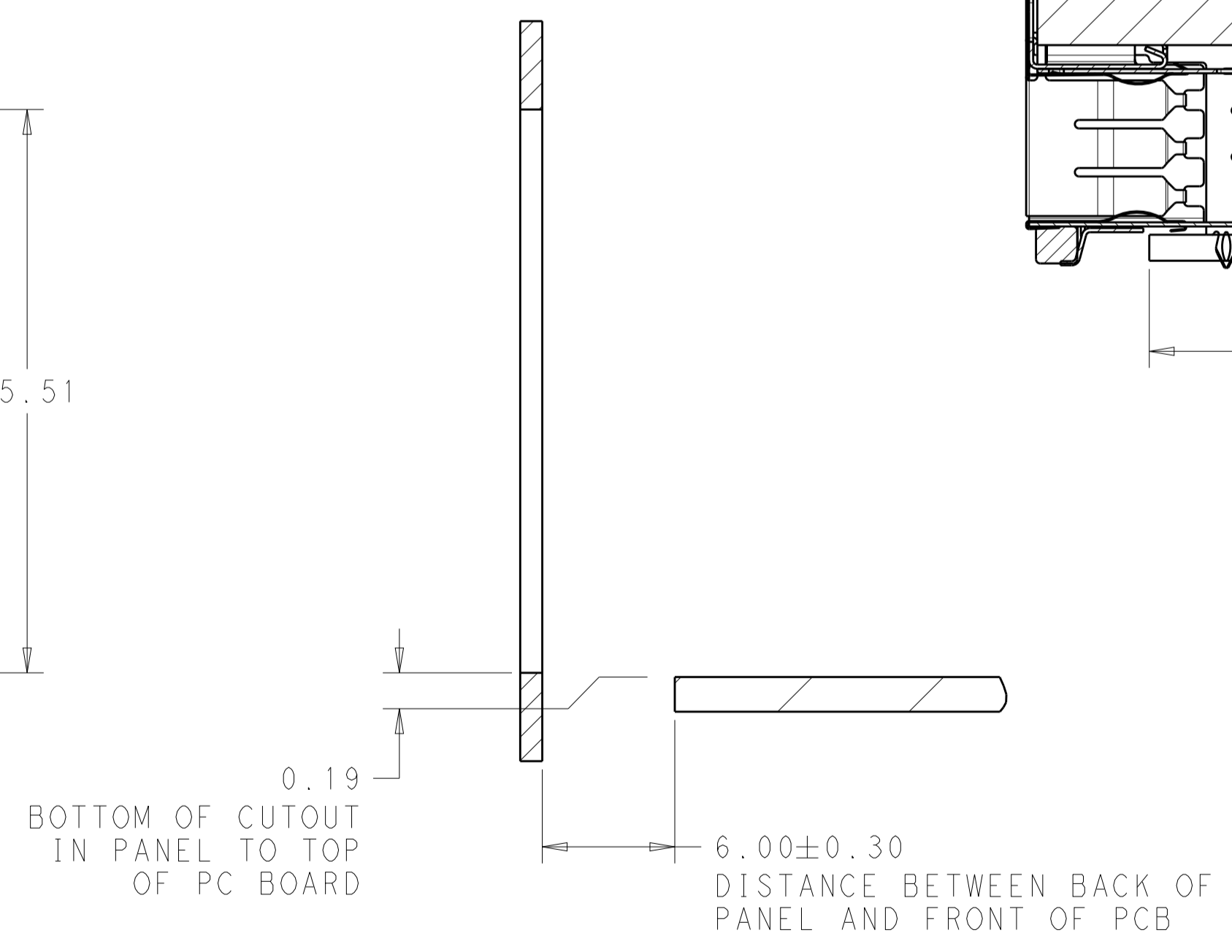

SECTION U-U

THIS DRAWING IS A CONTROLLED DOCUMENT. DIMENSIONING AND TOLERANCING PER ASME Y14.5M-2009		DWN: M. SHIRK 01NOV2011 CHK: D. SZCZESNY 01NOV2011	TE Connectivity NAME: CAGE AND CONNECTOR ASSEMBLY, WITH EMI GASKET, 2X1, ZQSFP+ STACKED
DIMENSIONS: mm		APVD: -	
TOLERANCES UNLESS OTHERWISE SPECIFIED:		PRODUCT SPEC: -	SIZE: A1
0 PLC ±		APPLICATION SPEC: -	CAGE CODE: 100779
1 PLC ±0.25		WEIGHT: -	DRAWING NO: C=2198373
2 PLC ±0.15		CUSTOMER DRAWING	SCALE: 4:1
3 PLC ±			SHEET: 2 OF 4
4 PLC ±			REV: A
ANGLES ±			
FINISH: -			
SEE NOTE 1			

LOC		DIST		REVISIONS			
P	LTN	DESCRIPTION	DATE	DMN	APVD		
-	-	SEE SHEET 1	-	-	-		

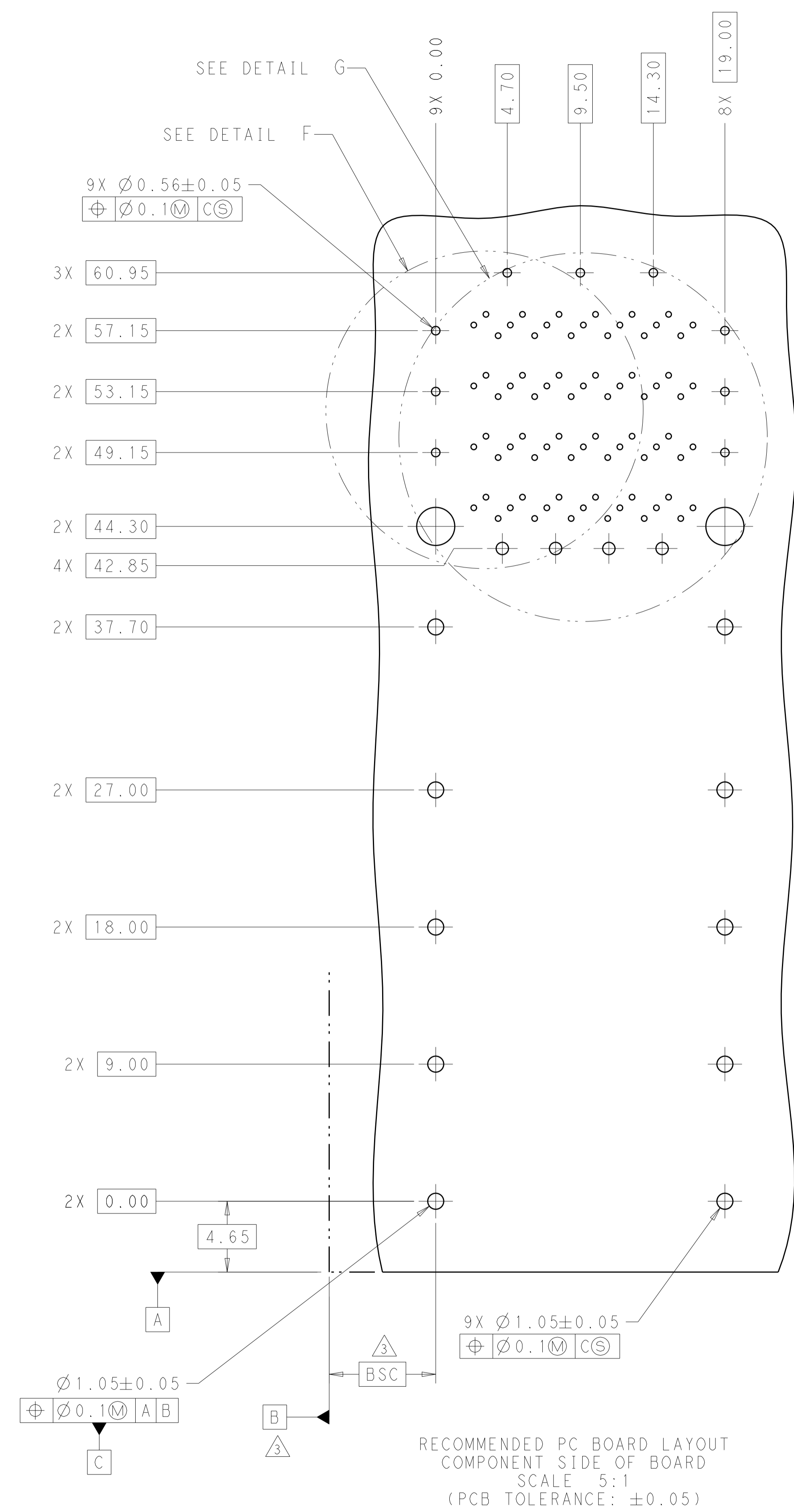

RECOMMENDED PC BOARD LAYOUT
 COMPONENT SIDE OF BOARD
 SCALE 5:1
 (PCB TOLERANCE: ± 0.05)

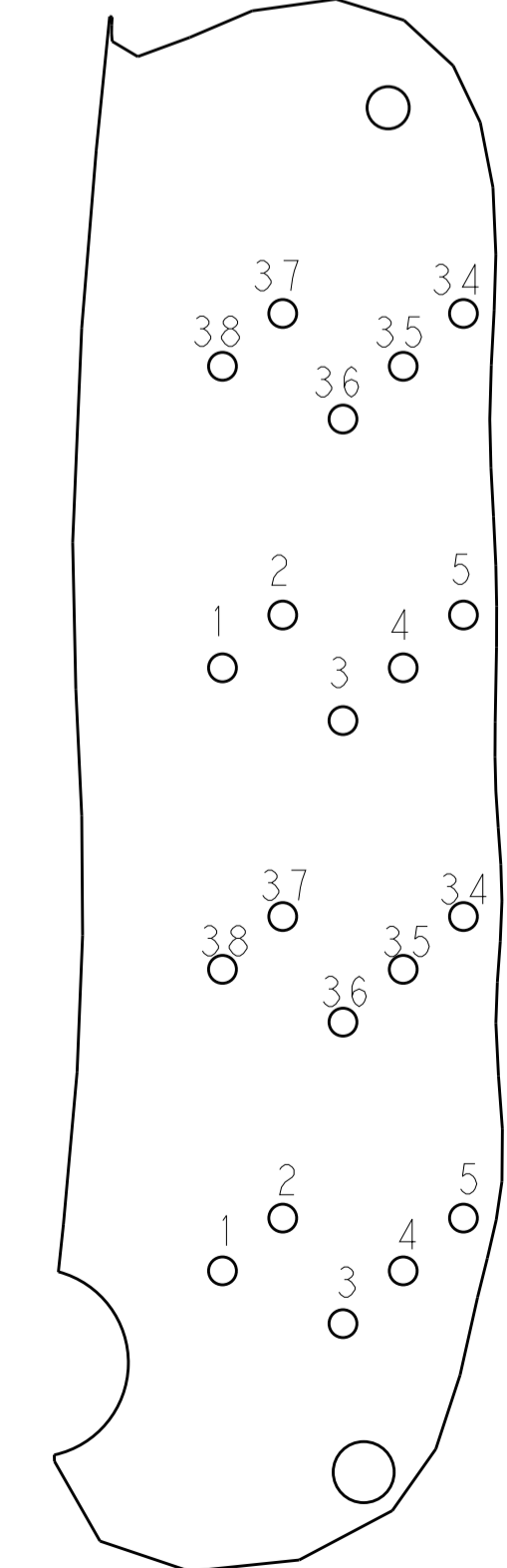
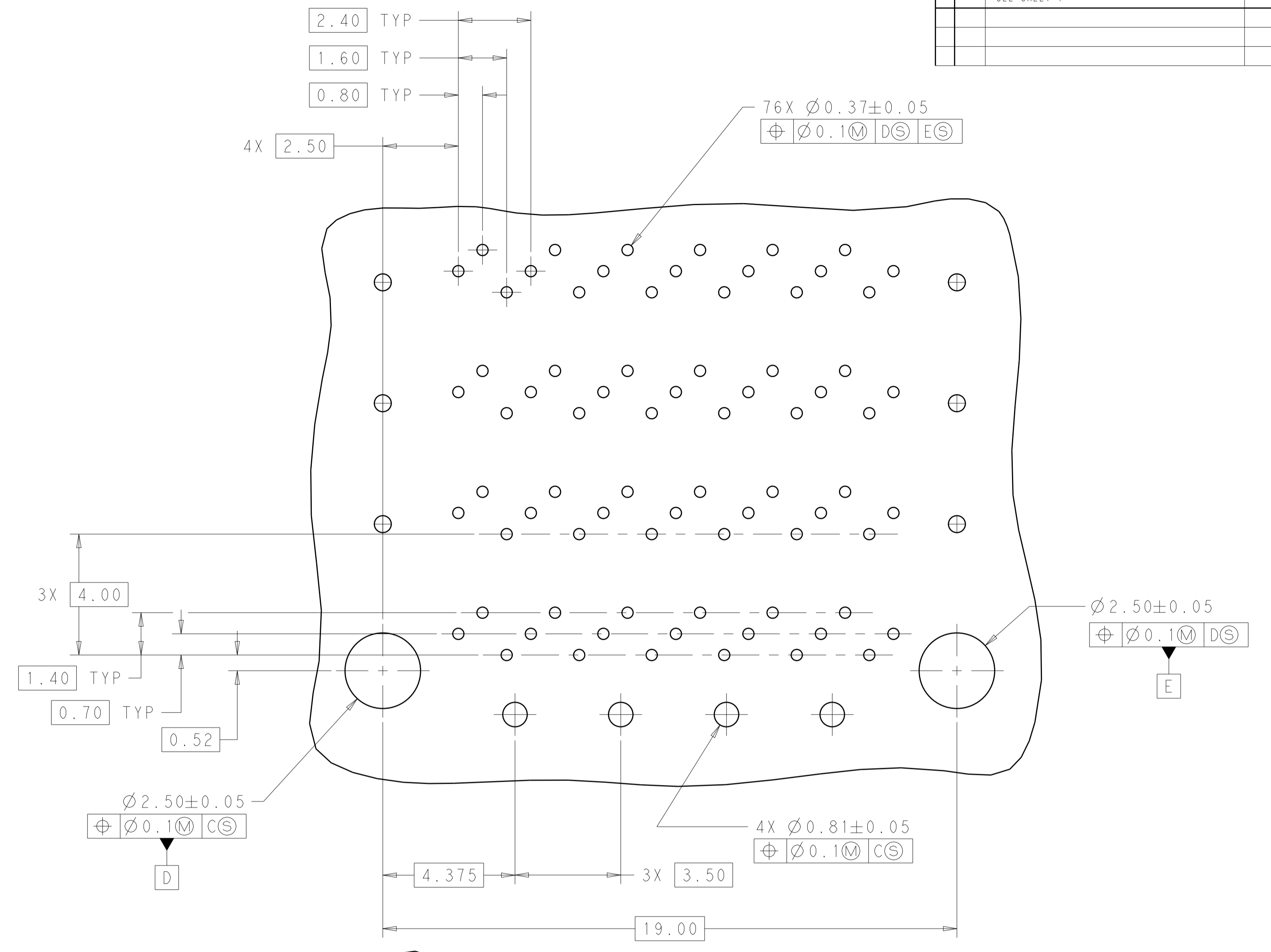

DETAIL F
 SCALE 10:1
 PIN ASSIGNMENTS

THIS DRAWING IS A CONTROLLED DOCUMENT. DIMENSIONING AND TOLERANCING PER ASME Y14.5M-2009		DMN: M. SHIRK 01NOV2011 CHK: D. SZCZESNY 01NOV2011	TE Connectivity	
DIMENSIONS: mm	TOLERANCES UNLESS OTHERWISE SPECIFIED:	APVD: -	NAME: CAGE AND CONNECTOR ASSEMBLY, WITH EMI GASKET, 2X1, ZQSP+ STACKED	
0 PLC \pm 1 PLC ± 0.25 2 PLC ± 0.15 3 PLC \pm 4 PLC \pm ANGLES \pm		PRODUCT SPEC: -	SIZE: CAGE CODE: DRAWING NO: A100779C=2198373	
MATERIAL: -	FINISH: -	APPLICATION SPEC: -	WEIGHT: -	RESTRICTED TO: -
SEE NOTE 1		CUSTOMER DRAWING	SCALE: 4:1	SHEET 3 OF 4 REV A

LOC	DIST	REVISIONS			
P	LTN	DESCRIPTION	DATE	DWN	APVD
-	-	SEE SHEET 1	-	-	-

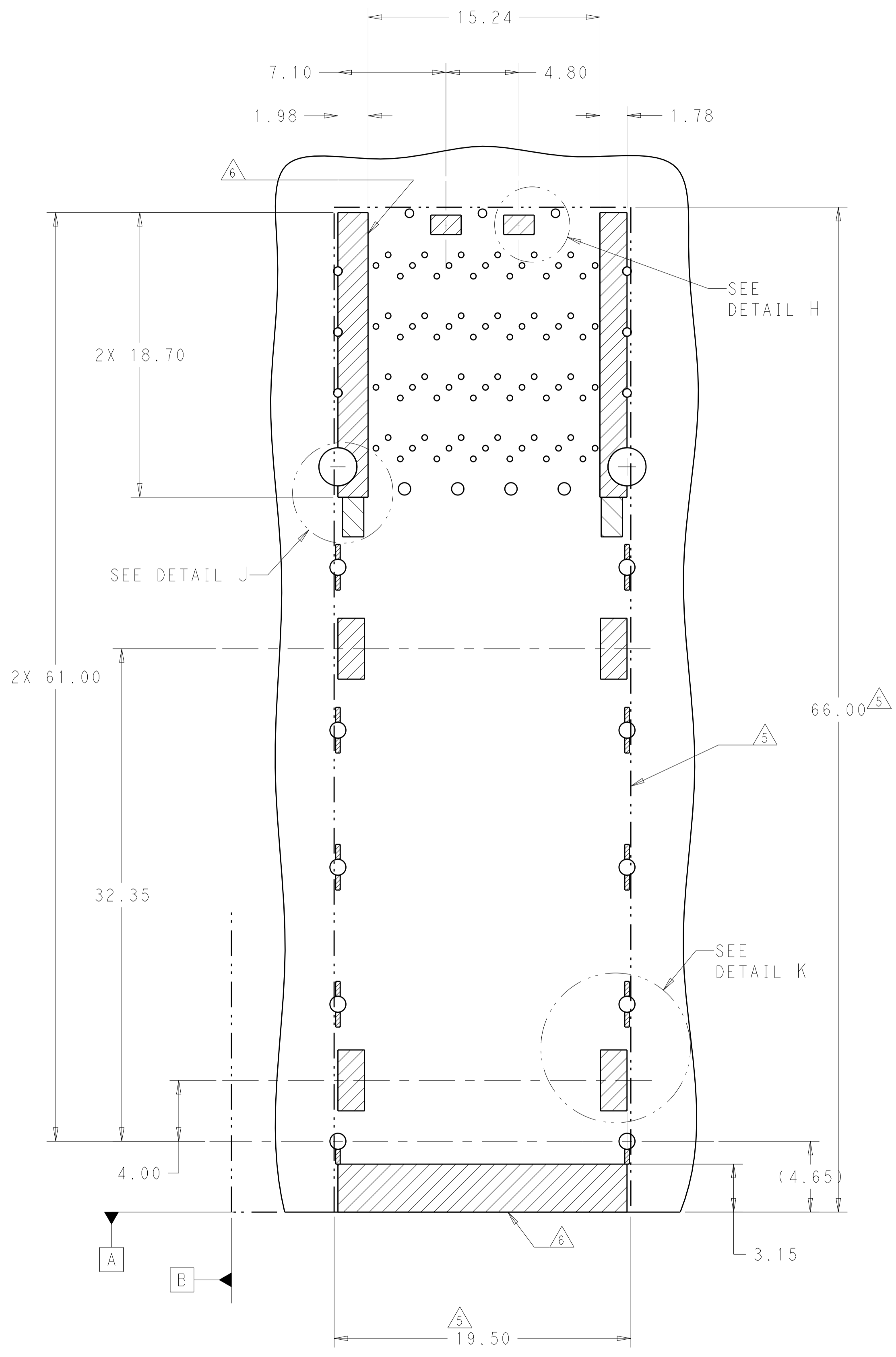

KEEPOUT AREAS
 COMPONENT SIDE OF BOARD
 SCALE 5:1

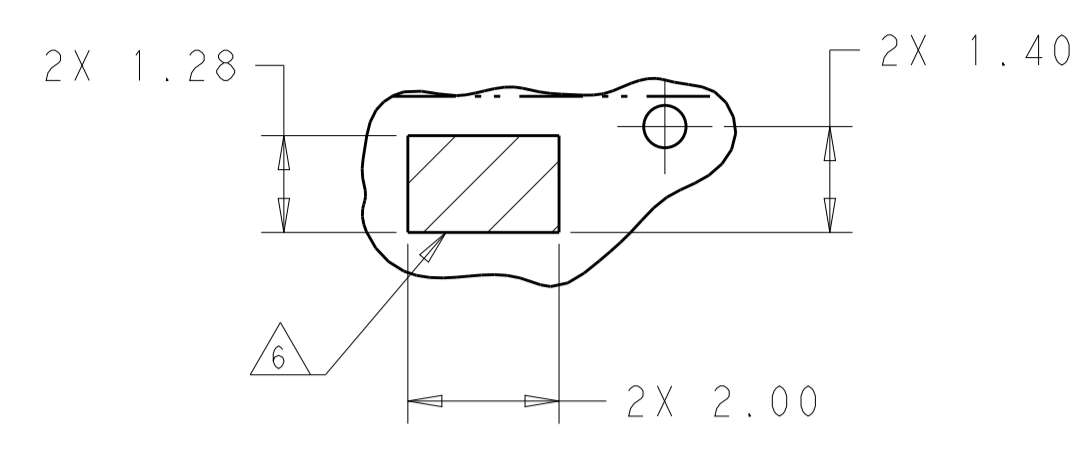

DETAIL H
 SCALE 10:1

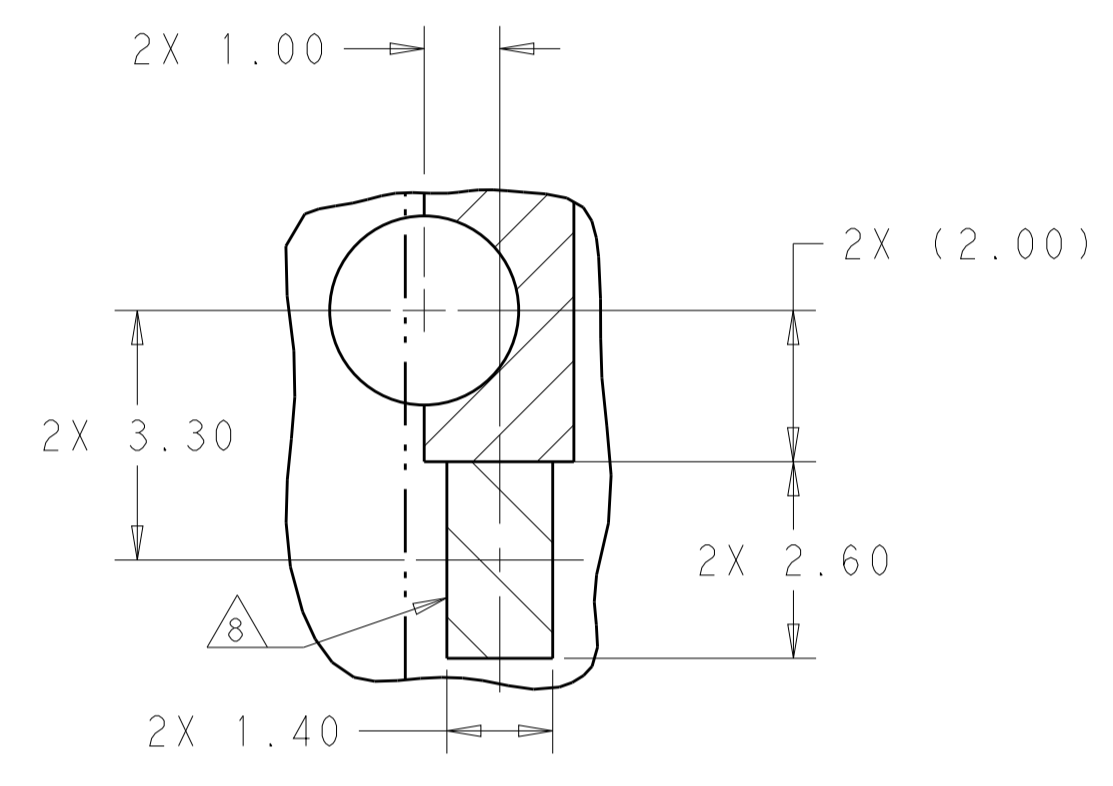

DETAIL J
 LED PADS
 SCALE 10:1

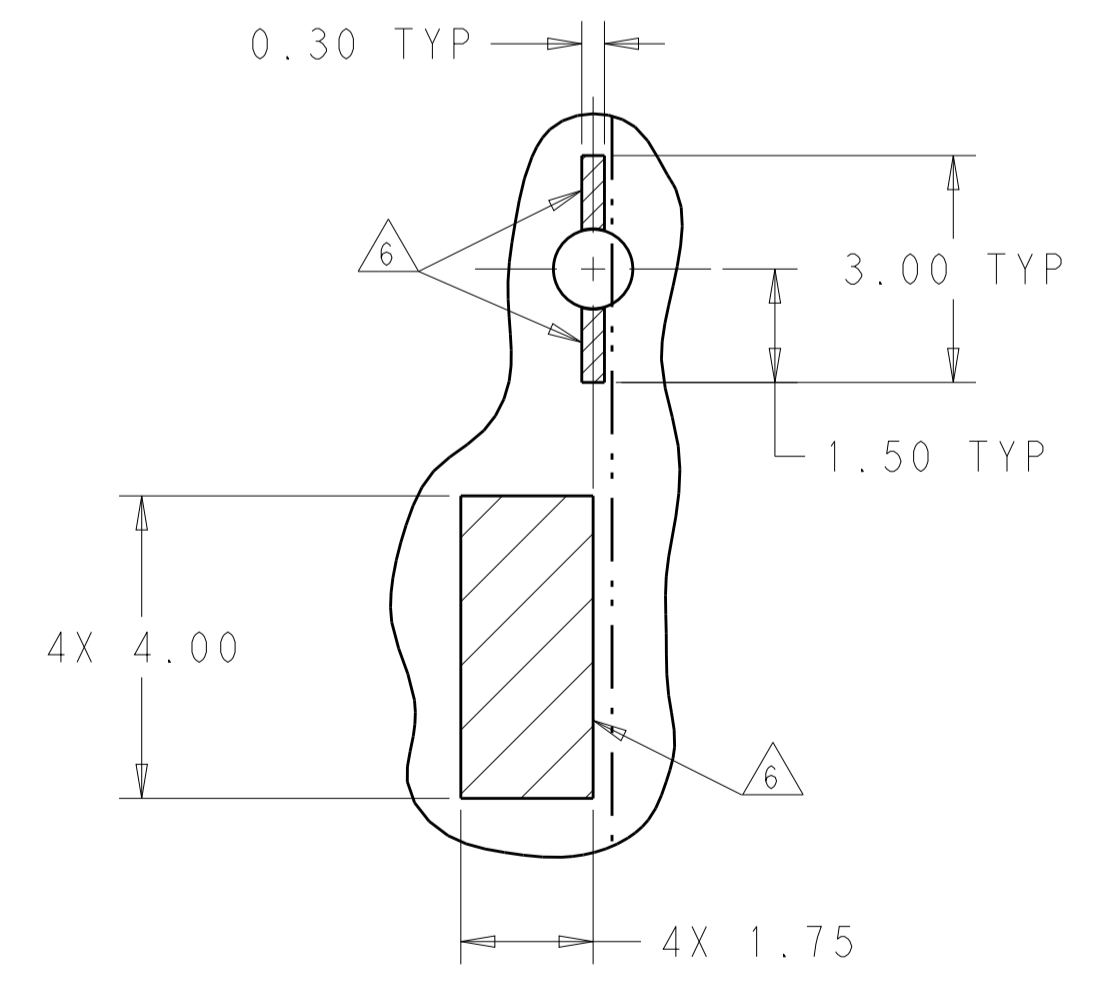

DETAIL K
 SCALE 10:1

THIS DRAWING IS A CONTROLLED DOCUMENT. DIMENSIONING AND TOLERANCING PER ASME Y14.5M-2009		DWN: M. SHIRK 01NOV2011 CHK: D. SZCZESNY 01NOV2011	TE Connectivity NAME: CAGE AND CONNECTOR ASSEMBLY, WITH EMI GASKET, 2X1, ZQSFP+ STACKED
DIMENSIONS: mm	TOLERANCES UNLESS OTHERWISE SPECIFIED:	APVD: -	
0 PLC ±0.25 1 PLC ±0.15 2 PLC ±0.15 3 PLC ±0.15 4 PLC ±0.15	ANGLES ±0.5°	PRODUCT SPEC: - APPLICATION SPEC: -	RESTRICTED TO: -
MATERIAL: - FINISH: - SEE NOTE 1	WEIGHT: -	SIZE: A100779 CAGE CODE: C=2198373 CUSTOMER DRAWING	SCALE: 4:1 SHEET: 4 OF 4 REV: A

Mouser Electronics

Authorized Distributor

Click to View Pricing, Inventory, Delivery & Lifecycle Information:

[TE Connectivity:](#)

[2198373-1](#)