

THIS DRAWING IS UNPUBLISHED. RELEASED FOR PUBLICATION 20
 © COPYRIGHT 20 BY - ALL RIGHTS RESERVED.

REVISIONS					
P	LTR	DESCRIPTION	DATE	DWN	APVD
A		RELEASE	31OCT2016	JY	SH
B		ADD NEW PN 4-2170808-7	21MAY2019	JY	SH

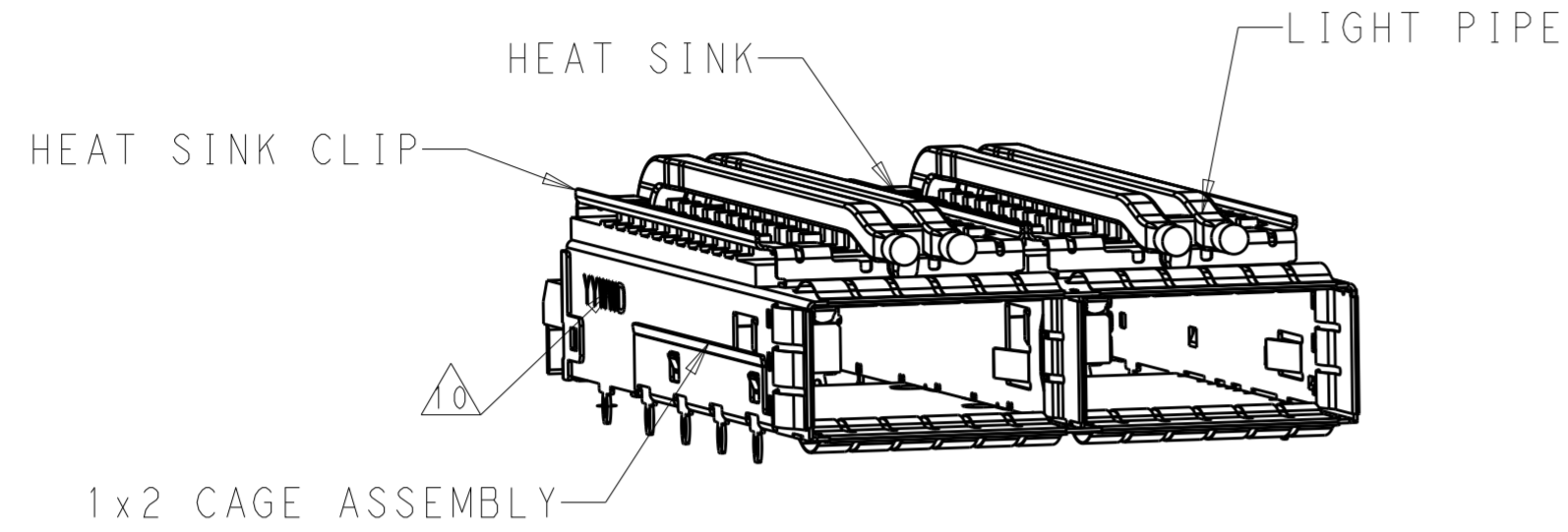

2-2170808-1 AS SHOWN
 SCALE 2:1

- COMPONENTS
 CAGE ASSEMBLY: NICKEL-SILVER ALLOY
 HEAT SINK: ALUMINUM/BLACK ANODIZE
 HEAT SINK CLIP: STAINLESS STEEL
 EMI SPRING: COPPER ALLOY/NICKEL PLATE
 LIGHT PIPE: CLEAR POLYCARBONATE
- REFERENCE APPLICATION SPECIFICATION 114-32023 FOR RECOMMENDED DRILL HOLE DIAMETER AND PLATING THICKNESS
- DATUM AND BASIC DIMENSION ESTABLISHED BY CUSTOMER
- DIMENSION APPLIES WITH MODULE INSERTED IN CAGE
- HEAT SINKS, HEAT SINK CLIPS AND LIGHT PIPES ARE SHIPPED ASSEMBLED ON CAGE
- MINIMUM PC BOARD THICKNESS: SINGLE SIDED: 1.57 MIN
 DOUBLE SIDED: 2.20 MIN
- DATUM **-A-** IS TOP SURFACE OF THE HOST BOARD.
- THESE HOLES ARE OPTIONAL WHEN THE REAR PINS ARE REMOVED.
- MATES WITH QSFP28 MSA COMPATIBLE TRANSCEIVER.
- DATE CODE (YYWWD) MARKED APPROXIMATELY AS SHOWN.
- NOTED DIMENSIONS ONLY APPLY TO CAGE ASSEMBLY WITH LIGHT PIPE.
- PRELIMINARY PART - NOT RELEASED FOR PRODUCTION.

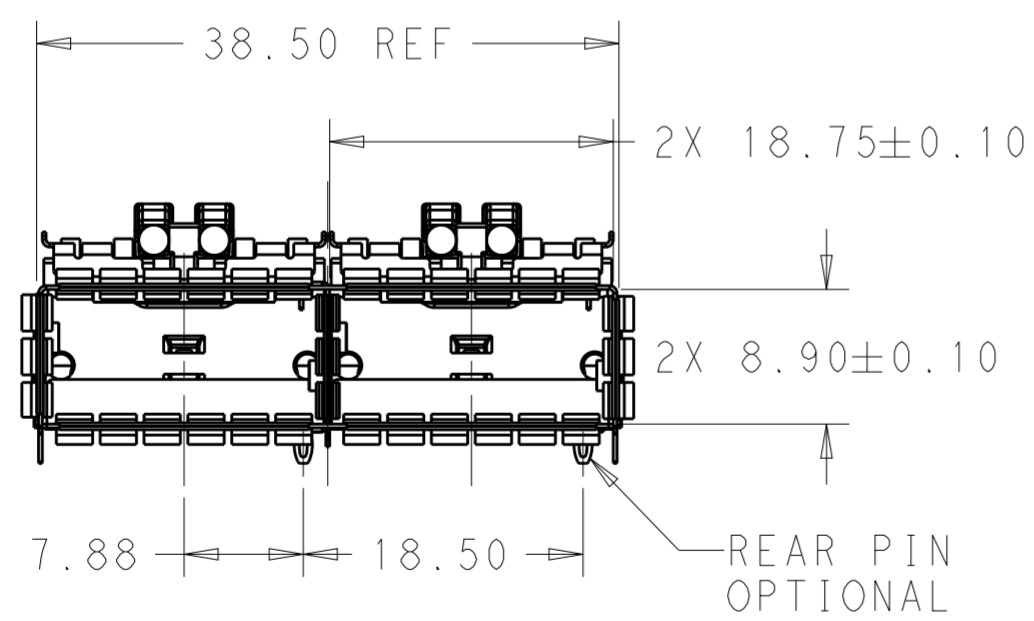

SCALE 2:1

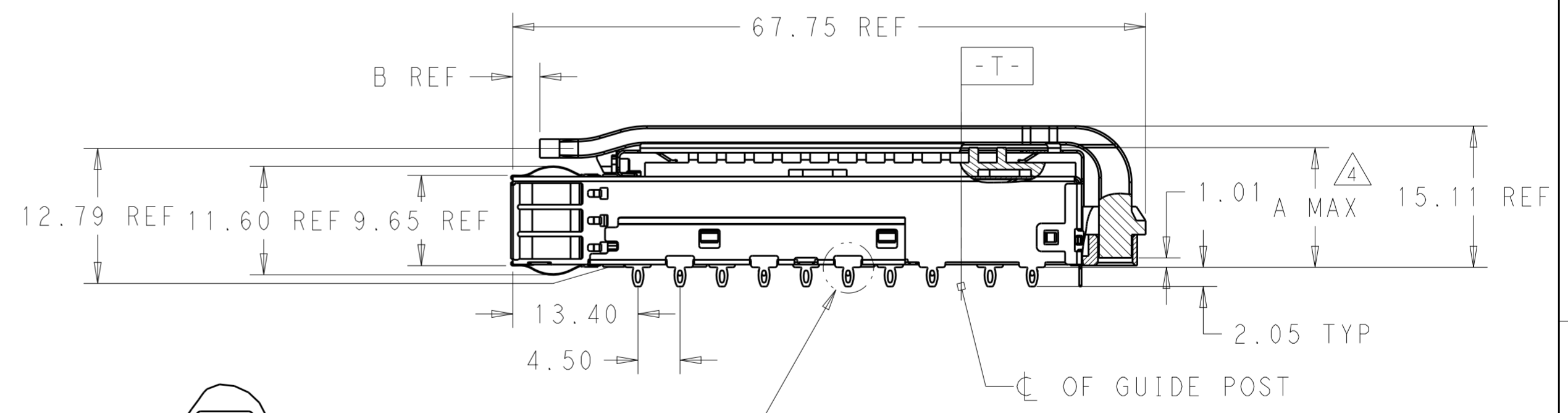

SECTION A-A
 D-D

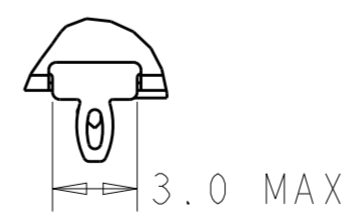

DETAIL E
 SCALE 4:1

THIS DRAWING IS A CONTROLLED DOCUMENT.		DWN BING LIU 16SEP2014	STE TE Connectivity	
		CHK JASON YANG 16SEP2014		
DIMENSIONS: mm	TOLERANCES UNLESS OTHERWISE SPECIFIED: 0 PLC ± 1 PLC ±0.25 2 PLC ±0.2 3 PLC ± 4 PLC ± ANGLES ± FINISH	APVD -	NAME RECEPTACLE CAGE ASSEMBLY 1X2, QSFP28, THRU BEZEL, SPRING WITH HEAT SINKS AND LIGHT PIPES	RESTRICTED TO
MATERIAL SEE NOTES	SEE NOTES	PRODUCT SPEC 108-19428 APPLICATION SPEC 114-32023 WEIGHT -	SIZE A200779	DRAWING NO C-2170808
		CUSTOMER DRAWING	SCALE 1:1	SHEET 1 OF 9 REV B

REVISIONS				
P	LTR	DESCRIPTION	DATE	APVD
-		SEE SHEET 1	-	-

HEAT SINK OPTION

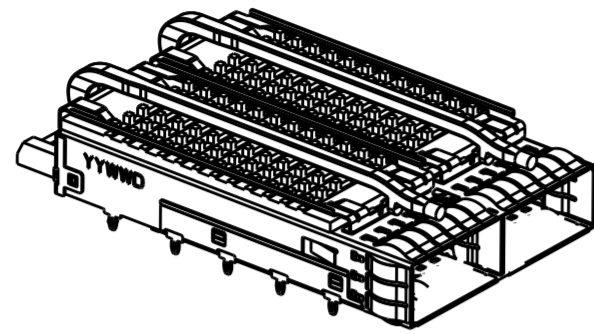

PCI HEAT SINK HEIGHT
SCALE 1:1

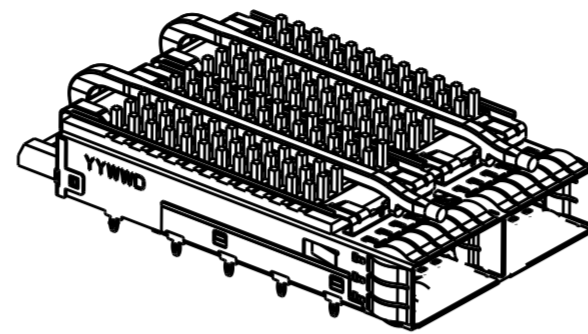

SAN HEAT SINK HEIGHT
SCALE 1:1

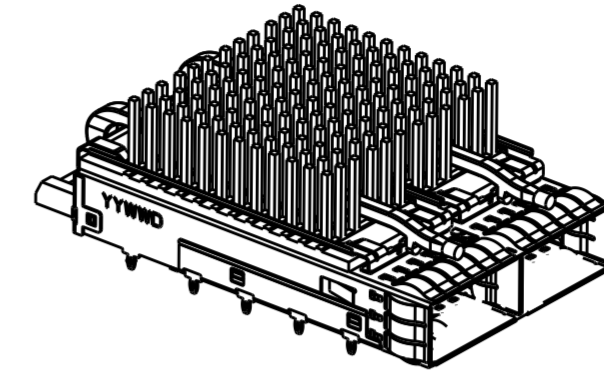

NETWORKING HEAT SINK HEIGHT
SCALE 1:1

LIGHT PIPE OPTION

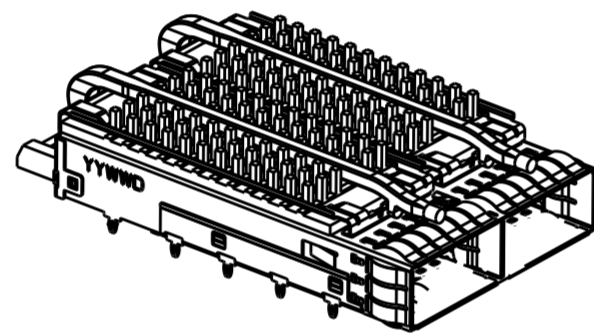

SINGLE LIGHT PIPE
SCALE 1:1

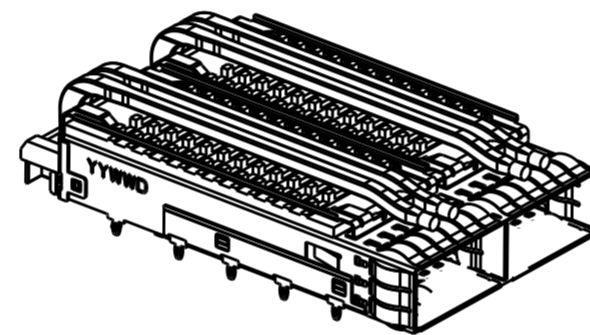

DUAL LIGHT PIPE
SCALE 1:1

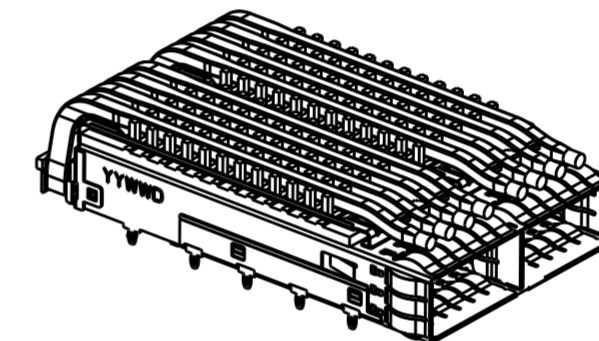

QUAD LIGHT PIPE
SCALE 1:1

OF REAR PIN OPTION

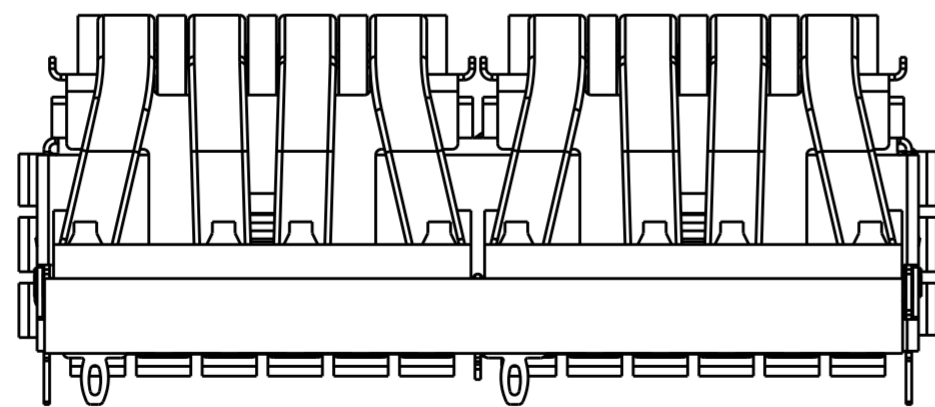

1 REAR PIN
SCALE 3:1

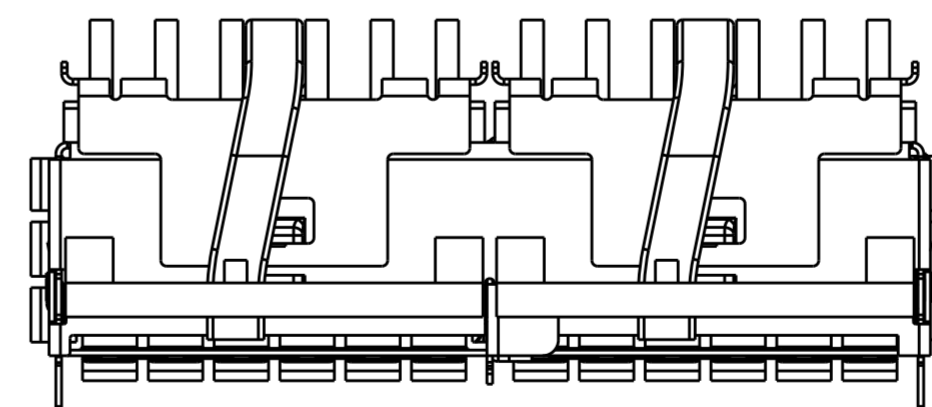

0 REAR PIN
SCALE 3:1

THIS DRAWING IS A CONTROLLED DOCUMENT.		DWN BING LIU 16SEP2014	TE Connectivity	
		CHK JASON YANG 16SEP2014		
DIMENSIONS: mm		APVD -		NAME RECEPTACLE CAGE ASSEMBLY 1X2, QSFP28, THRU BEZEL, SPRING WITH HEAT SINKS AND LIGHT PIPES
TOLERANCES UNLESS OTHERWISE SPECIFIED: 0 PLC ± 1 PLC ±0.25 2 PLC ±0.2 3 PLC ± 4 PLC ± ANGLES ± FINISH		PRODUCT SPEC 108-19428		SIZE 114-32023
MATERIAL SEE NOTES		APPLICATION SPEC 114-32023		RESTRICTED TO -
		WEIGHT -		SCALE 1:1
		CUSTOMER DRAWING		SHEET 2 OF 9 REV B

THIS DRAWING IS UNPUBLISHED. RELEASED FOR PUBLICATION 20
 © COPYRIGHT 20 BY - ALL RIGHTS RESERVED.

REVISIONS					
P	LTR	DESCRIPTION	DATE	DWN	APVD
-		SEE SHEET 1	-	-	-

0	3.4	16.0	SAN	COATED QUAD LP	5-2170808-5
1	2.9	18.4	CUSTOMIZED	QUAD LP	4-2170808-7
0	2.9	23.0	NETWORKING	QUAD LP	4-2170808-6
0	2.9	16.0	SAN	QUAD LP	4-2170808-5
0	2.9	13.7	PCI	QUAD LP	4-2170808-4
1	2.9	23.0	NETWORKING	QUAD LP	4-2170808-3
1	2.9	16.0	SAN	QUAD LP	4-2170808-2
1	2.9	13.7	PCI	QUAD LP	4-2170808-1
1	4.5	13.7	PCI	SHORTER, QUAD LP	4-2170808-0
0	2.9	23.0	NETWORKING	DUAL LP	2-2170808-6
0	2.9	16.0	SAN	DUAL LP	2-2170808-5
0	2.9	13.7	PCI	DUAL LP	2-2170808-4
1	2.9	23.0	NETWORKING	DUAL LP	2-2170808-3
1	2.9	16.0	SAN	DUAL LP	2-2170808-2
1	2.9	13.7	PCI	DUAL LP	2-2170808-1
0	2.9	23.0	NETWORKING	SINGLE LP	2170808-6
0	2.9	16.0	SAN	SINGLE LP	2170808-5
0	2.9	13.7	PCI	SINGLE LP	2170808-4
1	2.9	23.0	NETWORKING	SINGLE LP	2170808-3
1	2.9	16.0	SAN	SINGLE LP	2170808-2
1	2.9	13.7	PCI	SINGLE LP	2170808-1
# OF REAR PIN	DIM B (LP EXTRUDE)	DIM A (PRODUCT HEIGHT)	APPLICATION	LIGHT PIPE OPTION	PART NUMBER

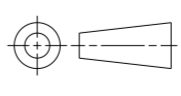

THIS DRAWING IS A CONTROLLED DOCUMENT.		DWN BING LIU 16SEP2014	 TE Connectivity	
		CHK JASON YANG 16SEP2014		
DIMENSIONS: mm	TOLERANCES UNLESS OTHERWISE SPECIFIED:	APVD -	NAME RECEPTACLE CAGE ASSEMBLY 1X2, QSFP28, THRU BEZEL, SPRING WITH HEAT SINKS AND LIGHT PIPES	
	0 PLC ± 1 PLC ±0.25 2 PLC ±0.2 3 PLC ± 4 PLC ±	PRODUCT SPEC 108-19428	SIZE A200779	CAGE CODE C-2170808
	ANGLES ± FINISH	APPLICATION SPEC 114-32023	DRAWING NO	RESTRICTED TO
MATERIAL SEE NOTES	SEE NOTES	WEIGHT -	SCALE 1:1 SHEET 3 OF 9 REV B	
		CUSTOMER DRAWING		

THIS DRAWING IS UNPUBLISHED. RELEASED FOR PUBLICATION 20
 © COPYRIGHT 20 BY - ALL RIGHTS RESERVED.

REVISIONS				
P	LTR	DESCRIPTION	DATE	APVD
-	-	SEE SHEET 1	-	-

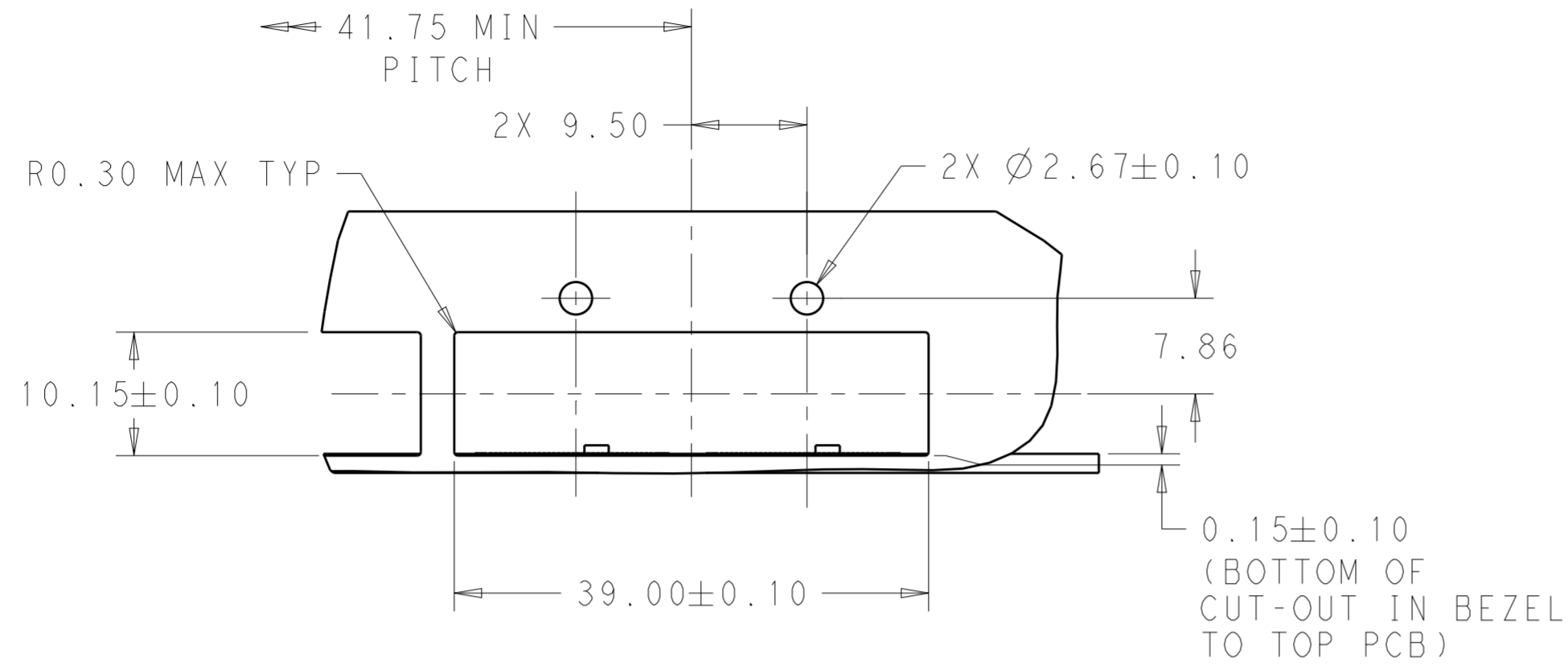

CAGE ASSEMBLY IS OMITED

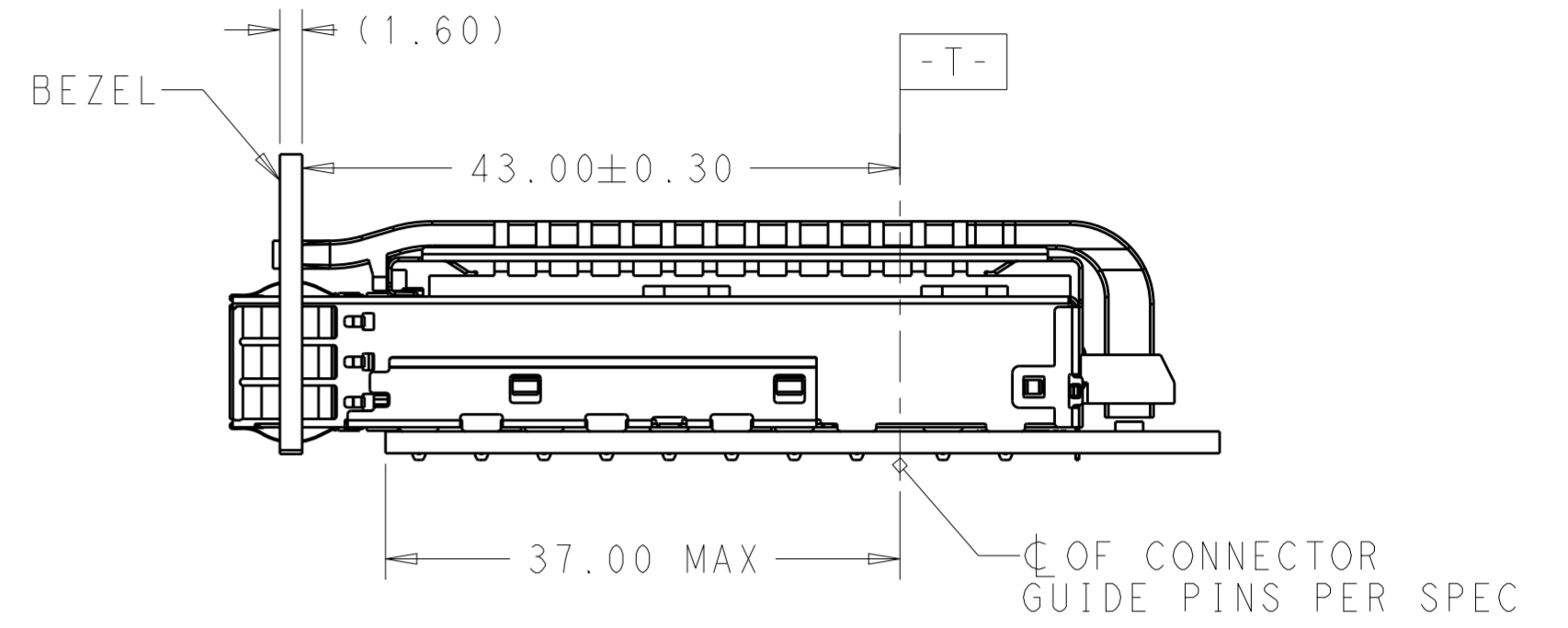

SINGLE SIDE MOUNTING
SCALE 2:1

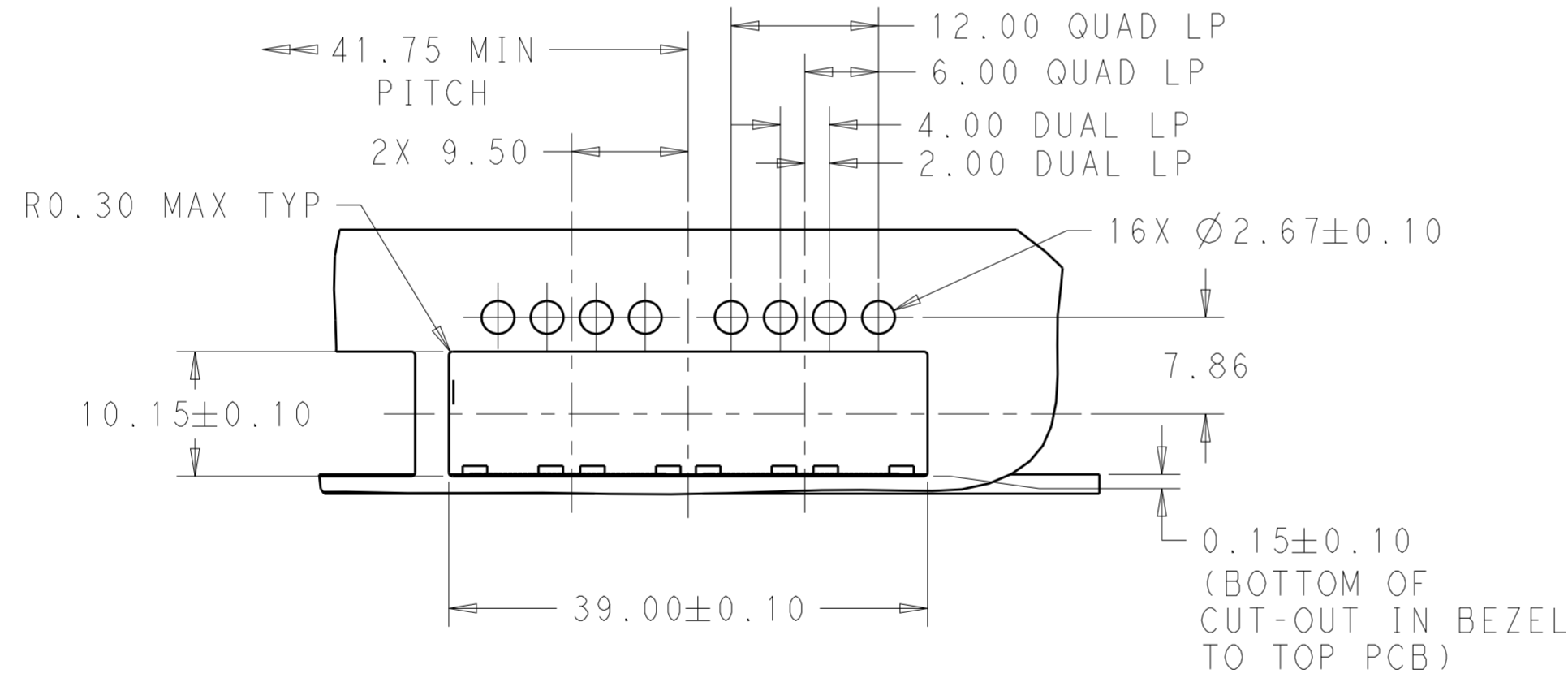

CAGE ASSEMBLY IS OMITED

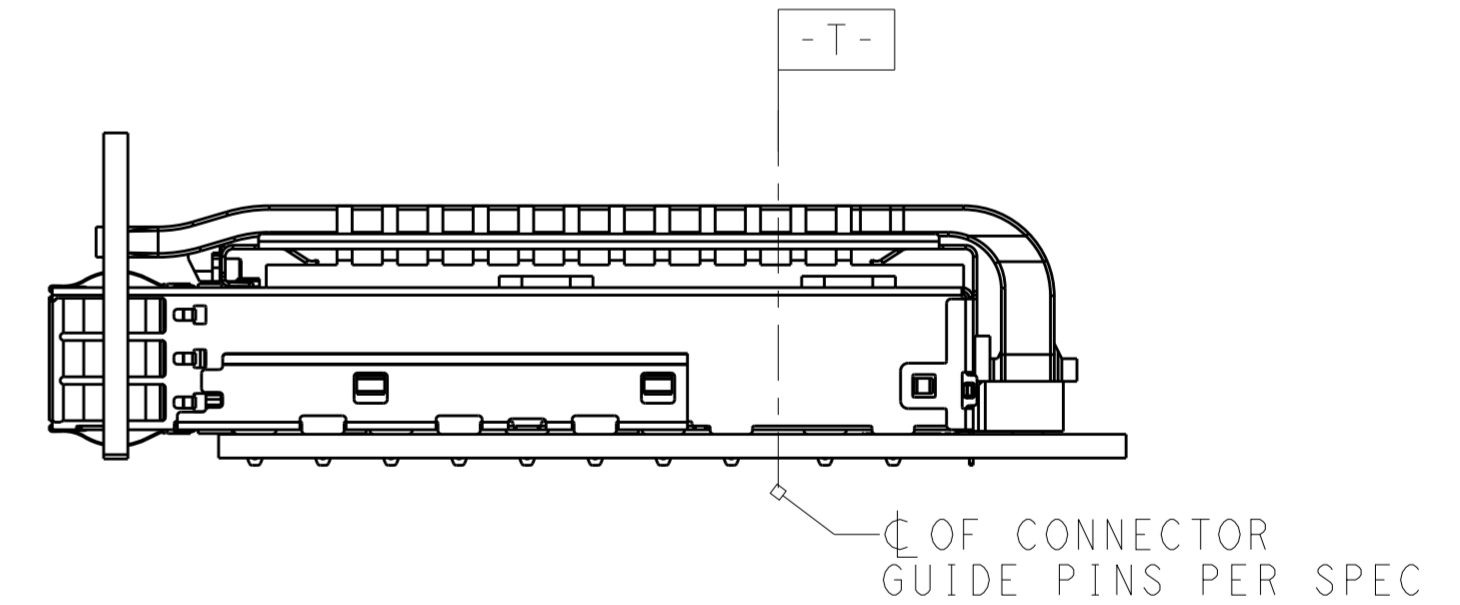

SINGLE SIDE MOUNTING
SCALE 2:1

THIS DRAWING IS A CONTROLLED DOCUMENT.		DWN BING LIU 16SEP2014	TE Connectivity	
		CHK JASON YANG 16SEP2014		
DIMENSIONS:	TOLERANCES UNLESS OTHERWISE SPECIFIED:	APVD	NAME	
mm	0 PLC ± 1 PLC ±0.25 2 PLC ±0.2 3 PLC ± 4 PLC ± ANGLES ± FINISH	-	RECEPTACLE CAGE ASSEMBLY 1X2, QSFP28, THRU BEZEL, SPRING WITH HEAT SINKS AND LIGHT PIPES	
MATERIAL	SEE NOTES	PRODUCT SPEC 108-19428	SIZE	RESTRICTED TO
-	SEE NOTES	APPLICATION SPEC 114-32023	A200779	-
		WEIGHT	C-2170808	
		CUSTOMER DRAWING	SCALE 1:1	SHEET 4 OF 9 REV B

THIS DRAWING IS UNPUBLISHED. RELEASED FOR PUBLICATION 20
 © COPYRIGHT 20 BY - ALL RIGHTS RESERVED.

REVISIONS				
P	LTR	DESCRIPTION	DATE	APVD
-	-	SEE SHEET 1	-	-

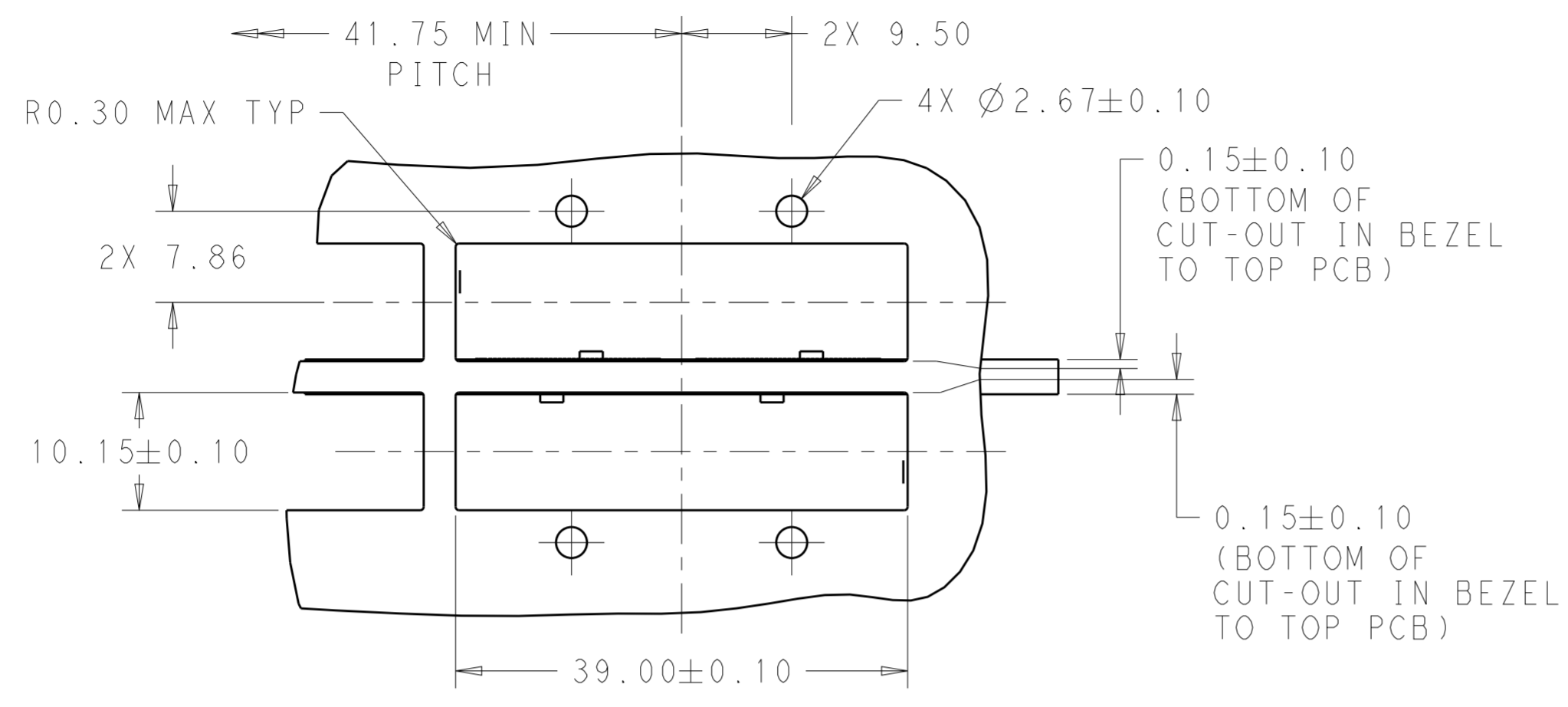

CAGE ASSEMBLY IS OMITED

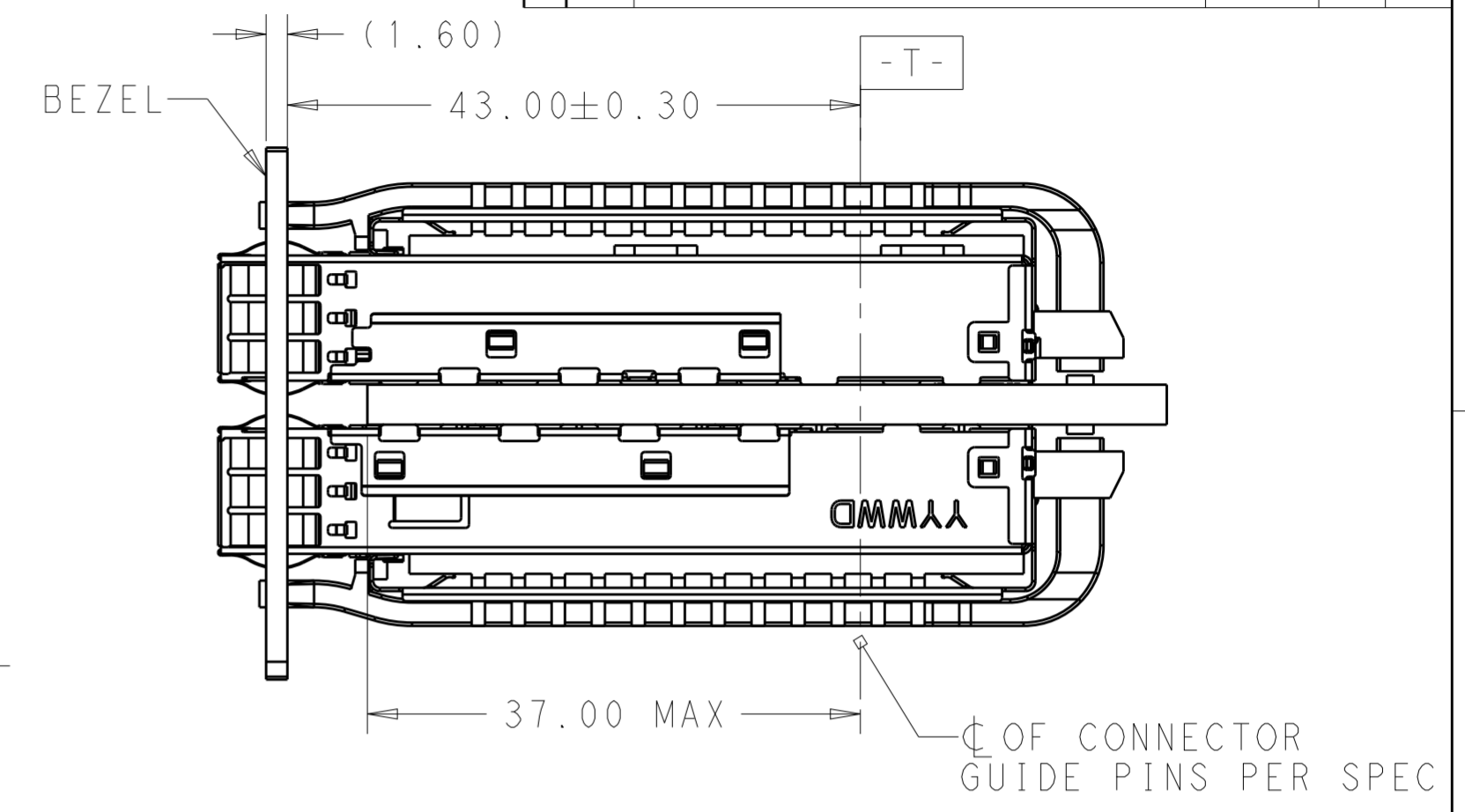

BELLY TO BELLY MOUNTING
SCALE 2:1

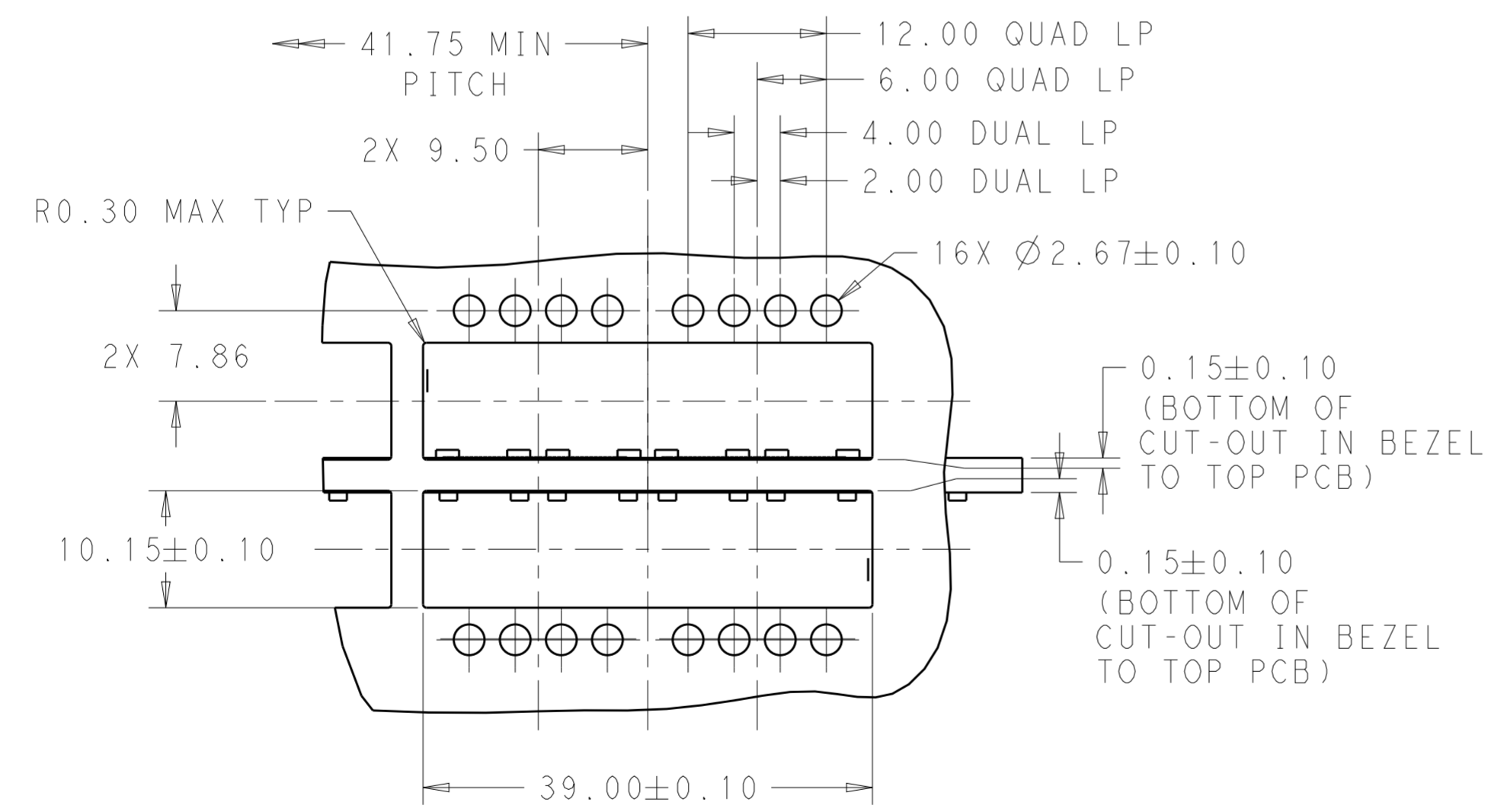

CAGE ASSEMBLY IS OMITED

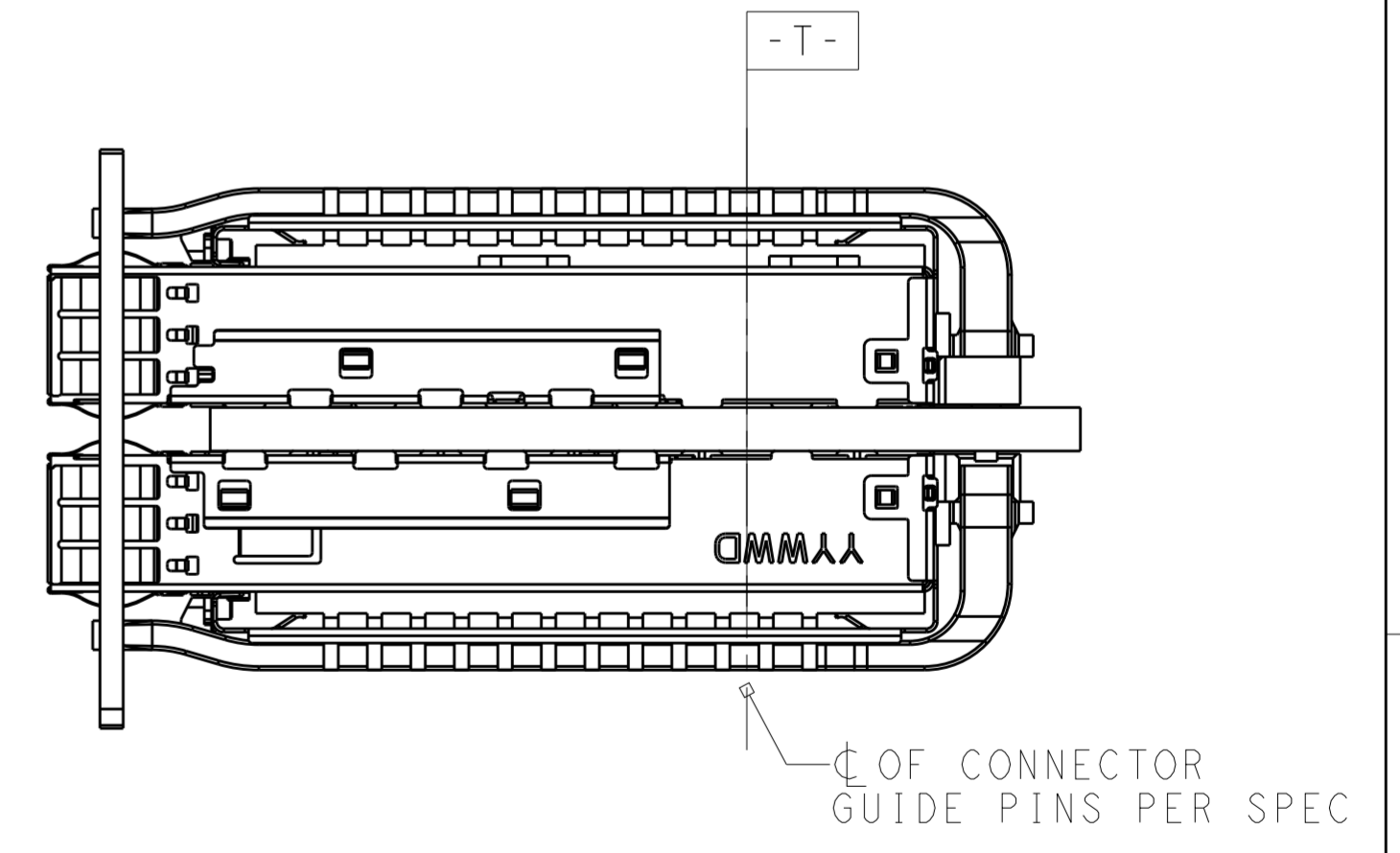

BELLY TO BELLY MOUNTING
SCALE 2:1

THIS DRAWING IS A CONTROLLED DOCUMENT.		DWN BING LIU 16SEP2014	TE Connectivity	
		CHK JASON YANG 16SEP2014		
DIMENSIONS: mm		TOLERANCES UNLESS OTHERWISE SPECIFIED:		NAME RECEPTACLE CAGE ASSEMBLY 1X2, QSFP28, THRU BEZEL, SPRING WITH HEAT SINKS AND LIGHT PIPES
		0 PLC ±	1 PLC ±0.25	PRODUCT SPEC 108-19428
MATERIAL SEE NOTES		2 PLC ±0.2	3 PLC ±	APPLICATION SPEC 114-32023
		4 PLC ±	ANGLES ±	SIZE A200779
		FINISH		CAGE CODE C-2170808
				DRAWING NO -
				RESTRICTED TO -
				SCALE 1:1 SHEET 5 OF 9 REV B
				CUSTOMER DRAWING

THIS DRAWING IS UNPUBLISHED. RELEASED FOR PUBLICATION 20
 © COPYRIGHT 20 BY - ALL RIGHTS RESERVED.

REVISIONS				
P	LTR	DESCRIPTION	DATE	APVD
-	-	SEE SHEET 1	-	-

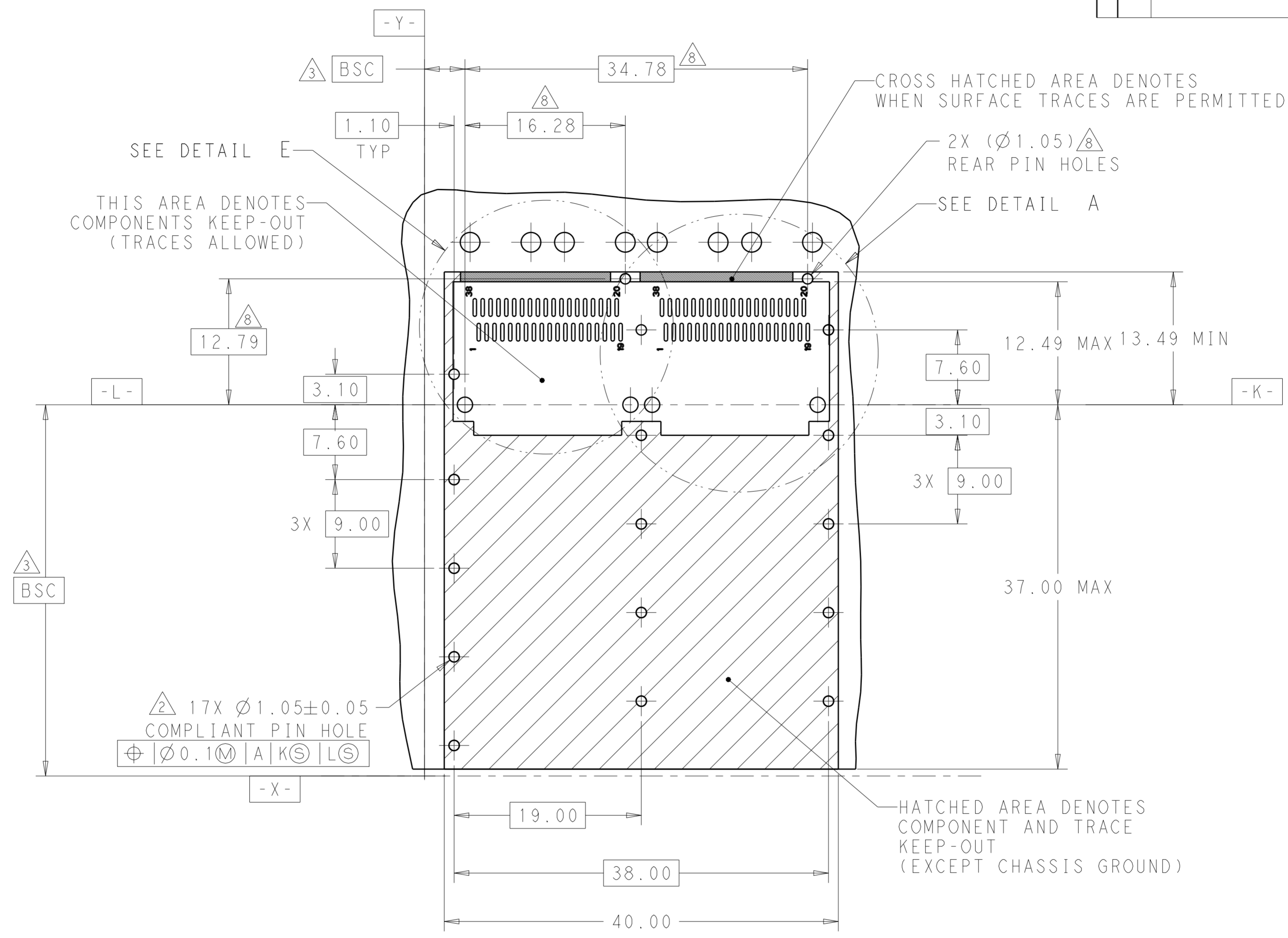

THIS AREA DENOTES COMPONENTS KEEP-OUT (TRACES ALLOWED)

CROSS HATCHED AREA DENOTES WHEN SURFACE TRACES ARE PERMITTED

2X (Ø1.05) REAR PIN HOLES

SEE DETAIL A

17X Ø1.05±0.05 COMPLIANT PIN HOLE
 Ø0.1(M) | A | K(S) | L(S)

HATCHED AREA DENOTES COMPONENT AND TRACE KEEP-OUT (EXCEPT CHASSIS GROUND)

RECOMMENDED PCB LAYOUT
 SINGLE TYPE
 PCB TOLERANCE: ±0.05
 SCALE 3:1

THIS DRAWING IS A CONTROLLED DOCUMENT.		DWN BING LIU 16SEP2014	TE Connectivity	
		CHK JASON YANG 16SEP2014		
DIMENSIONS: mm		APVD -	NAME RECEPTACLE CAGE ASSEMBLY	
TOLERANCES UNLESS OTHERWISE SPECIFIED:		PRODUCT SPEC 108-19428	1X2, QSFP28, THRU BEZEL, SPRING WITH HEAT SINKS AND LIGHT PIPES	
0 PLC ±-	1 PLC ±0.25	APPLICATION SPEC 114-32023	SIZE A2	CAGE CODE 00779
2 PLC ±0.2	3 PLC ±-	WEIGHT -	DRAWING NO C-2170808	RESTRICTED TO -
4 PLC ±-	ANGLES ±-	CUSTOMER DRAWING	SCALE 1:1	SHEET 6 OF 9
MATERIAL SEE NOTES	FINISH SEE NOTES			REV B

REVISIONS				
P	LTR	DESCRIPTION	DATE	APVD
-	-	SEE SHEET 1	-	-

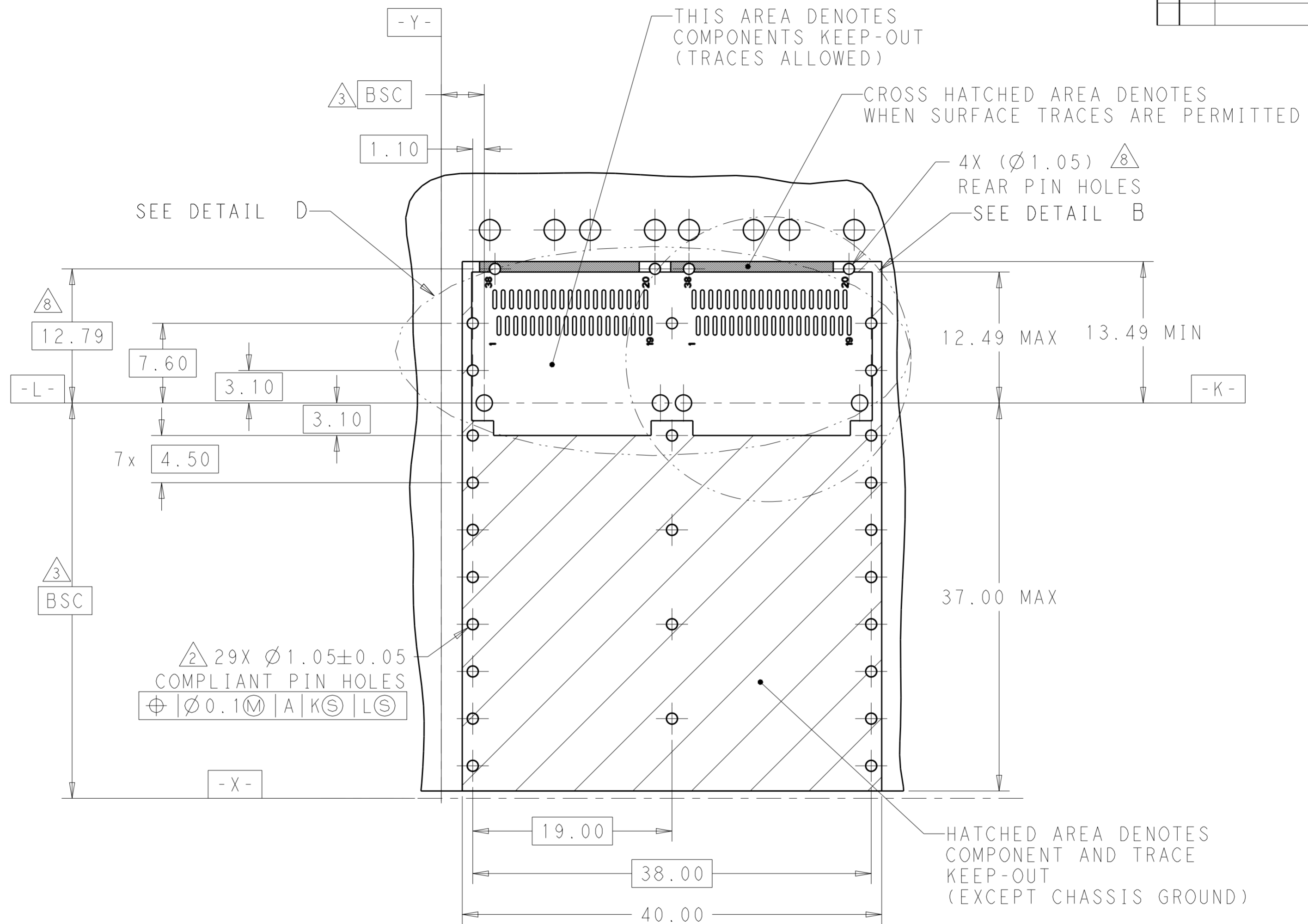

2 29X Ø1.05±0.05
 COMPLIANT PIN HOLES
 Ø | Ø0.1M | A | K | L | S

RECOMMENDED PCB LAYOUT
 BELLY TO BELLY TYPE
 PCB TOLERANCE: ±0.05
 SCALE 3:1

THIS DRAWING IS A CONTROLLED DOCUMENT.		DWN BING LIU 16SEP2014	 TE Connectivity		
		CHK JASON YANG 16SEP2014			
DIMENSIONS: mm		TOLERANCES UNLESS OTHERWISE SPECIFIED: 0 PLC ± 1 PLC ±0.25 2 PLC ±0.2 3 PLC ± 4 PLC ± ANGLES ± FINISH ±		NAME RECEPTACLE CAGE ASSEMBLY 1X2, QSFP28, THRU BEZEL, SPRING WITH HEAT SINKS AND LIGHT PIPES	
MATERIAL SEE NOTES		PRODUCT SPEC 108-19428 APPLICATION SPEC 114-32023		SIZE A200779	
		WEIGHT -		DRAWING NO C-2170808	
		CUSTOMER DRAWING		RESTRICTED TO -	
		SCALE 1:1		SHEET 7 OF 9	
				REV B	

THIS DRAWING IS UNPUBLISHED. RELEASED FOR PUBLICATION 20
 © COPYRIGHT 20 BY - ALL RIGHTS RESERVED.

REVISIONS				
P	LTR	DESCRIPTION	DATE	APVD
-	-	SEE SHEET 1	-	-

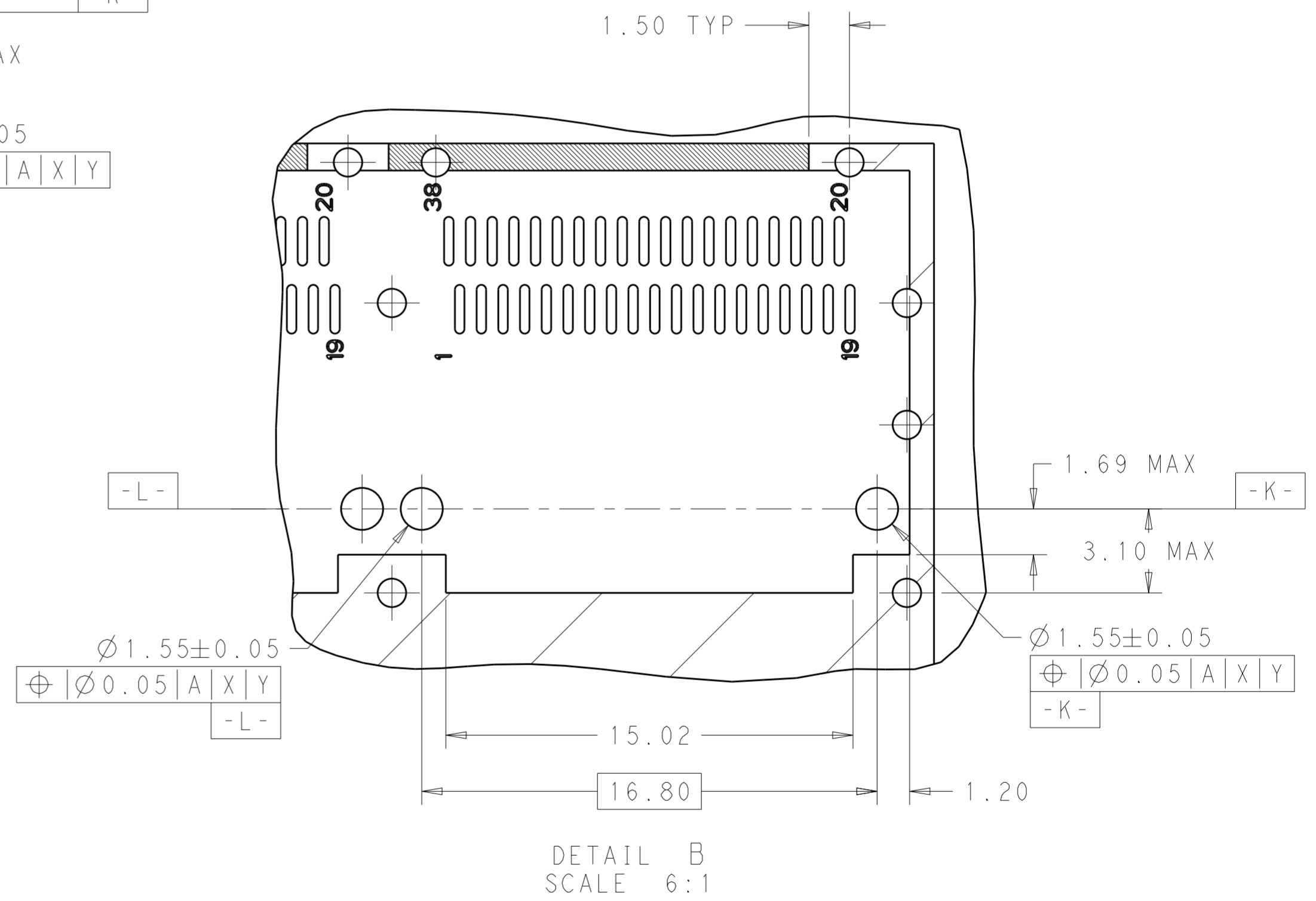
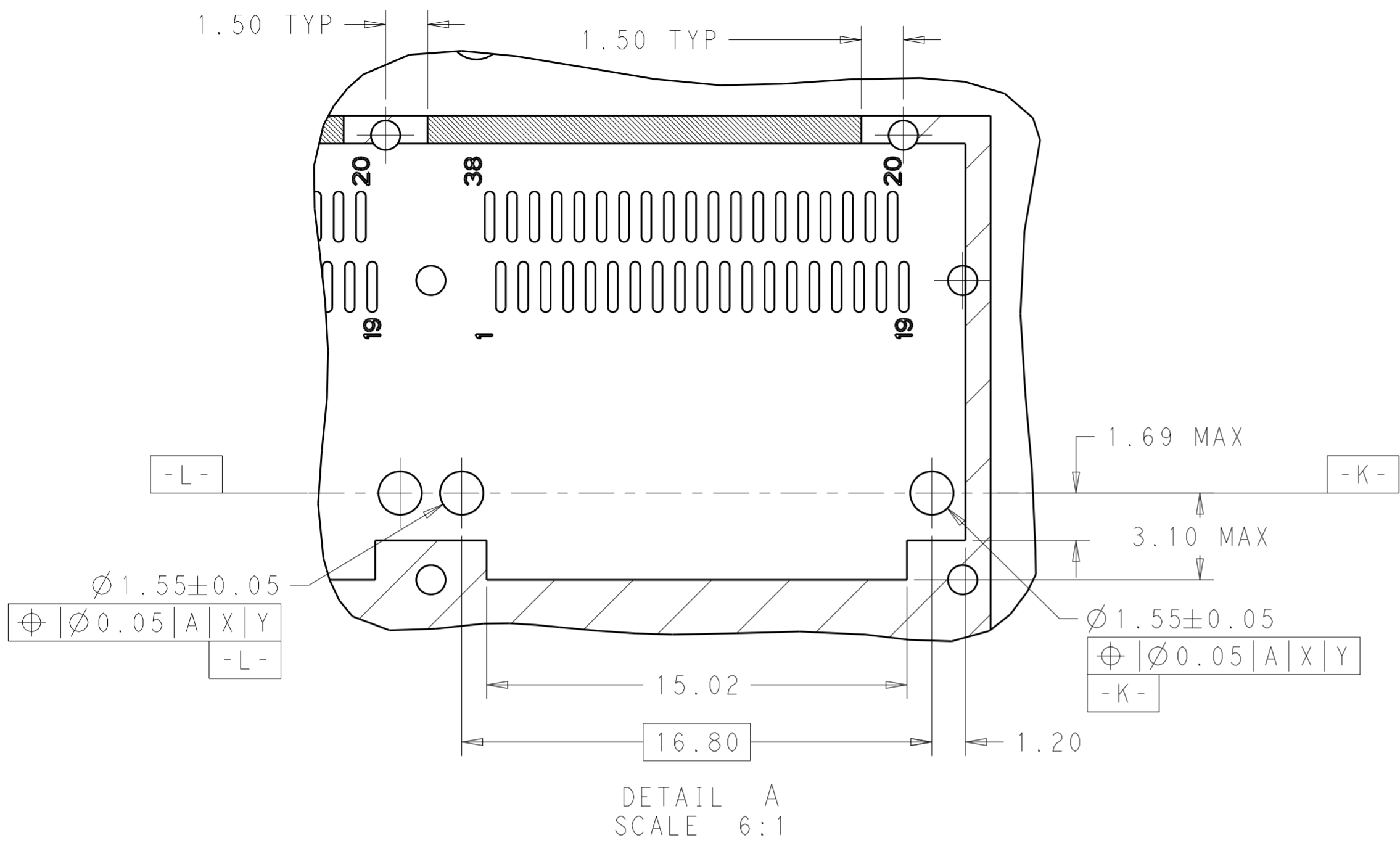

THIS DRAWING IS A CONTROLLED DOCUMENT.		DWN BING LIU 16SEP2014	STE TE Connectivity	
		CHK JASON YANG 16SEP2014		
DIMENSIONS: mm	TOLERANCES UNLESS OTHERWISE SPECIFIED:	APVD -	NAME RECEPTACLE CAGE ASSEMBLY 1X2, QSFP28, THRU BEZEL, SPRING WITH HEAT SINKS AND LIGHT PIPES	
0 PLC ±	1 PLC ±0.25	PRODUCT SPEC 108-19428	SIZE A2	CAGE CODE 00779
2 PLC ±0.2	3 PLC ±	APPLICATION SPEC 114-32023	DRAWING NO C-2170808	RESTRICTED TO -
4 PLC ±	ANGLES ±	WEIGHT -	SCALE 1:1 SHEET 8 OF 9 REV B	
MATERIAL SEE NOTES	FINISH SEE NOTES	CUSTOMER DRAWING		

THIS DRAWING IS UNPUBLISHED. RELEASED FOR PUBLICATION 20
 © COPYRIGHT 20 BY - ALL RIGHTS RESERVED.

REVISIONS				
P	LTR	DESCRIPTION	DATE	APVD
-	-	SEE SHEET 1	-	-

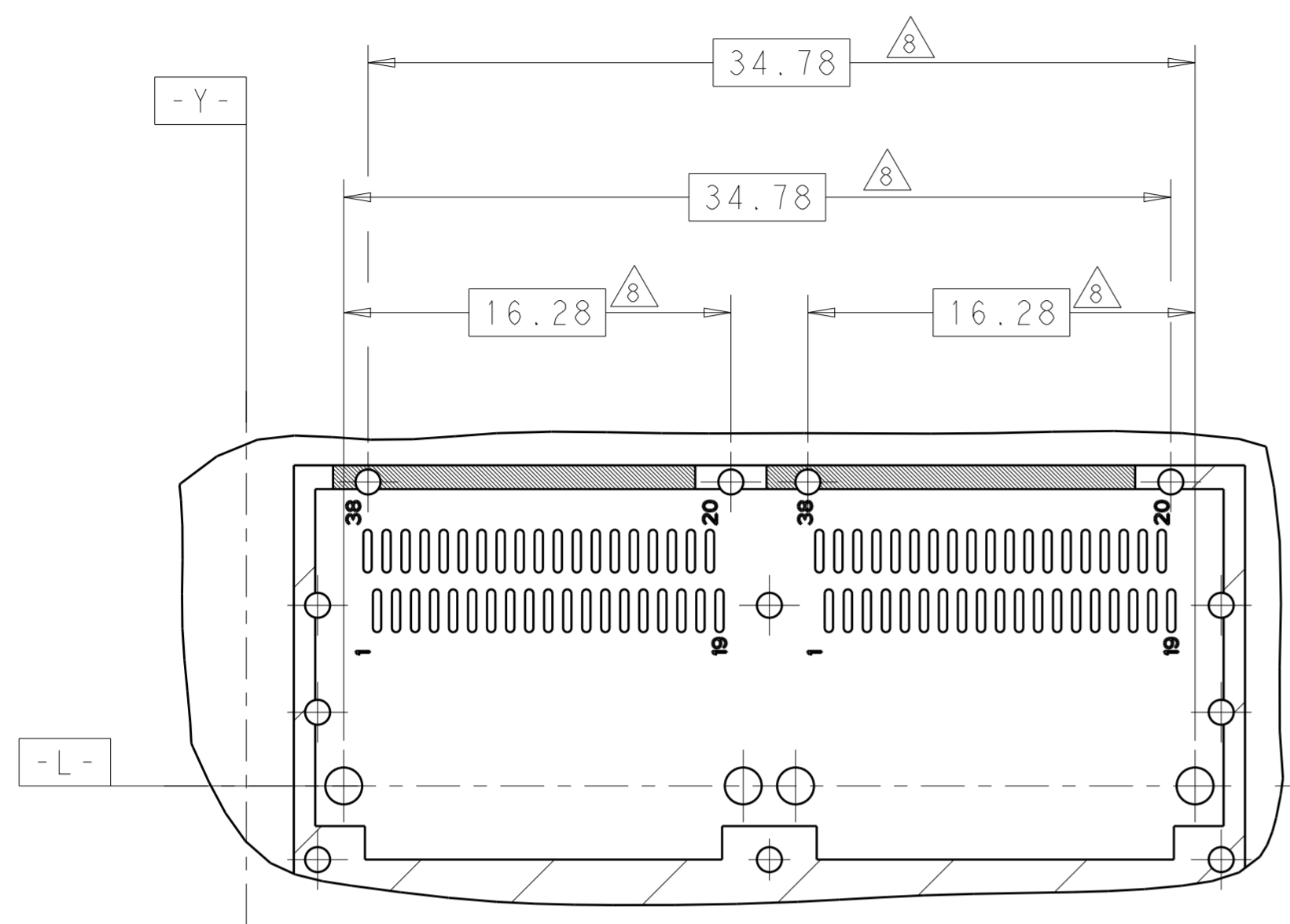

DETAIL D
SCALE 4:1

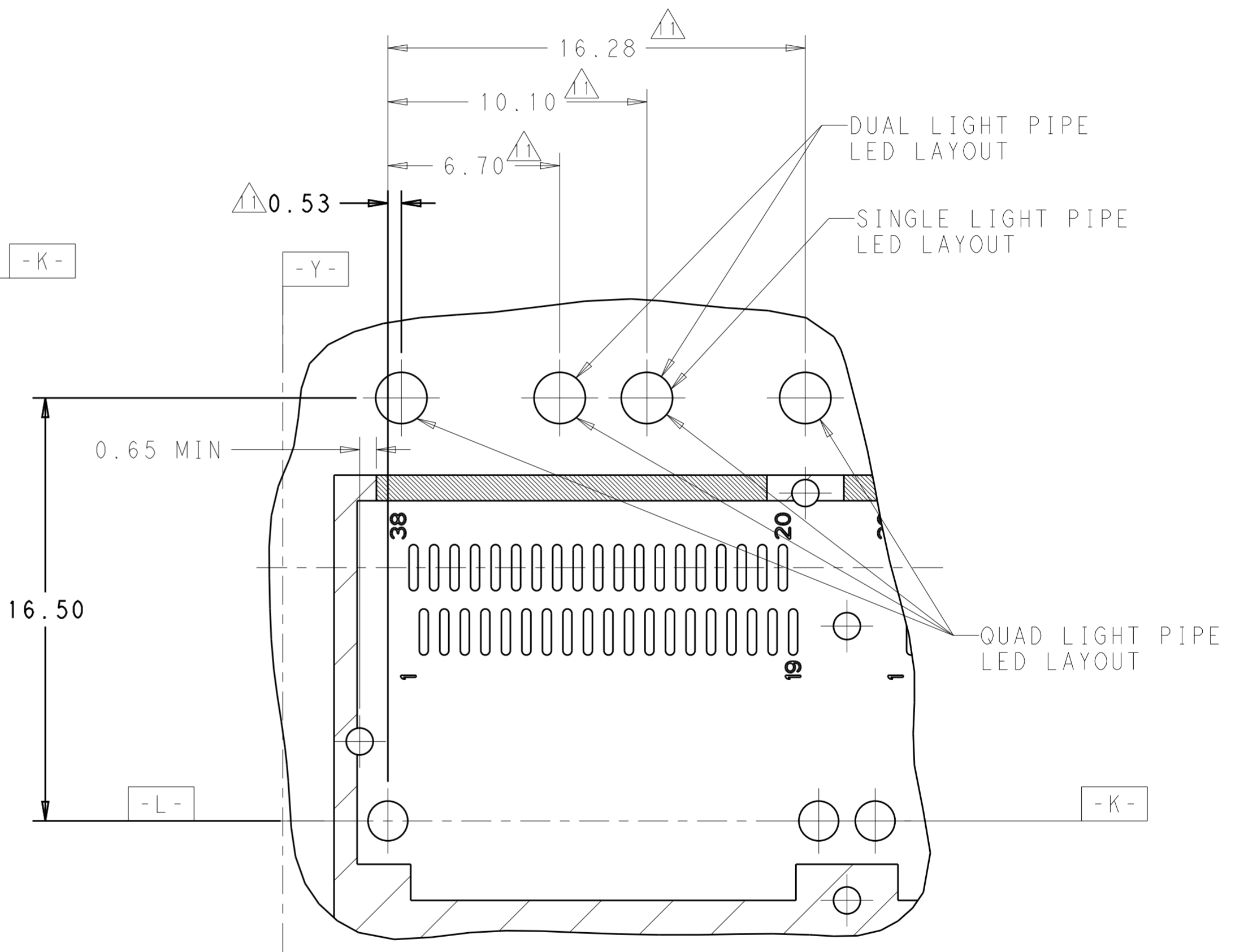

DETAIL E
SCALE 6:1

THIS DRAWING IS A CONTROLLED DOCUMENT.		DWN BING LIU 16SEP2014	STE TE Connectivity	
		CHK JASON YANG 16SEP2014		
DIMENSIONS: mm	TOLERANCES UNLESS OTHERWISE SPECIFIED:	APVD -	NAME RECEPTACLE CAGE ASSEMBLY 1X2, QSFP28, THRU BEZEL, SPRING WITH HEAT SINKS AND LIGHT PIPES	RESTRICTED TO
	0 PLC ± 1 PLC ±0.25 2 PLC ±0.2 3 PLC ± 4 PLC ± ANGLES ± FINISH	PRODUCT SPEC 108-19428	SIZE A200779	DRAWING NO C-2170808
MATERIAL SEE NOTES	SEE NOTES	APPLICATION SPEC 114-32023	SCALE 1:1	SHEET 9 OF 9
		WEIGHT -	CUSTOMER DRAWING	REV B

Mouser Electronics

Authorized Distributor

Click to View Pricing, Inventory, Delivery & Lifecycle Information:

[TE Connectivity:](#)

[4-2170808-2](#)