

REVISIONS					
P	LTR	DESCRIPTION	DATE	DRN	APP'D
P3		PART STATUS UPDATED IN PART LIST TABLE	08FEB2018	SD	PS

- 1 STANDOFFS: UP TO 9 POS--(2 REQD) ON THE OUTSIDE ENDS OF THE HOUSING  
10 TO 19 POS--(3 REQD) TWO ON THE OUTSIDE ENDS AND ONE CENTERED ON THE HOUSING  
19 POS AND LARGER--(4 REQD) TWO ON THE OUTSIDE ENDS AND TWO SPACED EVENLY WITHIN THE REMAINING LENGTH OF THE HOUSING
- 2 POINT OF MEASUREMENT FOR PLATING THICKNESS
- 3 FOR 3 POS (3--4 ONLY) ONE SLOT, 5.46[.215] WIDE.
- 4 RECESSED DATE CODE
- 5 HOUSING: FLAME RETARDANT THERMOPLASTIC, COLOR - BLACK.  
POSTS: BRASS.
- 6 0.00038[.000015] GOLD ON THE CONTACT AREA,  
0.00254[.000100]-0.00508[.000200] MATTE TIN-LEAD ON THE SOLDER TAIL  
ALL OVER 0.00127[.000050] NICKEL.
- 7 0.00038[.000015] GOLD ON THE CONTACT AREA,  
0.00254[.000100]-0.00508[.000200] MATTE TIN ON THE SOLDER TAIL  
ALL OVER 0.00127[.000050] NICKEL.
- 8 OBSOLETE PARTS: OBSOLETE CIS STREAMLINING PER D.RENAUD/D.SINISI

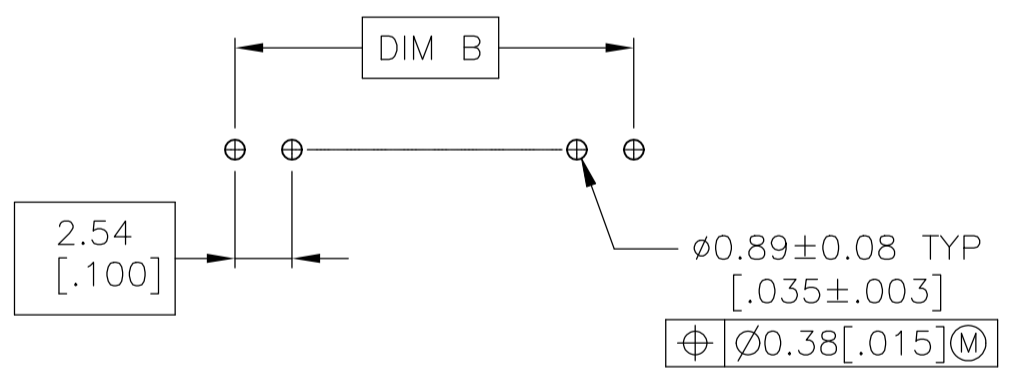
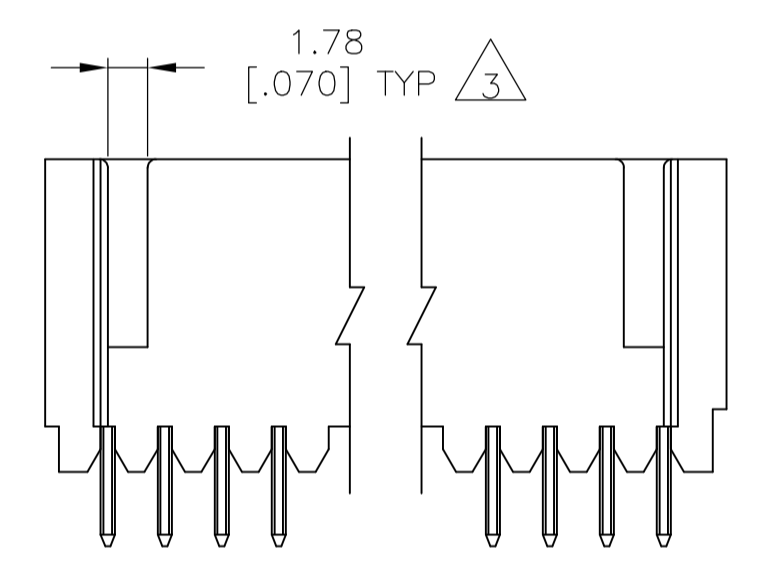
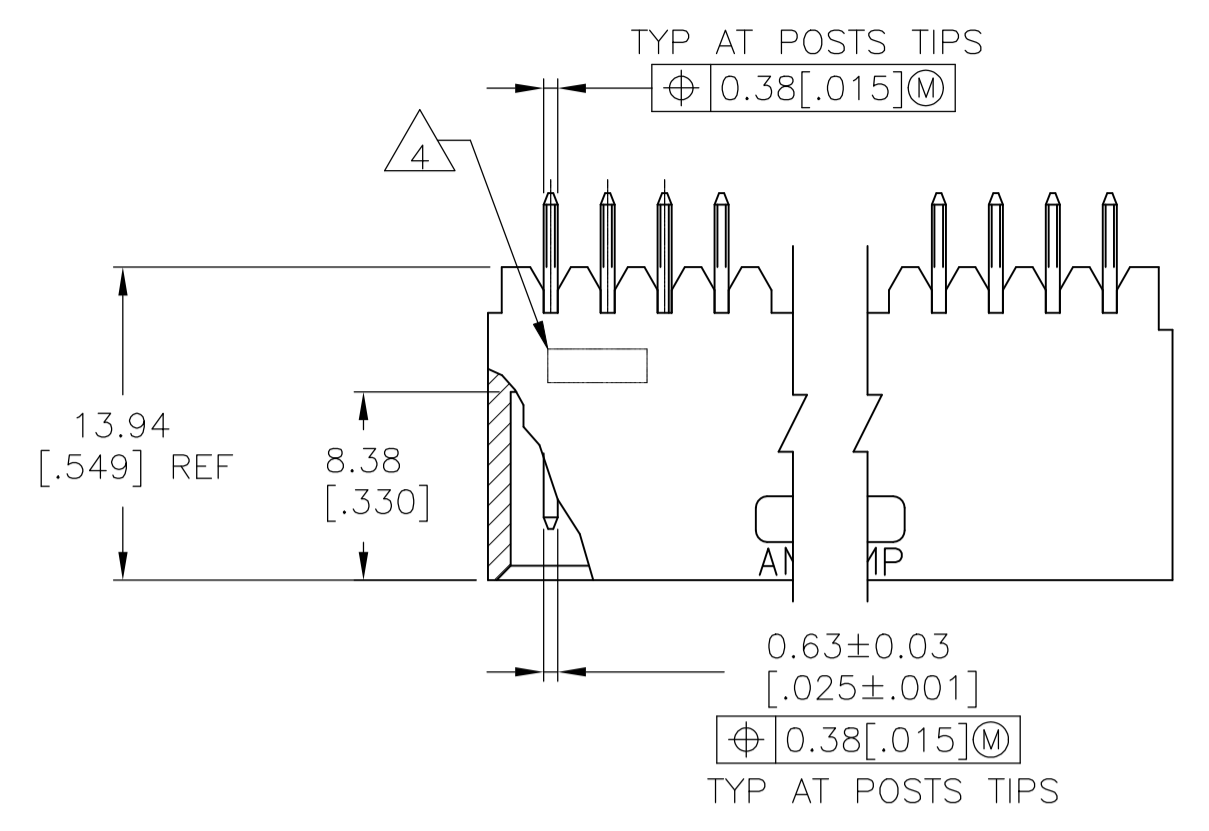

RECOMMENDED HOLE LAYOUT

3	6	8.64 [.340]	5.08 [.200]	2	3	8-102202-4
OBSOLETE	10.67 [.420]	64.52 [2.540]	60.96 [2.400]	24	25	7-102202-2
OBSOLETE	66.55 [2.620]	61.98 [2.440]	58.42 [2.300]	23	24	7-102202-1
OBSOLETE	61.47 [2.420]	59.44 [2.340]	55.88 [2.200]	22	23	7-102202-0
OBSOLETE	58.93 [2.320]	56.90 [2.240]	53.34 [2.100]	21	22	6-102202-9
OBSOLETE	56.39 [2.220]	54.36 [2.140]	50.80 [2.000]	20	21	6-102202-8
OBSOLETE	53.85 [2.120]	51.82 [2.040]	48.26 [1.900]	19	20	6-102202-7
OBSOLETE	51.31 [2.020]	49.28 [1.940]	45.72 [1.800]	18	19	6-102202-6
	48.77 [1.920]	46.74 [1.840]	43.18 [1.700]	17	18	6-102202-5
	46.23 [1.820]	44.20 [1.740]	40.64 [1.600]	16	17	6-102202-4
	43.69 [1.720]	41.66 [1.640]	38.10 [1.500]	15	16	6-102202-3
	41.15 [1.620]	39.12 [1.540]	35.56 [1.400]	14	15	6-102202-2
	38.61 [1.520]	36.58 [1.440]	33.02 [1.300]	13	14	6-102202-1
	36.07 [1.420]	34.04 [1.340]	30.48 [1.200]	12	13	6-102202-0
	33.53 [1.320]	31.50 [1.240]	27.94 [1.100]	11	12	5-102202-9
	30.99 [1.220]	28.96 [1.140]	25.40 [1.000]	10	11	5-102202-8
	28.45 [1.120]	26.42 [1.040]	22.86 [900]	9	10	5-102202-7
	25.91 [1.020]	23.88 [940]	20.32 [800]	8	9	5-102202-6
	23.37 [920]	21.34 [840]	17.78 [700]	7	8	5-102202-5
	20.83 [820]	18.80 [740]	15.24 [600]	6	7	5-102202-4
	18.29 [720]	16.26 [640]	12.70 [500]	5	6	5-102202-3
	15.75 [620]	13.72 [540]	10.16 [400]	4	5	5-102202-2
	13.21 [520]	11.18 [440]	7.62 [300]	3	4	5-102202-1
	10.67 [.420]	8.64 [.340]	5.08 [.200]	2	3	3-102202-4
OBSOLETE	94.49 [3.720]	92.46 [3.640]	88.90 [3.500]	35	36	3-102202-3
OBSOLETE	91.95 [3.620]	89.92 [3.540]	86.36 [3.400]	34	35	3-102202-2
OBSOLETE	89.41 [3.520]	87.38 [3.440]	83.82 [3.300]	33	34	3-102202-1
OBSOLETE	86.87 [3.420]	84.84 [3.340]	81.28 [3.200]	32	33	3-102202-0
OBSOLETE	84.33 [3.320]	82.30 [3.240]	78.74 [3.100]	31	32	2-102202-9
OBSOLETE	81.79 [3.220]	79.76 [3.140]	76.20 [3.000]	30	31	2-102202-8
OBSOLETE	79.25 [3.120]	77.22 [3.040]	73.66 [2.900]	29	30	2-102202-7
OBSOLETE	76.71 [3.020]	74.68 [2.940]	71.12 [2.800]	28	29	2-102202-6
OBSOLETE	74.17 [2.920]	72.14 [2.840]	68.58 [2.700]	27	28	2-102202-5
OBSOLETE	71.63 [2.820]	69.60 [2.740]	66.04 [2.600]	26	27	2-102202-4
OBSOLETE	69.09 [2.720]	67.06 [2.640]	63.50 [2.500]	25	26	2-102202-3
OBSOLETE	66.55 [2.620]	64.52 [2.540]	60.96 [2.400]	24	25	2-102202-2
OBSOLETE	64.01 [2.520]	61.98 [2.440]	58.42 [2.300]	23	24	2-102202-1
OBSOLETE	61.47 [2.420]	59.44 [2.340]	55.88 [2.200]	22	23	2-102202-0
OBSOLETE	58.93 [2.320]	56.90 [2.240]	53.34 [2.100]	21	22	1-102202-9
OBSOLETE	56.39 [2.220]	54.36 [2.140]	50.80 [2.000]	20	21	1-102202-8
OBSOLETE	53.85 [2.120]	51.82 [2.040]	48.26 [1.900]	19	20	1-102202-7
OBSOLETE	51.31 [2.020]	49.28 [1.940]	45.72 [1.800]	18	19	1-102202-6
	48.77 [1.920]	46.74 [1.840]	43.18 [1.700]	17	18	1-102202-5
	46.23 [1.820]	44.20 [1.740]	40.64 [1.600]	16	17	1-102202-4
	43.69 [1.720]	41.66 [1.640]	38.10 [1.500]	15	16	1-102202-3
	41.15 [1.620]	39.12 [1.540]	35.56 [1.400]	14	15	1-102202-2
	38.61 [1.520]	36.58 [1.440]	33.02 [1.300]	13	14	1-102202-1
	36.07 [1.420]	34.04 [1.340]	30.48 [1.200]	12	13	1-102202-0
	33.53 [1.320]	31.50 [1.240]	27.94 [1.100]	11	12	102202-9
	30.99 [1.220]	28.96 [1.140]	25.40 [1.000]	10	11	102202-8
	28.45 [1.120]	26.42 [1.040]	22.86 [900]	9	10	102202-7
	25.91 [1.020]	23.88 [940]	20.32 [800]	8	9	102202-6
	23.37 [920]	21.34 [840]	17.78 [700]	7	8	102202-5
	20.83 [820]	18.80 [740]	15.24 [600]	6	7	102202-4
	18.29 [720]	16.26 [640]	12.70 [500]	5	6	102202-3
	15.75 [620]	13.72 [540]	10.16 [400]	4	5	102202-2
	13.21 [520]	11.18 [440]	7.62 [300]	3	4	102202-1
PLATING	D	C	B	A	NO OF POSN	PART NUMBER

SUPERSEDED BY 6-102202-4

THIS DRAWING IS A CONTROLLED DOCUMENT. DRN: F. BRANDBERG, 04NOV97. DWG: -.

DIMENSIONS: mm [INCHES]. TOLERANCES UNLESS OTHERWISE SPECIFIED: 0 PLC ±, 1 PLC ±, 2 PLC ±, 3 PLC ± 0.38 [015], 4 PLC ±, ANGLES ±.

MATERIAL: 5. FINISH: SEE TABLE. WEIGHT: -. CUSTOMER DRAWING.

APVD: S. SHUJEE, 04NOV97. NAME: ASSEMBLY, MOD II, HEADER, SINGLE ROW. PRODUCT SPEC: .100 C/L. VERTICAL, WITH .025 SQUARE POSTS. APPLICATION SPEC: -. SIZE: A1. CAGE CODE: 00779. DRAWING NO: 102202. RESTRICTED TO: -. SCALE: 3:1. SHEET: 1 OF 1. REV: P3.

STE TE Connectivity

# Mouser Electronics

Authorized Distributor

Click to View Pricing, Inventory, Delivery & Lifecycle Information:

[TE Connectivity:](#)

[102202-8](#)