

| ATLANTIC VERSION TERMINATOR INTERFACE ADAPTER | PART NUMBER | REVISION | DESCRIPTION | FEED TYPE | CONVERT TO | PART NUMBERS REQUIRED | | | | | |
|---|-------------|--------------------------|--------------------------|-------------------|-------------------|-----------------------|-----------|-------------|-----------|-----------|------------------------|
| | 2266394-1 | A | FINE CRIMP HEIGHT ADJUST | MECHANICAL | PNEUMATIC FEED | 2119950-1 | 1338685-1 | 5-18022-5 | 2119641-1 | 2119799-1 | 2063440-1 |
| | 2266394-2 | A | FINE CRIMP HEIGHT ADJUST | PNEUMATIC | SERVO LATCH PLATE | 2119951-1 | - | 8-2266394-5 | 1901094-3 | - | 2168400-6 (QUANTITY 2) |
| | | | | | SMART APPLICATOR | 2161326-1 | - | 8-2266394-4 | - | - | |
| | | | | | MECHANICAL FEED | 2119949-1 | 1338685-1 | 5-18022-5 | 2119653-1 | - | - |
| | 2266394-5 | A | FINE CRIMP HEIGHT ADJUST | SERVO LATCH PLATE | SERVO LATCH PLATE | 2119951-1 | - | 8-2266394-5 | 1901094-3 | - | 2168400-6 (QUANTITY 2) |
| | | | | | SMART APPLICATOR | 2161326-1 | - | 8-2266394-4 | - | - | |
| | | | | | MECHANICAL FEED | 2119949-1 | 1338685-1 | 5-18022-5 | 2119653-1 | - | - |
| 2266394-6 | A | NON-CRIMP HEIGHT ADJUST | SERVO LATCH PLATE | - | - | - | - | - | - | - | |
| 2266394-7 | A | FINE CRIMP HEIGHT ADJUST | NONE | - | - | - | - | - | - | - | |
| 7-2266394-7 | A | CRIMP TOOLING KIT | - | - | - | - | - | - | - | - | |

| APPLICATOR DATA | | |
|--------------------------------------|----------------|------|
| CRIMP | SIZE | TYPE |
| WIRE | 1.78 mm [.070] | F |
| INSUL | 3.56 mm [.140] | O |
| APPLICATOR INSTRUCTIONS 408-10389 | | |

| TERMINAL DATA: HULANE TERMINAL | TE CRIMP SPECIFICATION |
|--|------------------------------------|
| TERMINAL NAME: TERMINAL | |
| WIRE STRIP LENGTH 4.60-5.40 mm [.181-.213 IN] | INSULATION DIAMETER RANGE Ø - - |
| TERMINAL APPLICATION SPECIFICATION NONE | |

| TERMINALS APPLIED | | | | |
|-------------------|-----------------|-----------|---------------|----------------|
| TE TERMINAL | HULANE TERMINAL | TE SEAL | FANGYUAN SEAL | CABLE DIAMETER |
| 2113510-1 | 891452PSG | 2113500-1 | 7165-33541A | 1.6-2.1mm |

| WIRE SIZE | CRIMP HEIGHT mm [INCH] | CRIMP HEIGHT REFERENCE SETTING |
|-----------|-----------------------------|--------------------------------|
| 1.00mm2 | 1.48+/-0.05 [1.058+/-0.002] | 7.5 |
| 0.50mm2 | 1.25+/-0.05 [1.049+/-0.002] | 10.2 |

- 1. RECOMMENDED SPARE PARTS
- 2. GREASE BEARING SURFACES LIGHTLY
- 3. LUBRICATE DAILY PER THE APPLICATOR INSTRUCTION SHEET SUPPLIED WITH THE APPLICATOR.
- 4. APPLICATOR SPECIFIC DATA TO BE ENTERED INTO BLANK MEMORY CHIP AT ASSEMBLY. SEE BELOW FOR PART NUMBER:
MECHANICAL FEED WITH "SMART APPLICATOR" CONVERSION: 8-2266394-4
PNEUMATIC FEED WITH "SMART APPLICATOR" CONVERSION: 8-2266394-4
SERVO FEED WITH "FINE CRIMP HEIGHT ADJUST": 8-2266394-5
SERVO FEED WITH "NON-CRIMP HEIGHT ADJUST": 8-2266394-6
- 5. ADJUSTMENT OF THE STRIPPER MAY BE REQUIRED WHEN MOVING THE APPLICATOR BETWEEN BENCH AND LEADMAKER APPLICATIONS.
- 6. APPLY PART NUMBER 1-23419-5 LOCTITE TO THREADS OF ITEM 62. APPLY PART NUMBER 2-23419-6 LOCTITE TO THREADS OF ITEM 242. FOR -6 ONLY APPLY PART NUMBER 1-23419-5 LOCTITE TO THREADS OF ITEM 37.
- 7. GREASE THREADS, GROOVE AND O-RING ON ITEMS 35 & 252.
- 8. MAGNET, ITEM 166 MUST BE ORIENTED CORRECTLY IN ORDER TO PROPERLY ACTUATE THE COUNTER.
- 9. CRIMP HEIGHT REFERENCE SETTING WAS THE SETTING USED WHEN THE APPLICATOR WAS QUALIFIED AT THE FACTORY. ADJUSTMENT MAY BE NECESSARY WHEN RUNNING APPLICATOR IN THE FIELD.
- 10. SPARE FEED CAM STORAGE LOCATION REFER TO INSTRUCTION SHEET FOR ADDITIONAL INFORMATION.
- 11. TO CONVERT THE APPLICATOR TO A NON-CARRIER CUTTING STYLE, REMOVE ITEM 13 AND ATTACH TO THE LOCATION ON THE BACK SIDE OF THE HOUSING. REFER TO INSTRUCTION SHEET FOR ADDITIONAL INFORMATION.
- 12. WHEN ASSEMBLING A NON CRIMP HEIGHT ADJUST APPLICATOR (-6) USE SHIMS FROM ITEM 260 TO ACHIEVE A NOMINAL SHIM HEIGHT OF 4.32.
- 13. THIS APPLICATOR APPLIES TERMINAL WITH A SEAL.
- 14. APPLY TORO-SEAL IN ALLEN SOCKET TO FILL HOLE AFTER FLAT HD HAS BEEN ADJUSTED TO CORRECT HEIGHT AT QUALIFICATION. APPLY #1-23419-5 LOC-TITE TO THREADS.

***WARNING**
ON INSTALLATION, SET WIRE DISC, ITEM 40 TO LARGEST WIRE SIZE SETTING. USE OF SETTINGS BELOW MINIMUM REQUIRED CRIMP HEIGHT SETTING WILL CAUSE DAMAGE TO CRIMP TOOLING.

| | | | | | | | | |
|-----|----|----|----|----|----|-----------|---------------------------------|---------|
| - | - | 1 | - | - | - | 2119957-2 | APPLICATOR SHIM PACK | 260 |
| - | 1 | - | 1 | 1 | 1 | 8-21084-0 | O-RING, .676 ID, .070 DIA. MAT. | 252 |
| - | - | - | - | 1 | - | 2119640-1 | PUSH ROD, AIR FEED | 250 |
| -77 | -7 | -6 | -5 | -2 | -1 | PART NO | DESCRIPTION | ITEM NO |

ATLANTIC VERSION
Shown on sheets 1 of 4 & 2 of 4
(Pacific version shown on sheets 3 of 4 & 4 of 4)

| SET UP GAUGE | LOC | DIST | REVISIONS | | | | | |
|--------------|-----|------|-----------|----------|-------------|-----------|-----|------|
| 2119599-1 | A | 66 | P | LTN | DESCRIPTION | DATE | OWN | APVD |
| | | | A | RELEASED | | 09SEP2014 | KH | UG |

| | | | | | | | | |
|-----|-----|-----|-----|-----|-----|-------------|-------------------------------------|---------|
| - | - | - | - | 1 | - | 2079988-1 | BUSHING, LCH5-12, MISUMI | 249 |
| - | - | - | - | 1 | - | 2119641-1 | FEED CAM, AIR FEED | 248 |
| - | 1 | - | 1 | 1 | 1 | 2119798-1 | DETENT PIN | 247 |
| - | 1 | - | 1 | 1 | 1 | 1-22279-3 | SPRING, COMPRESSION | 246 |
| - | - | 1 | - | - | - | 2119758-1 | RAM, AMP STYLE, SIDE FEED, NON-ADJ. | 245 |
| - | 1 | 1 | 1 | 1 | 1 | 2119082-2 | CAM, SNAIL, INSULATION ADJUSTMENT | 244 |
| - | 1 | 1 | 1 | 1 | 1 | 2079764-1 | WASHER, WAVE SPRING, CREST-TO-CREST | 243 |
| - | 1 | 1 | 1 | 1 | 1 | 2119083-1 | RETAINER, INSULATION DIAL | 242 |
| - | 1 | 1 | 1 | 1 | 1 | 7-18023-7 | SCR, SKT HD CAP M3 X 4.0 | 241 |
| - | - | 2 | 2 | - | - | 2168400-6 | SHCS, LOW HEAD, RoHS, M5 X 16 | 240 |
| - | - | - | - | - | 1 | 2119580-1 | MECHANICAL FEED ASSEMBLY | 239 |
| - | - | - | - | 1 | - | 2063440-1 | AIR FEED MODULE | 238 |
| - | - | 1 | 1 | - | - | 2119740-2 | TAG, IDENTIFICATION | 213 |
| - | - | 1 | 1 | - | - | 1901094-3 | SPACER, FEEDER | 198 |
| - | - | - | - | 2 | - | 21045-3 | RING, RETAIN, EXTERN, 3/16 CRESCENT | 172 |
| - | 1 | 1 | 1 | 1 | 1 | 994969-1 | MAGNET, RARE EARTH HIGH ENERGY | 166 |
| - | REF | REF | REF | REF | REF | 994970-2 | COUNTER, MAGNETIC | 164 |
| - | - | - | - | 1 | - | 240638-1 | SPRING, FEED FINGER | 163 |
| - | - | - | - | 1 | - | 3-23627-7 | PIN, RETAIN, GRVD, 3/16 X .854 | 137 |
| - | - | - | - | 1 | - | 2119799-1 | HOLDER, FEED FINGER, AF | 136 |
| - | - | REF | REF | - | - | SEE NOTE 4 | MEMORY CHIP, PROGRAMMED | 135 |
| - | - | 1 | 1 | - | - | 1633743-1 | SERVO FEED LATCH ASM | 133 |
| - | - | REF | REF | - | - | 2119944-1 | FEED FINGER ASSEMBLY, SF | 117 |
| - | 1 | 1 | 1 | 1 | 1 | 455888-6 | SPACER, CRIMPER | 82 |
| - | 1 | 1 | 1 | 1 | 1 | 2119956-1 | DOCUMENTATION PACKAGE | 71 |
| - | 1 | 1 | 1 | 1 | 1 | 2119791-9 | DEPRESSOR, WIRE | 70 |
| - | 1 | - | - | 1 | 1 | 2119740-1 | TAG, IDENTIFICATION | 67 |
| - | 2 | 2 | 2 | 2 | 2 | 2168078-1 | SCREW, DRIVE, RH, RoHS, 2 x .188 | 66 |
| - | 1 | - | 1 | 1 | 1 | 2119793-1 | LIMITER, ADJUSTMENT BOLT | 63 |
| - | 3 | - | 3 | 3 | 3 | 992763-5 | SCR, SET, SOC, CONE POINT, M3 x 4.0 | 62 |
| - | 1 | 1 | 1 | 1 | 1 | 2079383-4 | SCR, BHSC, RoHS (M4 X 8) | 60 |
| - | - | - | - | 1 | 1 | 5-18022-5 | SCR, HEX HD CAP, M4 X 6.0 | 59 |
| - | 1 | 1 | 1 | 1 | 1 | 985575-3 | SCR, FLT SKT HD CAP M3 X 10.0 | 57 |
| - | - | - | - | 1 | 1 | 1338685-1 | PAWL, FEED | 56 |
| - | 4 | 4 | 4 | 4 | 4 | 2168400-1 | SHCS, LOW HEAD, RoHS, M4 X 12 | 54 |
| - | 2 | 2 | 2 | 2 | 2 | 1-2168083-0 | SCR, SKT HD CAP, RoHS, M4 X 10 | 53 |
| - | 1 | 1 | 1 | 1 | 1 | 5018030-1 | NUT, HEX, REG, RoHS, M3 | 52 |
| - | 1 | 1 | 1 | 1 | 1 | 811242-5 | BUMPER, HOLD DOWN | 51 |
| - | 1 | 1 | 1 | 1 | 1 | 690753-2 | SPACER, TONKER | 50 |
| - | - | - | - | 1 | 2 | 18023-9 | SCR, SKT HD CAP M4 X 6.0 | 49 |
| - | - | - | - | - | 1 | 2119652-1 | FEED CAM, PRE FEED | 48 |
| - | - | - | - | - | 1 | 2119653-1 | FEED CAM, POST FEED | 47 |
| - | 1 | 1 | 1 | 1 | 1 | 2119656-9 | APPLICATOR BASIC ASSEMBLY, SF | 46 |
| - | 1 | - | 1 | 1 | 1 | 2119370-1 | RAM, AMP STYLE, SIDE FEED | 44 |
| - | 1 | 1 | 1 | 1 | 1 | 2079383-7 | SCR, BHSC, RoHS (M8 X 25) | 41 |
| - | 1 | - | 1 | 1 | 1 | 2119645-1 | DISC, NUMBERED FA WIRE ADJUSTMENT | 40 |
| - | 1 | - | 1 | 1 | 1 | 2119957-1 | APPLICATOR SHIM PACK | 39 |
| - | 1 | 1 | 1 | 1 | 1 | 1-2119644-2 | RAM WASHER, PRECISION | 38 |
| - | 1 | 1 | 1 | 1 | 1 | 2119085-1 | FA HEAD, ATLANTIC STYLE | 37 |
| - | 1 | - | 1 | 1 | 1 | 2119092-1 | BOLT, ADJUSTMENT | 35 |
| - | 1 | 1 | 1 | 1 | 1 | 1-1752356-8 | SUPPORT, TERMINAL | 34 |
| - | 2 | 2 | 2 | 2 | 2 | 2079383-5 | SCR, BHSC, RoHS (M4 X 20) | 33 |
| - | 1 | 1 | 1 | 1 | 1 | 2161328-1 | HEX HEAD, FLANGED, M5 x 8mm LONG | 32 |
| - | 1 | 1 | 1 | 1 | 1 | 1-1320908-0 | SPACER, STRIP GUIDE | 30 |
| - | 1 | 1 | 1 | 1 | 1 | 2119959-1 | ASSEMBLY, STRIP GUIDE | 29 |
| - | 1 | 1 | 1 | 1 | 1 | 455888-3 | SPACER, CRIMPER | 28 |
| - | 1 | 1 | 1 | 1 | 1 | 1320928-2 | STRIP GUIDE | 24 |
| - | 1 | 1 | 1 | 1 | 1 | 2168083-2 | SCR, SKT HD CAP, RoHS, M4 X 8.0 | 21 |
| - | 2 | 2 | 2 | 2 | 2 | 1-18028-2 | WASHER, FLAT, REG M4 | 20 |
| - | 1 | 1 | 1 | 1 | 1 | 2119533-1 | STRIPPER, SIDE FEED | 19 |
| - | 1 | 1 | 1 | 1 | 1 | 2119806-1 | INSERT, SHEAR | 13 |
| - | 1 | 1 | 1 | 1 | 1 | 3-22280-3 | SPRING, COMPRESSION | 12 |
| - | 1 | 1 | 1 | 1 | 1 | 1-356885-4 | STOP, SHEAR | 11 |
| - | 1 | 1 | 1 | 1 | 1 | 2119805-1 | SHEAR HOLDER, FRONT | 10 |
| - | 1 | 1 | 1 | 1 | 1 | 318707-1 | FLOATING SHEAR, FRONT | 9 |
| - | 1 | 1 | 1 | 1 | 1 | 1-1803056-5 | ANVIL, COMBINATION | 8 |
| - | - | - | - | - | - | - | - | 7 |
| - | - | - | - | - | - | - | - | 6 |
| - | 1 | 1 | 1 | 1 | 1 | 2119781-6 | DEPRESSOR, SHEAR | 5 |
| - | 1 | 1 | 1 | 1 | 1 | 238011-4 | BLOCK, CRIMPER SPACER | 4 |
| - | 1 | 1 | 1 | 1 | 1 | 1803018-8 | CRIMPER, INSULATION O | 3 |
| - | 1 | 1 | 1 | 1 | 1 | 455888-6 | SPACER, CRIMPER | 2 |
| - | 1 | 1 | 1 | 1 | 1 | 5-456404-3 | CRIMPER, WIRE PREMIUM | 1 |
| -77 | -7 | -6 | -5 | -2 | -1 | PART NO | DESCRIPTION | ITEM NO |

| DIMENSIONS: | | TOLERANCES UNLESS OTHERWISE SPECIFIED: | | DATE | |
|-------------|---------------|--|-----------|-----------|-----------|
| mm | 0 PLC ±.5 | 1 PLC ±.5 | 2 PLC ±.5 | 3 PLC ±.5 | 4 PLC ±.5 |
| | ANGLES ±.0001 | | | | |
| MATERIAL: | FINISH: | WEIGHT: | SCALE: | SHEET: | REV: |
| | | | 1:2 | 1 OF 4 | A |

SHEETS 3 & 4 ARE NOT REQUIRED FOR ATLANTIC VERSION

| REVISONS | | DATE | DWN | APVD |
|----------|------|-------------|-----|------|
| LOC | DIST | | | |
| A | 66 | | | |
| P | LTM | DESCRIPTION | | |
| | | SEE SHEET 1 | | |

FEED TYPE MECHANICAL



PNEUMATIC

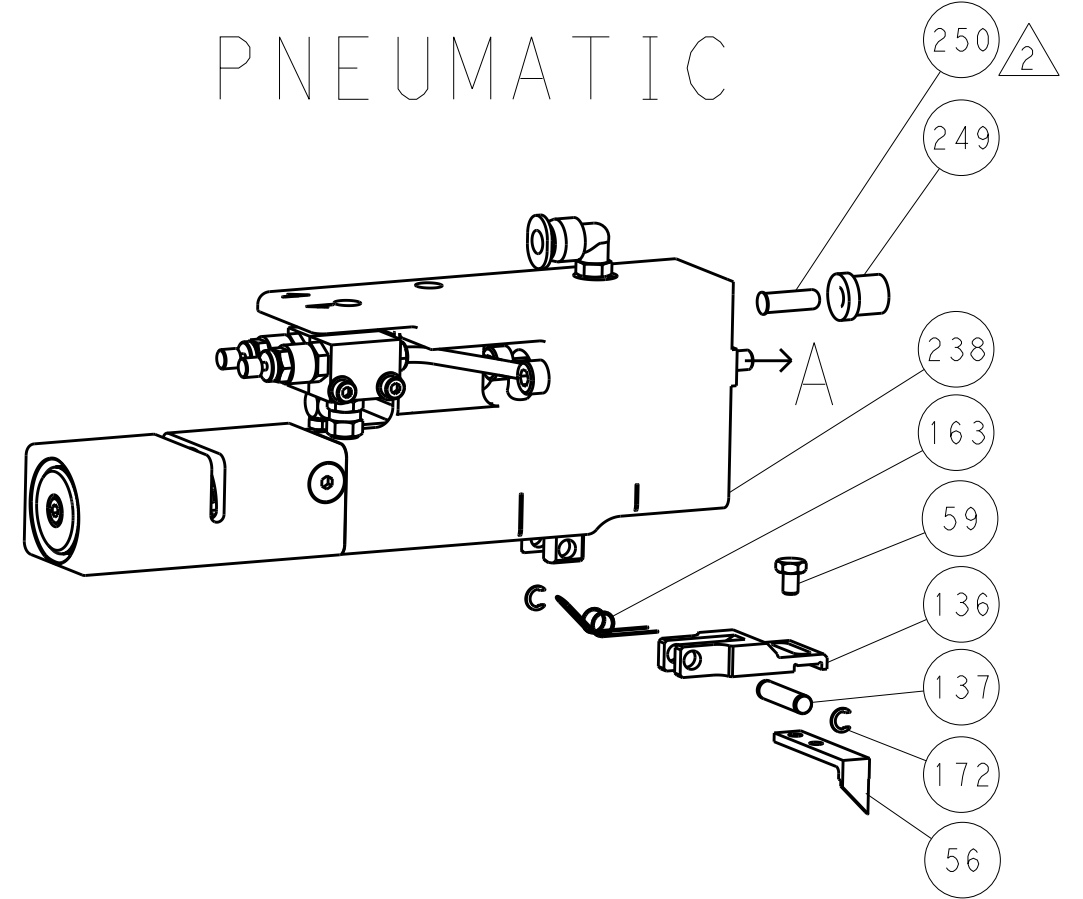

SERVO LATCH PLATE



CAM POSITIONS

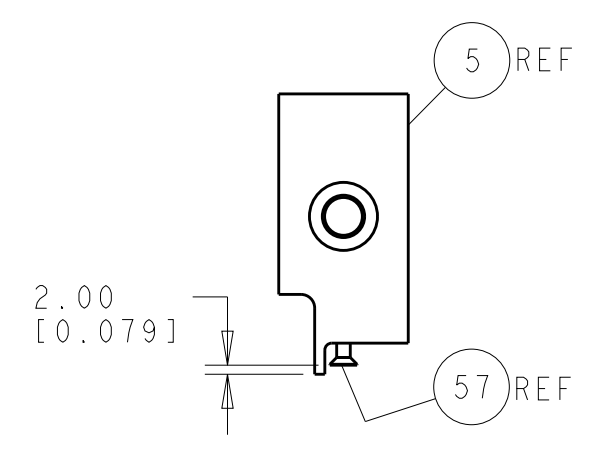
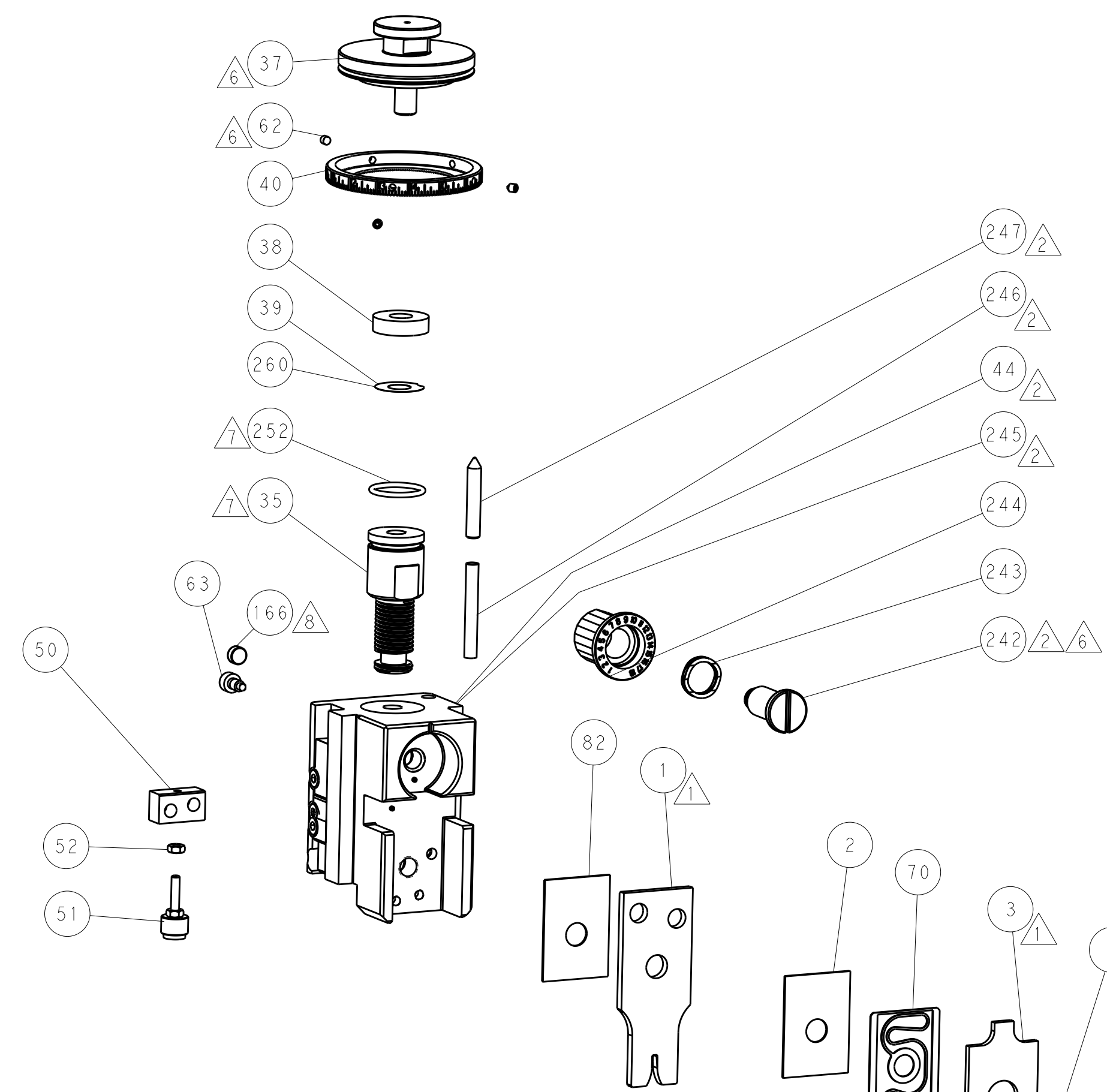

SHEAR DEPRESSOR DETAIL

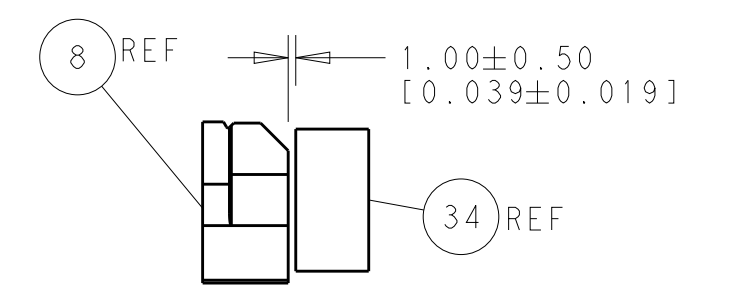

TERMINAL SUPPORT LOCATION

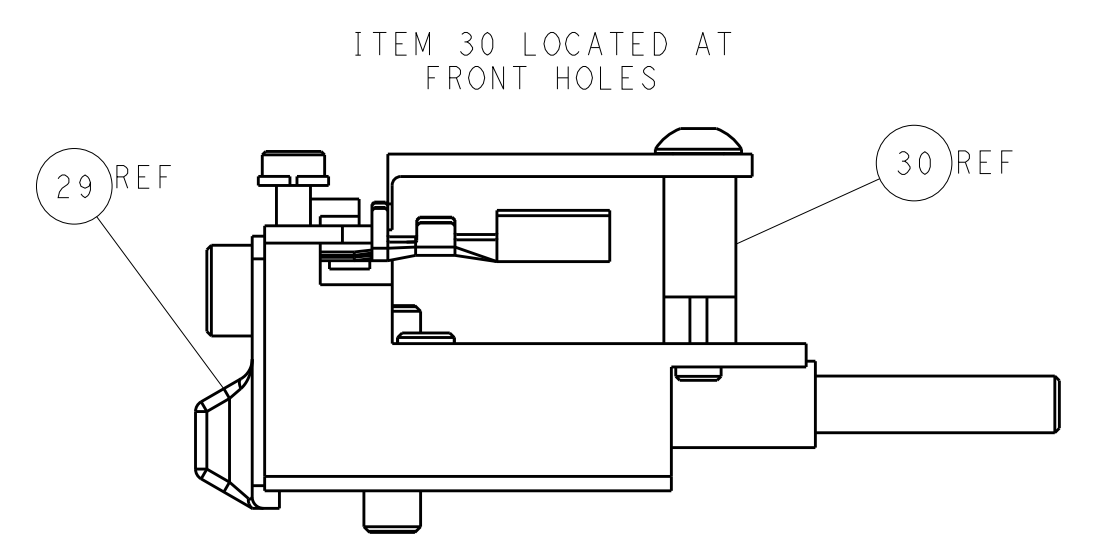
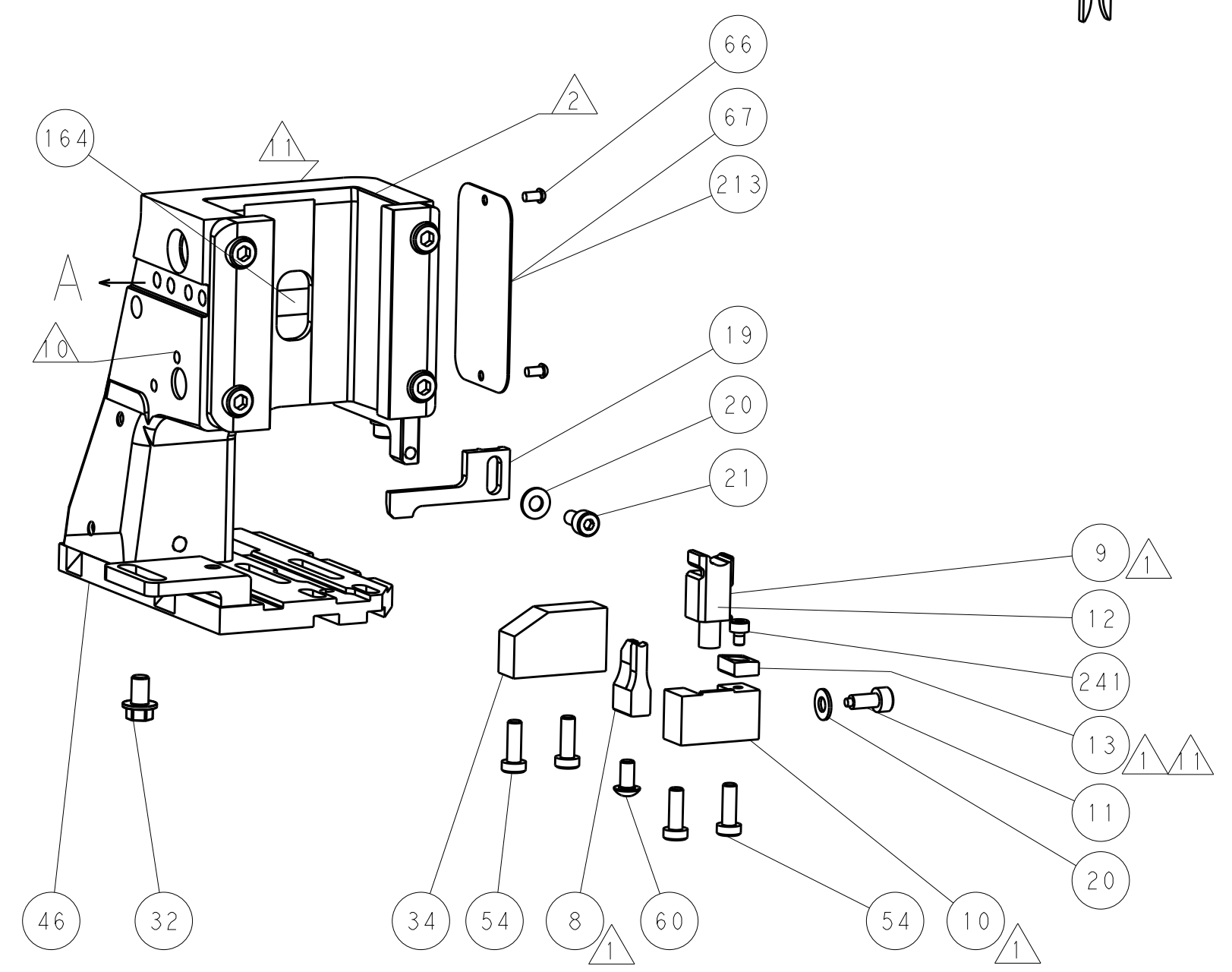
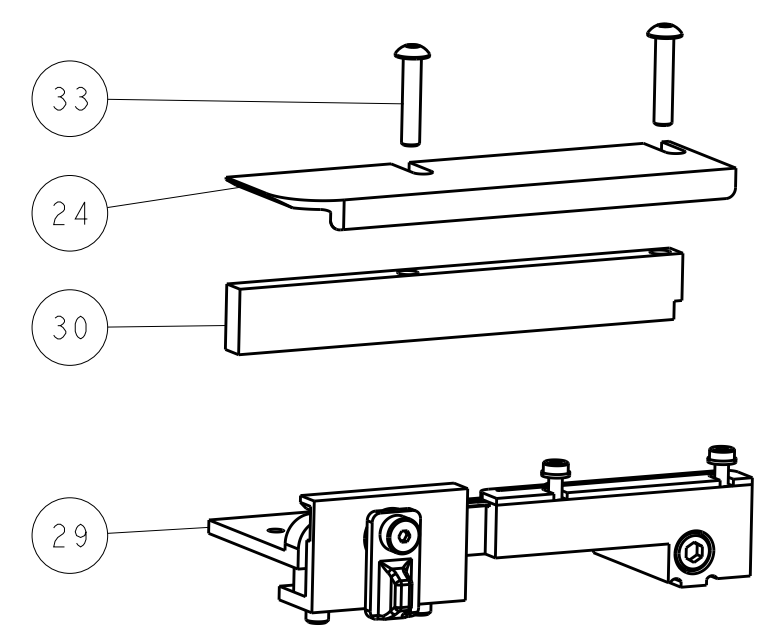

FEED TRACK POSITION GUIDE BY INSULATION BARREL

ATLANTIC VERSION
 Shown on sheets 1 of 4 & 2 of 4
 (Pacific version shown on sheets 3 of 4 & 4 of 4)

| | | | | | | | |
|-------------|------------|--|-------------|--|--------------|--|---------------------------|
| DIMENSIONS: | | TOLERANCES UNLESS OTHERWISE SPECIFIED: | | DWN 04JUL2014 | | TE Connectivity | |
| mm | 0 PLC ±0.5 | 1 PLC ±0.5 | 2 PLC ±0.13 | 3 PLC ±0.013 | 4 PLC ±0.001 | APVD 04JUL2014 | Harrisburg, PA 17105-3608 |
| MATERIAL: | | FINISH: | | NAME | | Ocean Side Feed Applicator | |
| | | | | SIZE | | RESTRICTED TO | |
| | | | | A1 00779 | | C=2266394 | |
| | | | | WEIGHT | | SCALE 1:2 SHEET 2 OF 4 REV A | |
| | | | | Customer Accessible Production Drawing | | SHEETS 3 & 4 ARE NOT REQUIRED FOR ATLANTIC VERSION | |

| PACIFIC VERSION TERMINATOR INTERFACE ADAPTER | PART NUMBER | REVISION | DESCRIPTION | FEED TYPE | APPLICATOR STYLE CONVERSION CHART | | | | | | |
|--|-------------|----------|--------------------------|-------------------|-----------------------------------|-----------------------|-----------|-------------|-----------|-----------|------------------------|
| | | | | | CONVERT TO | PART NUMBERS REQUIRED | | | | | |
| | 2-2266394-1 | A | FINE CRIMP HEIGHT ADJUST | MECHANICAL | PNEUMATIC FEED | 2119950-1 | 1338685-1 | 5-18022-5 | 2119641-2 | 2119799-1 | 2063440-1 |
| | | | | | SERVO LATCH PLATE | 2119951-1 | - | 8-2266394-5 | 1901094-3 | - | 2168400-6 (QUANTITY 2) |
| | | | | | SMART APPLICATOR | 2161326-1 | - | 8-2266394-4 | - | - | - |
| | 2-2266394-2 | A | FINE CRIMP HEIGHT ADJUST | PNEUMATIC | MECHANICAL FEED | 2119949-1 | 1338685-1 | 5-18022-5 | 2119653-2 | - | - |
| | | | | | SERVO LATCH PLATE | 2119951-1 | - | 8-2266394-5 | 1901094-3 | - | 2168400-6 (QUANTITY 2) |
| | | | | | SMART APPLICATOR | 2161326-1 | - | 8-2266394-4 | - | - | - |
| | 2-2266394-5 | A | FINE CRIMP HEIGHT ADJUST | SERVO LATCH PLATE | MECHANICAL FEED | 2119949-1 | 1338685-1 | 5-18022-5 | 2119653-2 | - | - |
| | | | | | PNEUMATIC FEED | 2119950-1 | 1338685-1 | 5-18022-5 | 2119641-2 | 2119799-1 | 2063440-1 |
| | 2-2266394-7 | A | FINE CRIMP HEIGHT ADJUST | NONE | - | - | - | - | - | - | - |
| | 7-2266394-7 | A | CRIMP TOOLING KIT | - | - | - | - | - | - | - | - |

| APPLICATOR DATA | | |
|--------------------------------------|----------------|------|
| CRIMP | SIZE | TYPE |
| WIRE | 1.78 mm [.070] | F |
| INSUL | 3.56 mm [1.40] | O |
| APPLICATOR INSTRUCTIONS 408-10389 | | |

| TERMINAL DATA: HULANE TERMINAL | | TE CRIMP SPECIFICATION | |
|------------------------------------|-----------------|---------------------------|----------------|
| TERMINAL NAME: TERMINAL | | | |
| WIRE STRIP LENGTH | | INSULATION DIAMETER RANGE | |
| 4.60-5.40 mm [1.81-.213 IN] | | ∅ | △ |
| TERMINAL APPLICATION SPECIFICATION | NONE | - | - |
| TERMINALS APPLIED | | | |
| TE TERMINAL | HULANE TERMINAL | TE SEAL | FANGYUAN SEAL |
| 2113510-1 | 891452PSG | 2113500-1 | 7165-33541A |
| | | | CABLE DIAMETER |
| | | | 1.6-2.1mm |

| WIRE SIZE | CRIMP HEIGHT mm [INCH] | CRIMP HEIGHT REFERENCE SETTING |
|-----------|-----------------------------|--------------------------------|
| 1.00mm2 | 1.48+/-0.05 [1.058+/-0.002] | 7.5 |
| 0.50mm2 | 1.25+/-0.05 [1.049+/-0.002] | 10.2 |

- △ RECOMMENDED SPARE PARTS
- △ GREASE BEARING SURFACES LIGHTLY
- 3. LUBRICATE DAILY PER THE APPLICATOR INSTRUCTION SHEET SUPPLIED WITH THE APPLICATOR.
- △ APPLICATOR SPECIFIC DATA TO BE ENTERED INTO BLANK MEMORY CHIP AT ASSEMBLY. SEE BELOW FOR PART NUMBER:
 MECHANICAL FEED WITH "SMART APPLICATOR" CONVERSION: 8-2266394-4
 PNEUMATIC FEED WITH "SMART APPLICATOR" CONVERSION: 8-2266394-4
 SERVO FEED WITH "FINE CRIMP HEIGHT ADJUST": 8-2266394-5
- 5. ADJUSTMENT OF THE STRIPPER MAY BE REQUIRED WHEN MOVING THE APPLICATOR BETWEEN BENCH AND LEADMAKER APPLICATIONS.
- △ APPLY PART NUMBER 1-23419-5 LOCTITE TO THREADS OF ITEM 62.
 APPLY PART NUMBER 2-23419-6 LOCTITE TO THREADS OF ITEM 242.
- △ GREASE THREADS, GROOVE AND O-RING ON ITEMS 139 & 152.
- △ MAGNET MUST BE ORIENTED CORRECTLY IN ORDER TO PROPERLY ACTUATE THE COUNTER.
- △ CRIMP HEIGHT REFERENCE SETTING WAS THE SETTING USED WHEN THE APPLICATOR WAS QUALIFIED AT THE FACTORY. ADJUSTMENT MAY BE NECESSARY WHEN RUNNING APPLICATOR IN THE FIELD.
- △ SPARE FEED CAM STORAGE LOCATION REFER TO INSTRUCTION SHEET FOR ADDITIONAL INFORMATION.
- △ TO CONVERT THE APPLICATOR TO A NON-CARRIER CUTTING STYLE, REMOVE ITEM 13 AND ATTACH TO THE LOCATION ON BACK SIDE OF THE HOUSING. REFER TO INSTRUCTION SHEET FOR ADDITIONAL INFORMATION.
- △ THIS APPLICATOR APPLIES TERMINAL WITH A SEAL.
- △ APPLY TORQ-SEAL IN ALLEN SOCKET TO FILL HOLE AFTER FLAT HD HAS BEEN ADJUSTED TO CORRECT HEIGHT AT QUALIFICATION.
 APPLY #1-23419-5 LOC-TITE TO THREADS.

*WARNING
 ON INSTALLATION, SET WIRE DISC, ITEM 40 TO LARGEST WIRE SIZE SETTING. USE OF SETTINGS BELOW MINIMUM REQUIRED CRIMP HEIGHT SETTING WILL CAUSE DAMAGE TO CRIMP TOOLING.

| | | | | | | | |
|-----|-----|-----|-----|-----|-----------|-------------------------------------|---------|
| - | 1 | 1 | 1 | 1 | 2119782-1 | FINE ADJUST HEAD ASM, PACIFIC STYLE | 251 |
| -77 | -27 | -25 | -22 | -21 | PART NO | DESCRIPTION | ITEM NO |

PACIFIC VERSION
 Shown on sheets 3 of 4 & 4 of 4
 (Atlantic version shown on sheets 1 of 4 & 2 of 4)

| SET UP GAUGE | LOC | DIST | REVISIONS | | | |
|--------------|-----|------|-----------|-------------|----|------|
| 2119599-1 | A | 66 | REV | DATE | BY | APPD |
| | | | - | SEE SHEET 1 | - | - |

| | | | | | | | | |
|---|-----|-----|-----|-----|-------------|-------------------------------------|-------------------------|-----|
| - | - | - | 1 | - | 2119640-1 | PUSH ROD, AIR FEED | 250 | |
| - | - | - | 1 | - | 2079988-1 | BUSHING, LCH5-12, MISUMI | 249 | |
| - | 1 | 1 | 1 | 1 | 1-22279-3 | SPRING, COMPRESSION | 246 | |
| - | 1 | 1 | 1 | 1 | 2119082-2 | CAM, SNAIL, INSULATION ADJUSTMENT | 244 | |
| - | 1 | 1 | 1 | 1 | 2079764-1 | WASHER, WAVE SPRING, CREST-TO-CREST | 243 | |
| - | 1 | 1 | 1 | 1 | 2119083-1 | RETAINER, INSULATION DIAL | 242 | |
| - | 1 | 1 | 1 | 1 | 7-18023-7 | SCR, SKT HD CAP M3 X 4.0 | 241 | |
| - | - | 2 | - | - | 2168400-6 | SHCS, LOW HEAD, RoHS, M5 X 16 | 240 | |
| - | - | - | - | 1 | 2119580-1 | MECHANICAL FEED ASSEMBLY | 239 | |
| - | - | - | - | 1 | 2063440-1 | AIR FEED MODULE | 238 | |
| - | - | 1 | - | - | 2119740-2 | TAG, IDENTIFICATION | 213 | |
| - | - | 1 | - | - | 1901094-3 | SPACER, FEEDER | 198 | |
| - | - | - | 2 | - | 21045-3 | RING, RETAIN, EXTERN, 3/16 CRESCENT | 172 | |
| - | 1 | 1 | 1 | 1 | 994969-1 | MAGNET, RARE EARTH HIGH ENERGY | 166 | |
| - | REF | REF | REF | REF | 994970-2 | COUNTER, MAGNETIC | 164 | |
| - | - | - | 1 | - | 240638-1 | SPRING, FEED FINGER | 163 | |
| - | 1 | 1 | 1 | 1 | 8-21084-1 | O-RING, .801 ID, .070 DIA. MAT. | 152 | |
| - | - | - | 1 | - | 2119641-2 | FEED CAM, AIR FEED | 151 | |
| - | 1 | 1 | 1 | 1 | 2119798-2 | DETENT PIN | 145 | |
| - | 1 | 1 | 1 | 1 | 2079383-8 | SCR, BHSC, RoHS (M4 X 16) | 144 | |
| - | 4 | 4 | 4 | 4 | 2168400-5 | SHCS, LOW HEAD, RoHS, M4 X 20 | 143 | |
| - | - | - | - | 1 | 2119653-2 | FEED CAM, POST FEED | 142 | |
| - | 1 | 1 | 1 | 1 | 1-2119656-0 | APPLICATOR BASIC ASSEMBLY, SF | 141 | |
| - | 1 | 1 | 1 | 1 | 2119650-1 | RAM, ASIAN STYLE, SIDE FEED | 140 | |
| - | 1 | 1 | 1 | 1 | 2119092-2 | BOLT, ADJUSTMENT | 139 | |
| - | - | - | 1 | - | 3-23627-7 | PIN, RETAIN, GRVD, 3/16 X .854 | 137 | |
| - | - | - | 1 | - | 2119799-1 | HOLDER, FEED FINGER, AF | 136 | |
| - | - | REF | - | - | - | SEE NOTE 4 | MEMORY CHIP, PROGRAMMED | 135 |
| - | - | 1 | - | - | 1633743-1 | SERVO FEED LATCH ASM | 133 | |
| - | - | REF | - | - | 2119944-1 | FEED FINGER ASSEMBLY, SF | 117 | |
| - | 1 | 1 | 1 | 1 | 455888-6 | SPACER, CRIMPER | 82 | |
| - | 1 | 1 | 1 | 1 | 2119956-1 | DOCUMENTATION PACKAGE | 71 | |
| - | 1 | 1 | 1 | 1 | 2119791-9 | DEPRESSOR, WIRE | 70 | |
| - | 1 | - | 1 | 1 | 2119740-1 | TAG, IDENTIFICATION | 67 | |
| - | 2 | 2 | 2 | 2 | 2168078-1 | SCREW, DRIVE, RH, RoHS, 2 x .188 | 66 | |
| - | 1 | 1 | 1 | 1 | 2119793-1 | LIMITER, ADJUSTMENT BOLT | 63 | |
| - | 3 | 3 | 3 | 3 | 992763-5 | SCR, SET, SOC, CONE POINT, M3 x 4.0 | 62 | |
| - | - | - | 1 | 1 | 5-18022-5 | SCR, HEX HD CAP, M4 X 6.0 | 59 | |
| - | 1 | 1 | 1 | 1 | 985575-3 | SCR, FLT SKT HD CAP M3 X 10.0 | 57 | |
| - | - | - | 1 | 1 | 1338685-1 | PAWL, FEED | 56 | |
| - | 2 | 2 | 2 | 2 | 1-2168083-0 | SCR, SKT HD CAP, RoHS, M4 X 10 | 53 | |
| - | 1 | 1 | 1 | 1 | 5018030-1 | NUT, HEX, REG, RoHS, M3 | 52 | |
| - | 1 | 1 | 1 | 1 | 811242-5 | BUMPER, HOLD DOWN | 51 | |
| - | 1 | 1 | 1 | 1 | 690753-2 | SPACER, TONKER | 50 | |
| - | - | - | 1 | 2 | 18023-9 | SCR, SKT HD CAP M4 X 6.0 | 49 | |
| - | - | - | - | 1 | 2119652-1 | FEED CAM, PRE FEED | 48 | |
| - | 1 | 1 | 1 | 1 | 2079383-7 | SCR, BHSC, RoHS (M8 X 25) | 41 | |
| - | 1 | 1 | 1 | 1 | 2119645-1 | DISC, NUMBERED FA WIRE ADJUSTMENT | 40 | |
| - | 1 | 1 | 1 | 1 | 2119957-1 | APPLICATOR SHIM PACK | 39 | |
| - | 1 | 1 | 1 | 1 | 1-2119644-2 | RAM WASHER, PRECISION | 38 | |
| - | 1 | 1 | 1 | 1 | 1-1752356-8 | SUPPORT, TERMINAL | 34 | |
| - | 2 | 2 | 2 | 2 | 2079383-5 | SCR, BHSC, RoHS (M4 X 20) | 33 | |
| - | 1 | 1 | 1 | 1 | 2161328-1 | HEX HEAD, FLANGED, M5 x 8mm LONG | 32 | |
| - | 1 | 1 | 1 | 1 | 1-1320908-0 | SPACER, STRIP GUIDE | 30 | |
| - | 1 | 1 | 1 | 1 | 2119959-1 | ASSEMBLY, STRIP GUIDE | 29 | |
| - | 1 | 1 | 1 | 1 | 455888-3 | SPACER, CRIMPER | 28 | |
| - | 1 | 1 | 1 | 1 | 1320928-2 | STRIP GUIDE | 24 | |
| - | 1 | 1 | 1 | 1 | 2168083-2 | SCR, SKT HD CAP, RoHS, M4 X 8.0 | 21 | |
| - | 2 | 2 | 2 | 2 | 1-18028-2 | WASHER, FLAT, REG M4 | 20 | |
| - | 1 | 1 | 1 | 1 | 2119533-1 | STRIPPER, SIDE FEED | 19 | |
| - | 1 | 1 | 1 | 1 | 2119806-1 | INSERT, SHEAR | 13 | |
| - | 1 | 1 | 1 | 1 | 3-22280-3 | SPRING, COMPRESSION | 12 | |
| - | 1 | 1 | 1 | 1 | 1-356885-4 | STOP, SHEAR | 11 | |
| - | 1 | 1 | 1 | 1 | 2119805-1 | SHEAR HOLDER, FRONT | 10 | |
| - | 1 | 1 | 1 | 1 | 318707-1 | FLOATING SHEAR, FRONT | 9 | |
| △ | 1 | 1 | 1 | 1 | 1-1803056-5 | ANVIL, COMBINATION | 8 | |
| - | - | - | - | - | - | - | 7 | |
| - | - | - | - | - | - | - | 6 | |
| - | 1 | 1 | 1 | 1 | 2119781-6 | DEPRESSOR, SHEAR | 5 | |
| - | 1 | 1 | 1 | 1 | 238011-4 | BLOCK, CRIMPER SPACER | 4 | |
| △ | 1 | 1 | 1 | 1 | 1803018-8 | CRIMPER, INSULATION O | 3 | |
| △ | 1 | 1 | 1 | 1 | 455888-6 | SPACER, CRIMPER | 2 | |
| △ | 1 | 1 | 1 | 1 | 5-456404-3 | CRIMPER, WIRE PREMIUM | 1 | |

| DIMENSIONS: | | TOLERANCES UNLESS OTHERWISE SPECIFIED: | | DATE | | NAME | |
|-------------|-----------|--|-------------|--|---------------|---------------|--------|
| mm | 0 PLC ±.5 | 1 PLC ±0.5 | 2 PLC ±0.13 | 3 PLC ±0.013 | 4 PLC ±0.0013 | ANGLES ±.1 | FINISH |
| MATERIAL | | | | APVD | | RESTRICTED TO | |
| - | | | | H. GUO 04JUL2014 | | - | |
| - | | | | L. ZHANG 04JUL2014 | | - | |
| - | | | | APVD | | - | |
| - | | | | PRODUCT SPEC | | - | |
| - | | | | APPLICATION SPEC | | - | |
| - | | | | WEIGHT | | - | |
| - | | | | SCALE | | - | |
| - | | | | SHEET | | - | |
| - | | | | REV | | - | |
| - | | | | Customer Accessible Production Drawing | | - | |

| LOC | | DIST | | REVISIONS | | | |
|-----|----|------|-----|-------------|------|-----|------|
| A | 66 | P | LTM | DESCRIPTION | DATE | OWN | APVD |
| | | - | | SEE SHEET 1 | | | |

FEED TYPE MECHANICAL



PNEUMATIC

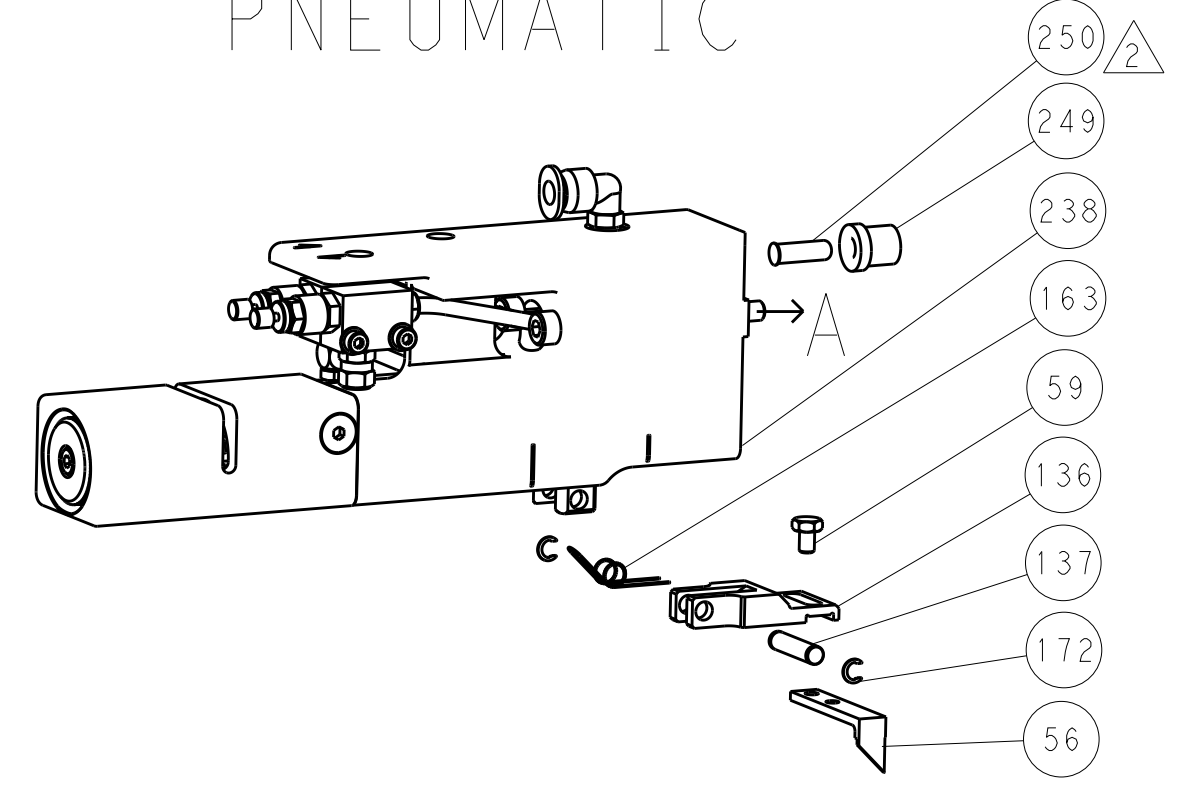

SERVO LATCH PLATE



CAM POSITIONS

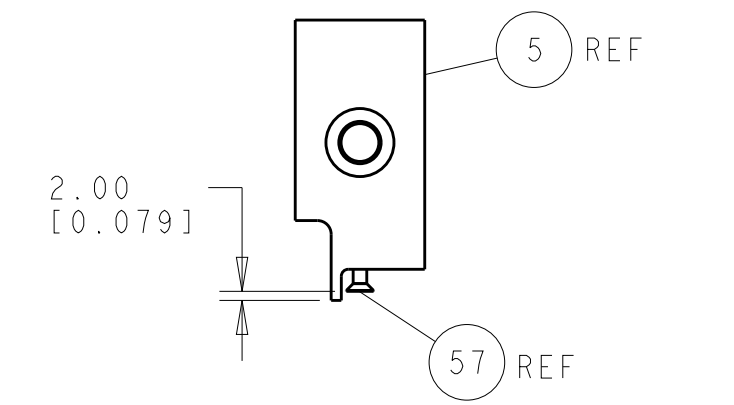
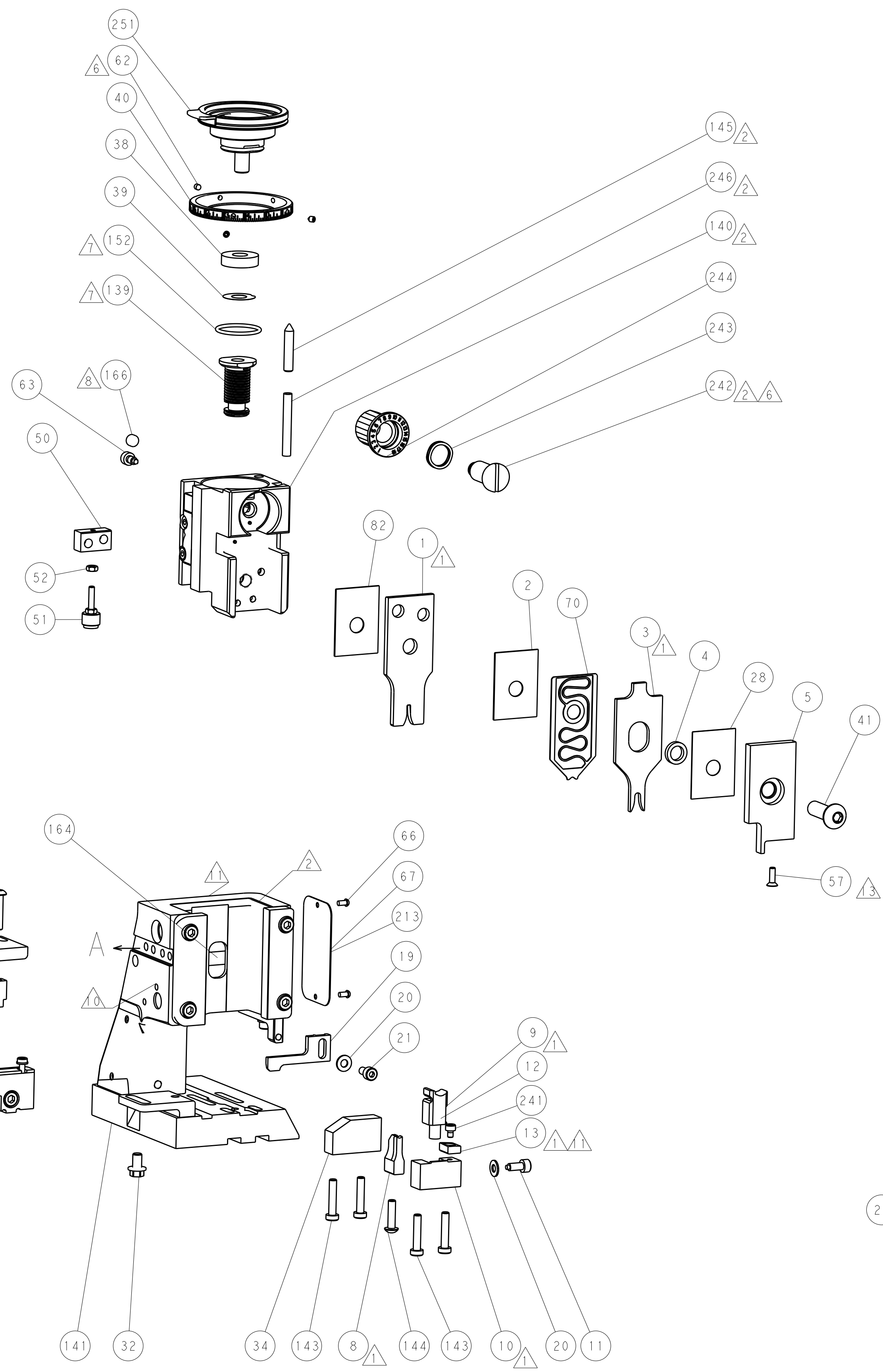
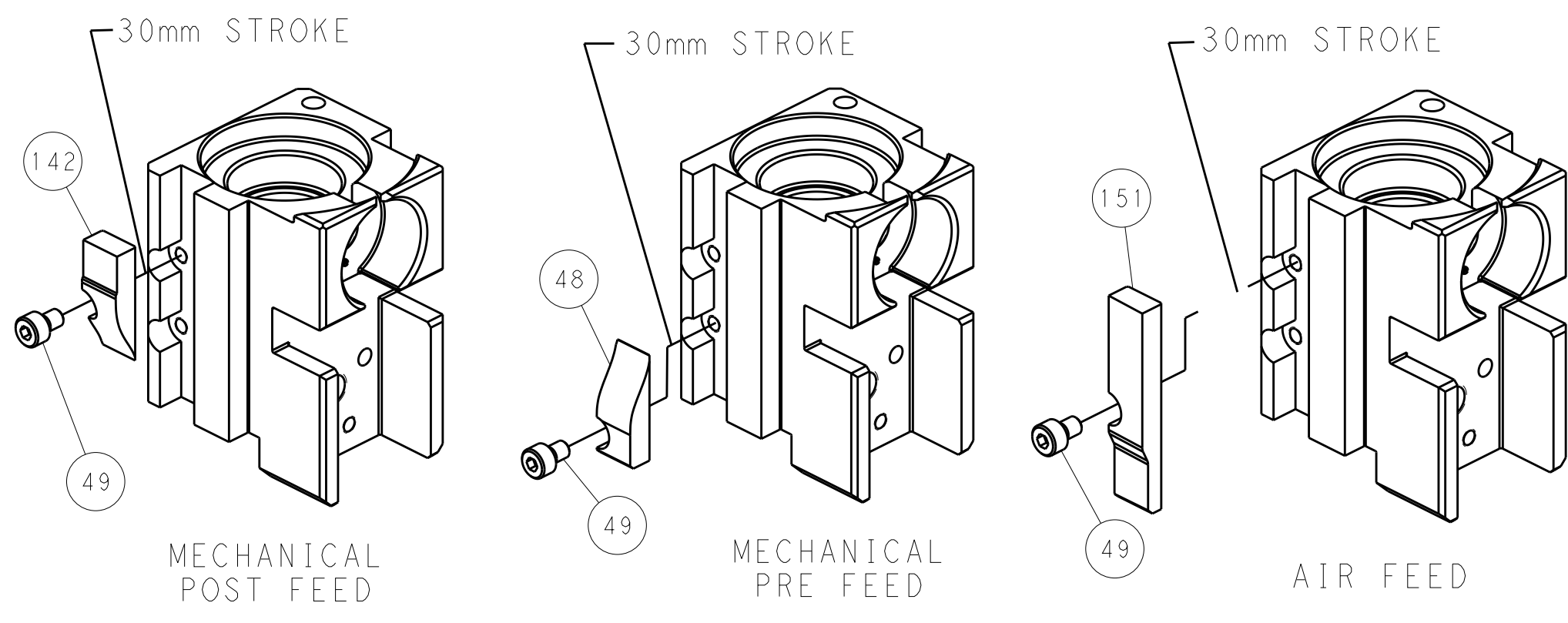

SHEAR DEPRESSOR DETAIL

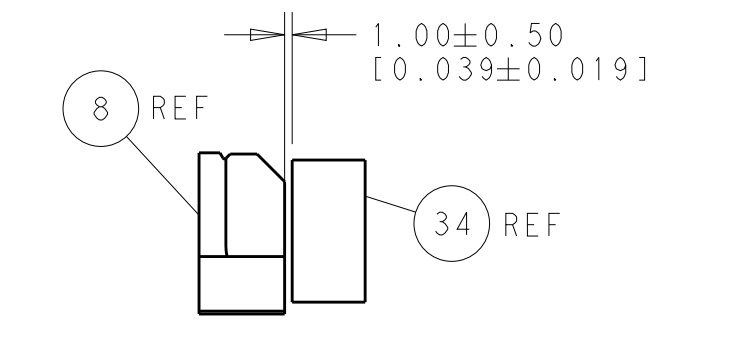

TERMINAL SUPPORT LOCATION

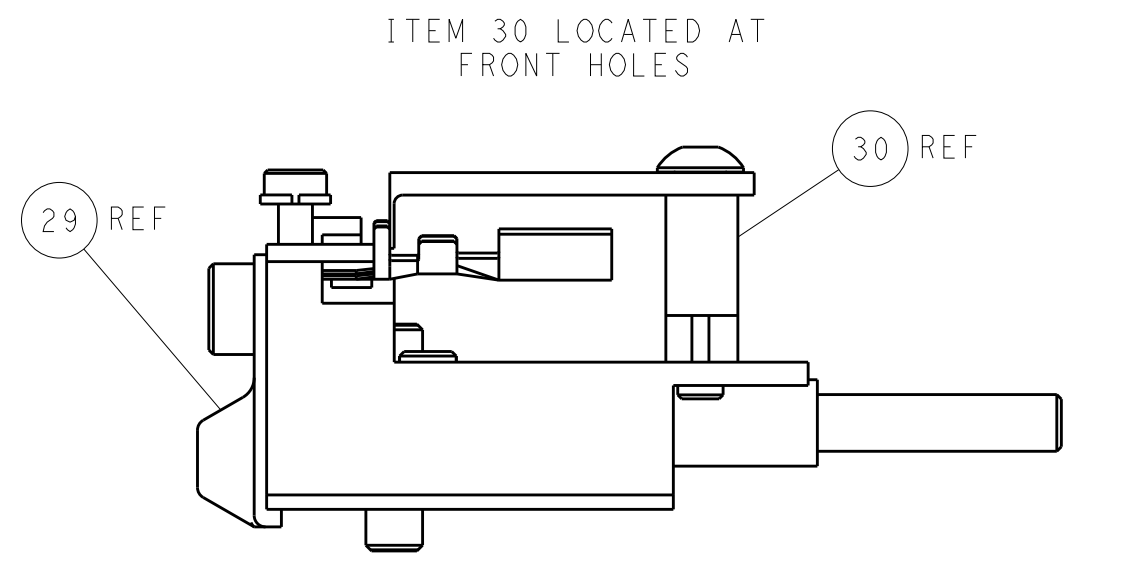

FEED TRACK POSITION GUIDE BY INSULATION BARREL

PACIFIC VERSION
 Shown on sheets 3 of 4 & 4 of 4
 (Atlantic version shown on sheets 1 of 4 & 2 of 4)

| | | | | | | | |
|--|------------|--|-------------|----------------------------------|--------------|--------------------------|---------------------------|
| DIMENSIONS: | | TOLERANCES UNLESS OTHERWISE SPECIFIED: | | DWN: H. HUANG 04JUL2014 | | STE Connectivity | |
| mm | 0 PLC ±0.5 | 1 PLC ±0.5 | 2 PLC ±0.13 | 3 PLC ±0.013 | 4 PLC ±0.001 | APVD: L. ZHANG 04JUL2014 | Harrisburg, PA 17105-3608 |
| MATERIAL: | | FINISH: | | NAME: Ocean Side Feed Applicator | | RESTRICTED TO: | |
| Customer Accessible Production Drawing | | SCALE: 1:2 | | SIZE: A1 00779 C=2266394 | | SHEET 4 OF 4 REV A | |

Mouser Electronics

Authorized Distributor

Click to View Pricing, Inventory, Delivery & Lifecycle Information:

[TE Connectivity:](#)

[2266394-1](#)