

PART NUMBER	REVISION	DESCRIPTION	FEED TYPE
2266247-1	E	FINE CRIMP HEIGHT ADJUST	MECHANICAL
2266247-2	E	FINE CRIMP HEIGHT ADJUST	PNEUMATIC
7-2266247-1	E	MECHANICAL AND CRIMP TOOLING KIT	MECHANICAL
7-2266247-2	E	PNEUMATIC AND CRIMP TOOLING KIT	PNEUMATIC
7-2266247-7	A	CRIMP TOOLING KIT	-

ATLANTIC VERSION TERMINATOR INTERFACE ADAPTER

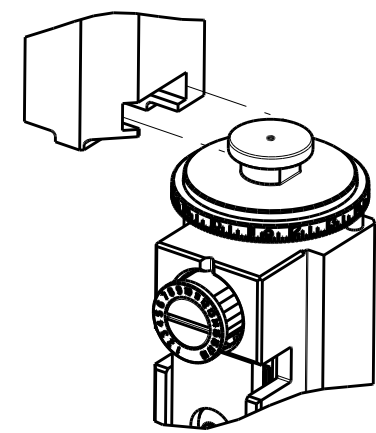

APPLICATOR DATA		
CRIMP	SIZE	TYPE
WIRE	1.78 mm [.070]	F
INSUL	2.03 mm [.080]	F

APPLICATOR INSTRUCTIONS  
408-35042

TERMINAL DATA: TE TERMINAL				TE CRIMP SPECIFICATION			
TERMINAL NAME: NEXT GENERATION 1.50mm MALE TERMINAL							
WIRE STRIP LENGTH		INSULATION DIAMETER RANGE		WIRE STRIP LENGTH		INSULATION DIAMETER RANGE	
5.05-6.60 mm [.199-.260 IN]		Ø1.40-2.13 mm [.055-.084 IN]		5.05-6.60 mm [.199-.260 IN]		Ø1.40-2.13 mm [.055-.084 IN]	
TERMINAL APPLICATION SPECIFICATION		(A)114-13133		TERMINAL APPLICATION SPECIFICATION		(B)114-13091	
TERMINALS APPLIED							
TE TERMINAL	TE TERMINAL	TE TERMINAL	TE TERMINAL	TE TERMINAL	TE TERMINAL	TE TERMINAL	TE TERMINAL
(A) 1488657-2							

TERMINAL DATA: TE TERMINAL				TE CRIMP SPECIFICATION			
TERMINAL NAME: CONTACT, FEMALE, 1.5mm							
WIRE STRIP LENGTH		INSULATION DIAMETER RANGE		WIRE STRIP LENGTH		INSULATION DIAMETER RANGE	
5.05-6.60 mm [.199-.260 IN]		Ø1.40-2.13 mm [.055-.084 IN]		5.05-6.60 mm [.199-.260 IN]		Ø1.40-2.13 mm [.055-.084 IN]	
TERMINAL APPLICATION SPECIFICATION		(A)114-13133		TERMINAL APPLICATION SPECIFICATION		(B)114-13091	
TERMINALS APPLIED							
TE TERMINAL	TE TERMINAL	TE TERMINAL	TE TERMINAL	TE TERMINAL	TE TERMINAL	TE TERMINAL	TE TERMINAL
(B) 638652-2							

WIRE SIZE	CRIMP HEIGHT mm [INCH]	CRIMP HEIGHT REFERENCE SETTING
18 AWG OR 0.75mm2	1.13+/-0.05 [.044+/- .002]	9.7
20 AWG OR 0.50mm2	1.03+/-0.05 [.041+/- .002]	10.8

WIRE SIZE	CRIMP HEIGHT mm [INCH]	CRIMP HEIGHT REFERENCE SETTING
1.00mm2	1.16+/-0.05 [.046+/- .002]	9.1
18 AWG OR 0.75mm2	1.13+/-0.05 [.044+/- .002]	9.7
20 AWG OR 0.50mm2	1.03+/-0.05 [.041+/- .002]	10.8

- 1. RECOMMENDED SPARE PARTS
- 2. REFER TO SUPPLIED INSTRUCTION SHEET FOR CLEANING, LUBRICATION AND STORAGE OF APPLICATOR.
- 3. APPLY PART NUMBER 2-23419-6 LOCTITE TO THREADS OF ITEM 242.
- 4. CRIMP HEIGHT REFERENCE SETTING WAS THE SETTING USED WHEN THE APPLICATOR WAS QUALIFIED AT THE FACTORY. ADJUSTMENT MAY BE NECESSARY WHEN RUNNING APPLICATOR IN THE FIELD.
- 5. UNLESS SPECIFIED OTHERWISE TORQUE VALUES SHALL BE USED PER DOCUMENT, 101-35000.

\*WARNING  
ON INSTALLATION, SET WIRE DISC TO CRIMP HEIGHT REFERENCE SETTING FOR LARGEST WIRE SIZE. CRIMP HEIGHT REFERENCE SETTINGS GREATER THAN THE VALUE SHOWN MAY CAUSE DAMAGE TO THE CRIMP TOOLING, REFER TO THE INSTRUCTION SHEET FOR PROPER SETUP AND ADJUSTMENTS.

ATLANTIC VERSION  
Shown on sheets 1 of 4 & 2 of 4  
(Pacific version shown on sheets 3 of 4 & 4 of 4)

LOC	DIST	REV	LTN	DESCRIPTION	DATE	OWN	APVD
A	66	B		ECR-18-009930	26JUN2018	MEH	TE
		C		ECR-19-005353	03APR2019	FL	GB
		D		ECR-19-011509	22JUL2019	JAH	TE
		E		ECR-20-006086	27APR2020	MZ	YY

-	2	2	2	2	2168083-1	SCR, SKT HD CAP, RoHS, M3 X 8.0	269	
-	1	1	1	1	1633782-2	FENCE	267	
-	1	-	1	-	2119641-1	FEED CAM, AIR FEED	248	
-	1	1	1	1	2119082-5	CAM, SNAIL, INSULATION ADJUSTMENT	244	
-	1	1	1	1	2079764-1	WASHER, WAVE SPRING, CREST-TO-CREST	243	
-	1	1	1	1	2119083-1	RETAINER, INSULATION DIAL	242	
-	1	1	1	1	7-18023-7	SCR, SKT HD CAP M3 X 4.0	241	
-	-	1	-	1	2119580-1	MECHANICAL FEED ASSEMBLY	239	
-	1	-	1	-	2844940-1	AIR FEED MODULE	238	
-	REF	REF	REF	REF	994970-2	COUNTER, MAGNETIC	164	
-	1	1	1	1	2844908-1	SCREW, LOCKING	99	
-	1	1	1	1	2844907-1	POST, LOCKING	98	
-	1	1	1	1	455888-5	SPACER, CRIMPER	82	
-	1	1	1	1	1803607-3	DOCUMENTATION PACKAGE	71	
-	1	1	1	1	2119740-1	TAG, IDENTIFICATION	67	
-	2	2	2	2	2168078-1	SCREW, DRIVE, RH, RoHS, 2 x .188	66	
-	1	1	1	1	2168083-2	SCR, SKT HD CAP, RoHS, M4 X 8.0	60	
-	1	1	1	1	5-18022-5	SCR, HEX HD CAP, M4 X 6.0	59	
-	1	1	1	1	1338685-1	PAWL, FEED	56	
-	4	4	4	4	2168083-3	SCR, SKT HD CAP, RoHS, M4 X 12.0	54	
-	2	2	2	2	2168083-3	SCR, SKT HD CAP, RoHS, M4 X 12.0	53	
-	1	1	1	1	5018030-1	NUT, HEX, REG, RoHS, M3	52	
-	1	1	1	1	811242-5	BUMPER, HOLD DOWN	51	
-	1	1	1	1	690753-2	SPACER, TONKER	50	
-	1	2	1	2	18023-9	SCR, SKT HD CAP M4 X 6.0	49	
-	-	1	-	1	2119652-1	FEED CAM, PRE FEED	48	
-	-	1	-	1	2119653-1	FEED CAM, POST FEED	47	
-	1	1	1	1	1803583-9	APPLICATOR BASIC ASSEMBLY, SF	46	
-	1	1	1	1	1803515-1	RAM ASSEMBLY, SF ATLANTIC	44	
-	1	1	1	1	1803602-1	SCR, BHSC, RoHS (M8 X 25)	41	
-	1	1	1	1	2-1752356-0	SUPPORT, TERMINAL	34	
-	2	2	2	2	2079383-5	SCR, BHSC, RoHS (M4 X 20)	33	
-	2	2	2	2	2-2844962-8	SPACER, CYLINDRICAL, STRIP GUIDE	30	
-	1	1	1	1	2844992-2	ASSEMBLY, STRIP GUIDE	29	
-	1	1	1	1	455888-3	SPACER, CRIMPER	28	
-	1	1	1	1	1320928-6	STRIP GUIDE	24	
-	1	1	1	1	2168083-2	SCR, SKT HD CAP, RoHS, M4 X 8.0	21	
-	2	2	2	2	1-18028-2	WASHER, FLAT, REG M4	20	
-	1	1	1	1	2119533-1	STRIPPER, SIDE FEED	19	
-	1	1	1	1	2119806-1	INSERT, SHEAR	13	
-	1	1	1	1	3-22280-3	SPRING, COMPRESSION	12	
-	1	1	1	1	1-356885-4	STOP, SHEAR	11	
-	1	1	1	1	2119805-1	SHEAR HOLDER, FRONT	10	
-	1	1	1	1	1803095-1	FLOATING SHEAR, FRONT	9	
-	1	2	2	1	1	2-1633919-7	ANVIL, COMBINATION	8
-	1	1	1	1	2-240641-1	SPACER	7	
-	-	-	-	-	-	-	6	
-	1	1	1	1	2119757-8	DEPRESSOR, SHEAR	5	
-	1	1	1	1	238011-2	BLOCK, CRIMPER SPACER	4	
-	1	2	2	1	1	1-1803017-5	CRIMPER, INSULATION F	3
-	1	1	1	1	455888-2	SPACER, CRIMPER	2	
-	1	2	2	1	1	7-456404-2	CRIMPER, WIRE PREMIUM	1
-	77	-72	-71	-2	-1	PART NO	ITEM NO	
							DESCRIPTION	

DIMENSIONS:		TOLERANCES UNLESS OTHERWISE SPECIFIED:		MATERIAL:		FINISH:	
mm	0 PLC ±	1 PLC ±	2 PLC ±	3 PLC ±	4 PLC ±	ANGLES ±	
				WEIGHT		SCALE	
				Customer Accessible Production Drawing		SCALE 1:2 SHEET 1 OF 4 REV E	

LOC	DIST	REV	DATE	BY	APPD
A	66				

# FEED TYPE MECHANICAL

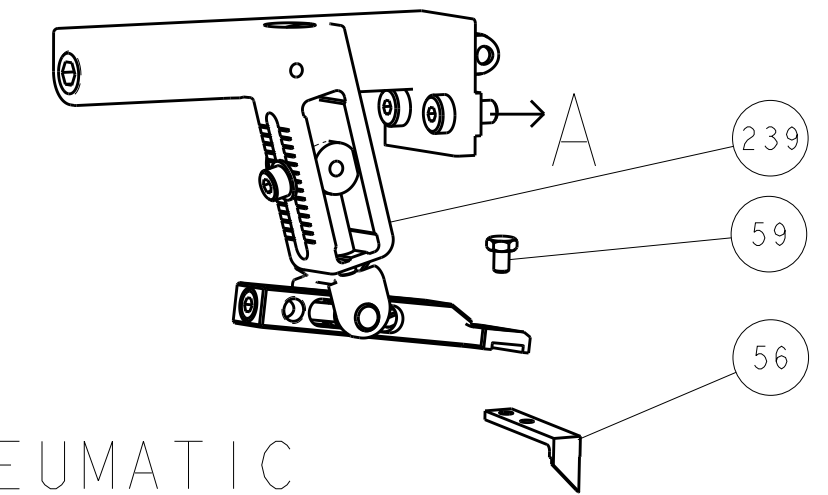

## PNEUMATIC

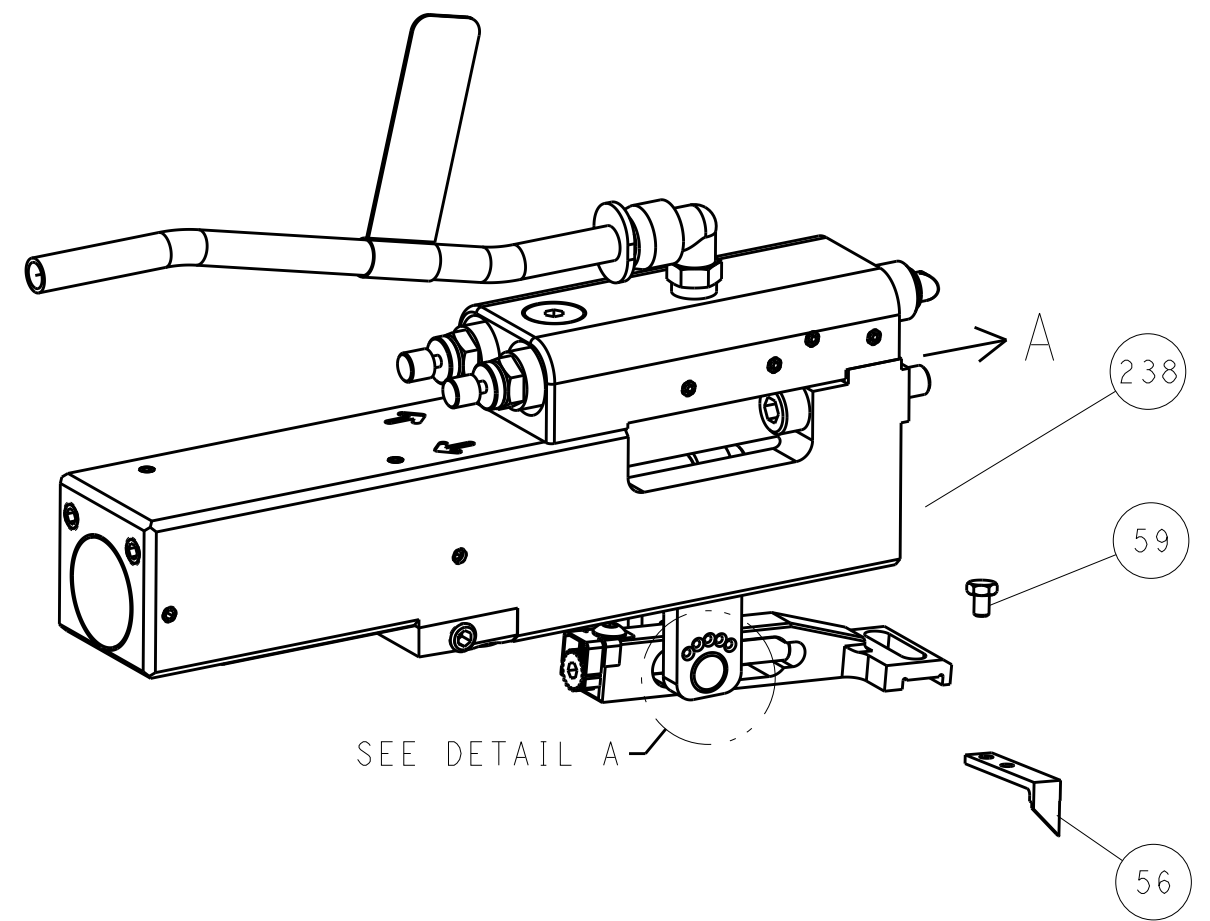

## FEED SPRING SETTING POSITION (SHOWN FROM REAR SIDE)

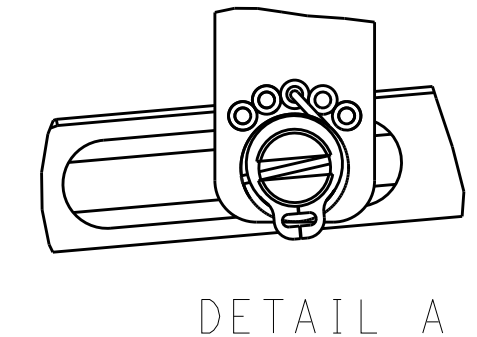

DETAIL A

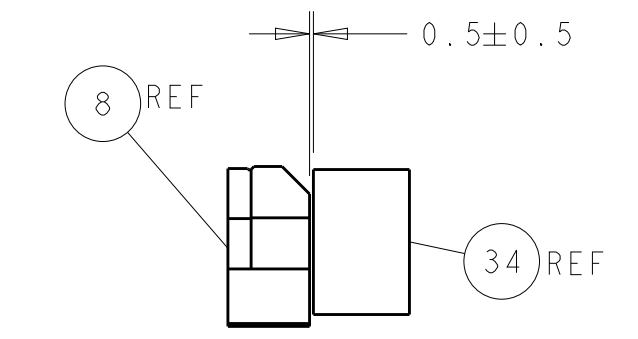
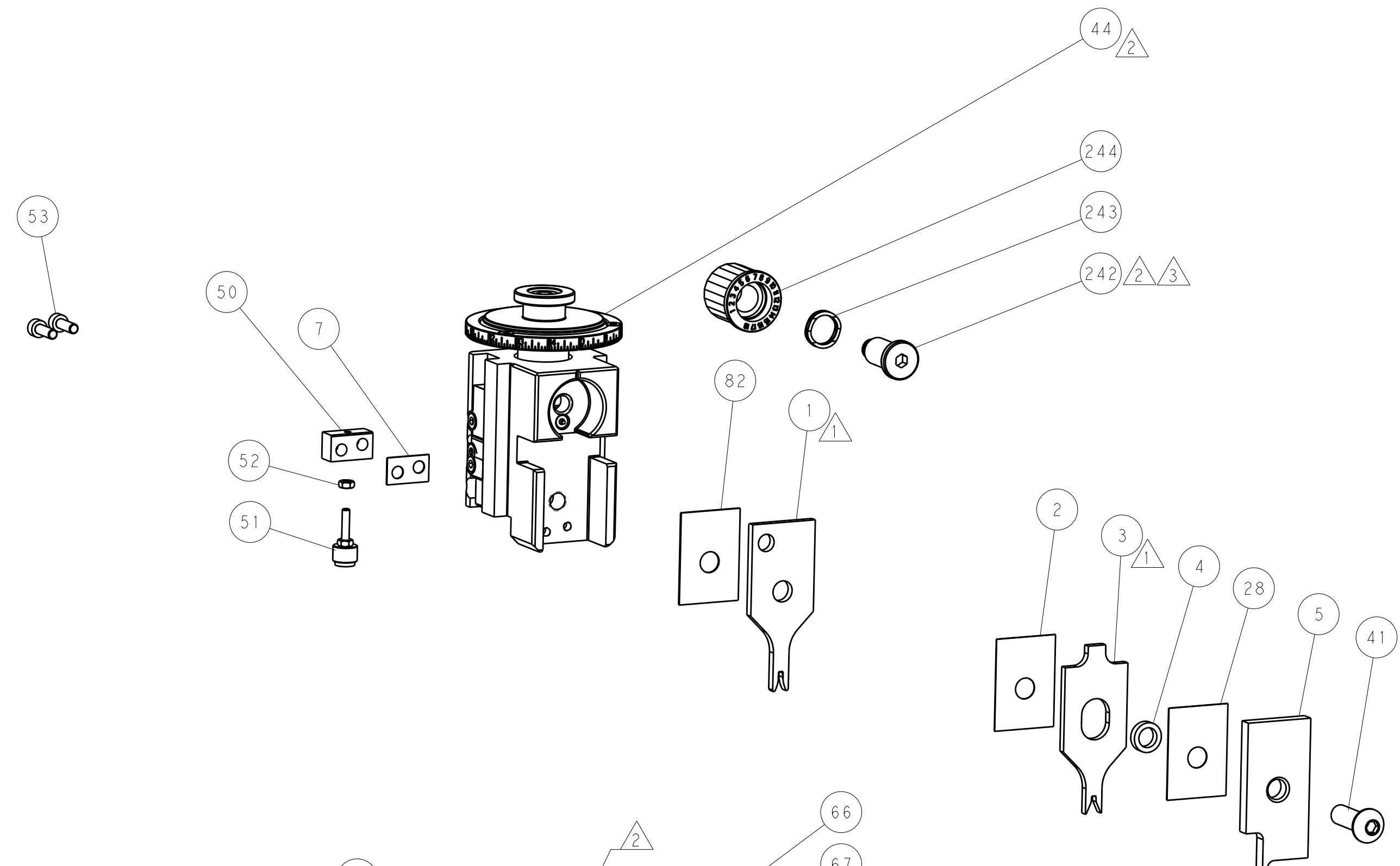

TERMINAL SUPPORT LOCATION

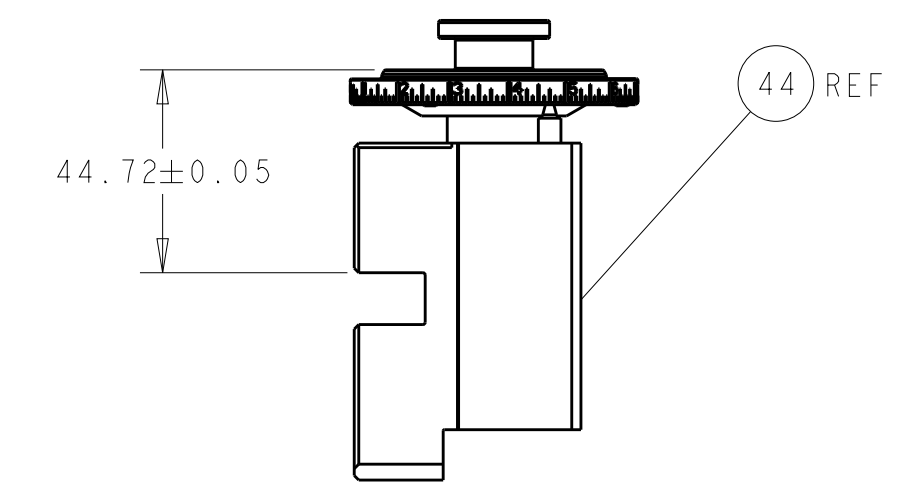

RAM SET-UP

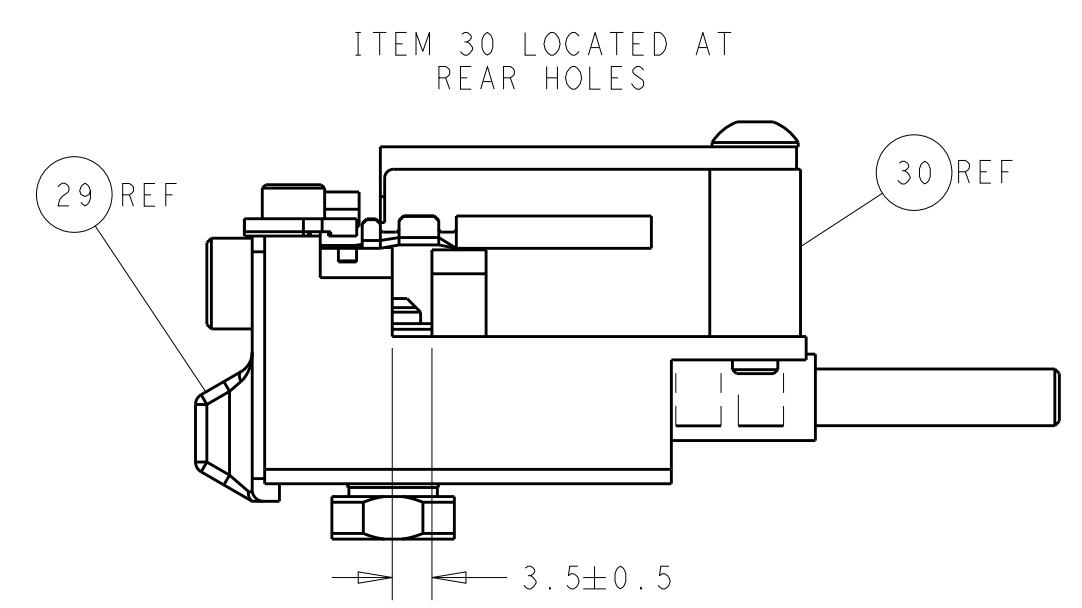
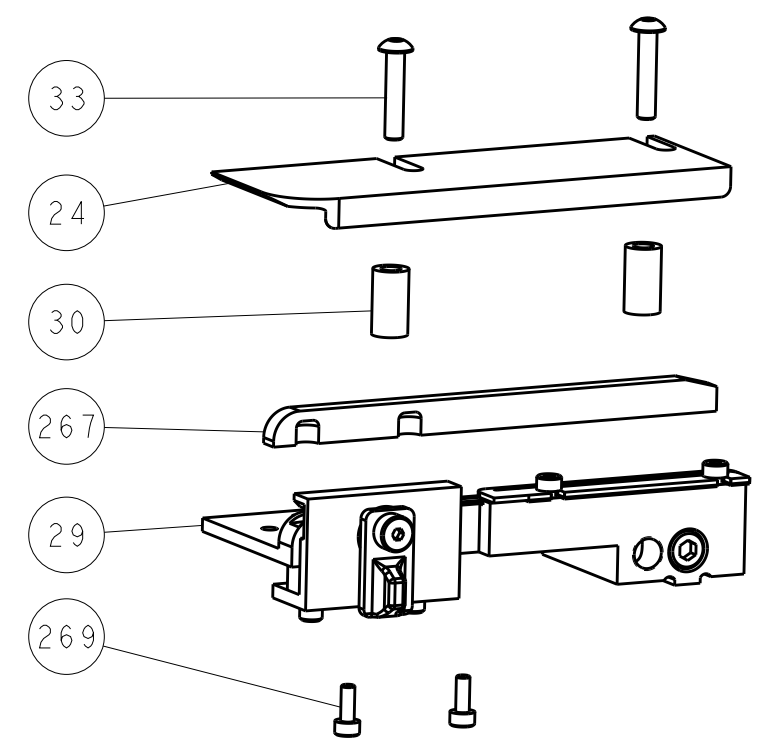

FEED TRACK POSITION GUIDE BY INSULATION BARREL

# CAM POSITIONS

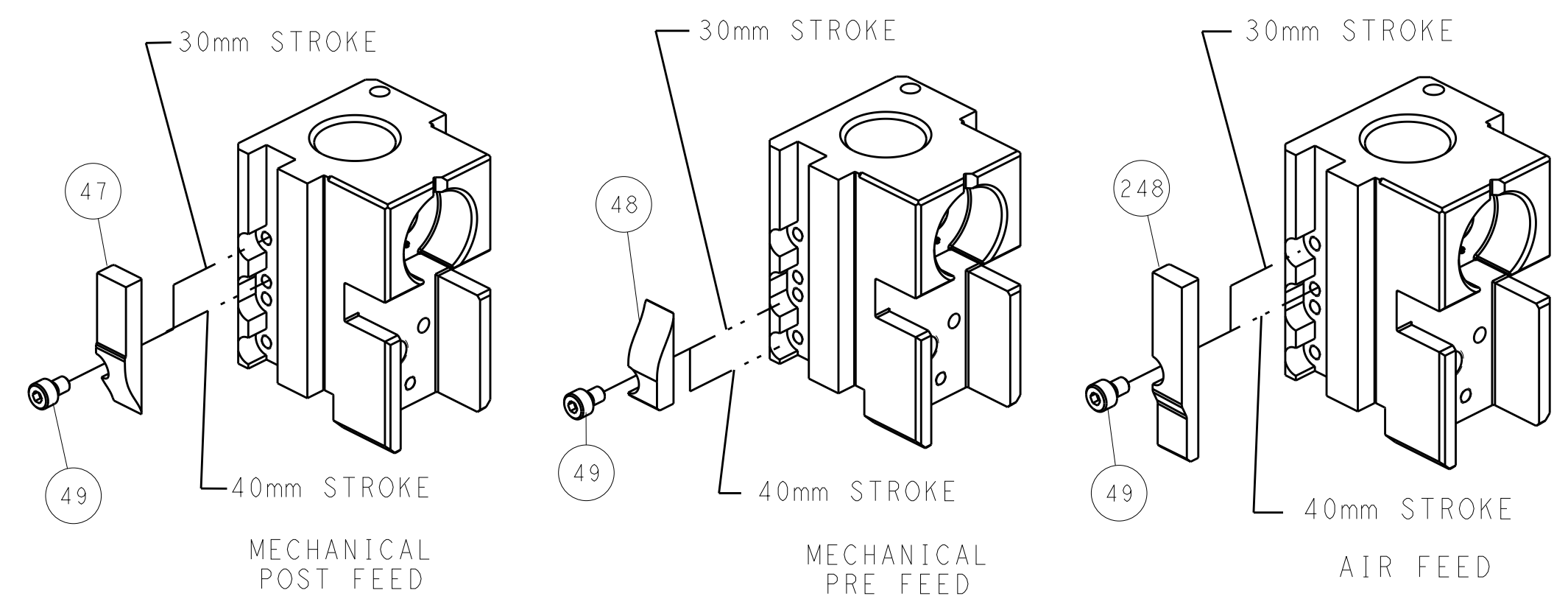

**ATLANTIC VERSION**  
 Shown on sheets 1 of 4 & 2 of 4  
 (Pacific version shown on sheets 3 of 4 & 4 of 4)

DIMENSIONS:		TOLERANCES UNLESS OTHERWISE SPECIFIED:		DWG: R. O. WILSON 03JUN2014		TE Connectivity	
mm	0 PLC ±	1 PLC ±	2 PLC ±	3 PLC ±	4 PLC ±	5 PLC ±	Harrisburg, PA 17105-3608
	ANGLES	FINISH		CHK: G. J. HOFFNER 04JUN2014		NAME: Ocean Side Feed Applicator	
MATERIAL:				APVD: G. E. BAILEY 04JUN2014		SIZE: CAGE CODE: DRAWING NO: A1 00779 ©=2266247	
Customer Accessible Production Drawing				SCALE: 1:2		SHEET 2 OF 4 REV E	

PART NUMBER	REVISION	DESCRIPTION	FEED TYPE
2-2266247-1	E	FINE CRIMP HEIGHT ADJUST	MECHANICAL
2-2266247-2	E	FINE CRIMP HEIGHT ADJUST	PNEUMATIC
7-2266247-7	A	CRIMP TOOLING KIT	-

PACIFIC VERSION TERMINATOR  
INTERFACE ADAPTER



APPLICATOR DATA		
CRIMP	SIZE	TYPE
WIRE	1.78 mm [.070]	F
INSUL	2.03 mm [.080]	F
APPLICATOR INSTRUCTIONS 408-35042		

TERMINAL DATA: TE TERMINAL		TE CRIMP SPECIFICATION	
TERMINAL NAME: NEXT GENERATION 1.50mm MALE TERMINAL			
WIRE STRIP LENGTH		INSULATION DIAMETER RANGE	
5.05-6.60 mm [1.99-.260 IN]		Ø1.40-2.13 mm [.055-.084 IN]	
TERMINAL APPLICATION SPECIFICATION	(A)114-13133	-	-
TERMINALS APPLIED			
TE TERMINAL	TE TERMINAL	TE TERMINAL	TE TERMINAL
(A) 1488657-2			

TERMINAL DATA: TE TERMINAL		TE CRIMP SPECIFICATION	
TERMINAL NAME: CONTACT, FEMALE, 1.5mm			
WIRE STRIP LENGTH		INSULATION DIAMETER RANGE	
5.05-6.60 mm [1.99-.260 IN]		Ø1.40-2.13 mm [.055-.084 IN]	
TERMINAL APPLICATION SPECIFICATION	(B)114-13091	-	-
TERMINALS APPLIED			
TE TERMINAL	TE TERMINAL	TE TERMINAL	TE TERMINAL
(B) 638652-2			

WIRE SIZE	CRIMP HEIGHT mm [INCH]	CRIMP HEIGHT REFERENCE SETTING
18 AWG OR 0.75mm2	1.13+/-0.05 [.044+/- .002]	9.7
20 AWG OR 0.50mm2	1.03+/-0.05 [.041+/- .002]	10.8

WIRE SIZE	CRIMP HEIGHT mm [INCH]	CRIMP HEIGHT REFERENCE SETTING
1.00mm2	1.16+/-0.05 [.046+/- .002]	9.1
18 AWG OR 0.75mm2	1.13+/-0.05 [.044+/- .002]	9.7
20 AWG OR 0.50mm2	1.03+/-0.05 [.041+/- .002]	10.8

- RECOMMENDED SPARE PARTS
- REFER TO SUPPLIED INSTRUCTION SHEET FOR CLEANING, LUBRICATION AND STORAGE OF APPLICATOR.
- APPLY PART NUMBER 2-23419-6 LOCTITE TO THREADS OF ITEM 242.
- CRIMP HEIGHT REFERENCE SETTING WAS THE SETTING USED WHEN THE APPLICATOR WAS QUALIFIED AT THE FACTORY. ADJUSTMENT MAY BE NECESSARY WHEN RUNNING APPLICATOR IN THE FIELD.
- 5. UNLESS SPECIFIED OTHERWISE TORQUE VALUES SHALL BE USED PER DOCUMENT, 101-35000.

**\*WARNING**  
ON INSTALLATION, SET WIRE DISC TO CRIMP HEIGHT REFERENCE SETTING FOR LARGEST WIRE SIZE. CRIMP HEIGHT REFERENCE SETTINGS GREATER THAN THE VALUE SHOWN MAY CAUSE DAMAGE TO THE CRIMP TOOLING, REFER TO THE INSTRUCTION SHEET FOR PROPER SETUP AND ADJUSTMENTS.

PACIFIC VERSION  
Shown on sheets 3 of 4 & 4 of 4  
(Atlantic version shown on sheets 1 of 4 & 2 of 4)

LOC	DIST	REV	DATE	BY	APPD
A	66	-	-	-	-

REV	DATE	BY	APPD	DESCRIPTION	ITEM NO	
-	2	2		2168083-1 SCR, SKT HD CAP, RoHS, M3 X 8.0	269	
-	1	1		1633782-2 FENCE	267	
-	1	1		2119082-5 CAM, SNAIL, INSULATION ADJUSTMENT	244	
-	1	1		2079764-1 WASHER, WAVE SPRING, CREST-TO-CREST	243	
-	1	1		2119083-1 RETAINER, INSULATION DIAL	242	
-	1	1		7-18023-7 SCR, SKT HD CAP M3 X 4.0	241	
-	-	1		2119580-1 MECHANICAL FEED ASSEMBLY	239	
-	1	-		2844940-1 AIR FEED MODULE	238	
-	REF	REF		994970-2 COUNTER, MAGNETIC	164	
-	1	-		2119641-2 FEED CAM, AIR FEED	151	
-	1	1		2168083-8 SCR, SKT HD CAP, RoHS, M4 X 16	144	
-	4	4		2168083-9 SCR, SKT HD CAP, RoHS, M4 X 20	143	
-	-	1		2119653-2 FEED CAM, POST FEED	142	
-	1	1		1-1803583-0 APPLICATOR BASIC ASSEMBLY, SF	141	
-	1	1		1803516-1 RAM ASSEMBLY, SF PACIFIC	140	
-	1	1		2844908-1 SCREW, LOCKING	99	
-	1	1		2844907-1 POST, LOCKING	98	
-	1	1		455888-5 SPACER, CRIMPER	82	
-	1	1		1803607-3 DOCUMENTATION PACKAGE	71	
-	1	1		2119740-1 TAG, IDENTIFICATION	67	
-	2	2		2168078-1 SCREW, DRIVE, RH, RoHS, 2 x .188	66	
-	1	1		5-18022-5 SCR, HEX HD CAP, M4 X 6.0	59	
-	1	1		1338685-1 PAWL, FEED	56	
-	2	2		2168083-3 SCR, SKT HD CAP, RoHS, M4 X 12.0	53	
-	1	1		5018030-1 NUT, HEX, REG, RoHS, M3	52	
-	1	1		811242-5 BUMPER, HOLD DOWN	51	
-	1	1		690753-2 SPACER, TONKER	50	
-	1	2		18023-9 SCR, SKT HD CAP M4 X 6.0	49	
-	-	1		2119652-1 FEED CAM, PRE FEED	48	
-	1	1		1803602-1 SCR, BHSC, RoHS (M8 X 25)	41	
-	1	1		2-1752356-0 SUPPORT, TERMINAL	34	
-	2	2		2079383-5 SCR, BHSC, RoHS (M4 X 20)	33	
-	2	2		2-2844962-8 SPACER, CYLINDRICAL, STRIP GUIDE	30	
-	1	1		2844992-2 ASSEMBLY, STRIP GUIDE	29	
-	1	1		455888-3 SPACER, CRIMPER	28	
-	1	1		1320928-6 STRIP GUIDE	24	
-	1	1		2168083-2 SCR, SKT HD CAP, RoHS, M4 X 8.0	21	
-	2	2		1-18028-2 WASHER, FLAT, REG M4	20	
-	1	1		2119533-1 STRIPPER, SIDE FEED	19	
-	1	1		2119806-1 INSERT, SHEAR	13	
-	1	1		3-22280-3 SPRING, COMPRESSION	12	
-	1	1		1-356885-4 STOP, SHEAR	11	
-	1	1		2119805-1 SHEAR HOLDER, FRONT	10	
-	1	1		1803095-1 FLOATING SHEAR, FRONT	9	
-	1	1		2-1633919-7 ANVIL, COMBINATION	8	
-	1	1		2-240641-1 SPACER	7	
-	-	-		-	6	
-	1	1		2119757-8 DEPRESSOR, SHEAR	5	
-	1	1		238011-2 BLOCK, CRIMPER SPACER	4	
-	1	1		1-1803017-5 CRIMPER, INSULATION F	3	
-	1	1		455888-2 SPACER, CRIMPER	2	
-	1	1		7-456404-2 CRIMPER, WIRE PREMIUM	1	
-77	-22	-21		PART NO	DESCRIPTION	ITEM NO

DIMENSIONS:		TOLERANCES UNLESS OTHERWISE SPECIFIED:		DWG: R.O. WILSON 03JUN2014		CHK: G. J. HOFFNER 04JUN2014		APVD: G. E. BALLEY 04JUN2014		NAME: Ocean Side Feed Applicator	
mm	0 PLC ±	1 PLC ±	2 PLC ±	3 PLC ±	4 PLC ±	ANGLES ±	FINISH	WEIGHT	SCALE: 1:2	SHEET: 3 OF 4	REV: E
MATERIAL:								Customer Accessible Production Drawing		RESTRICTED TO:	

LOC		DIST		REVISIONS			
A	66	P	LTM	DESCRIPTION	DATE	OWN	APVD
		-		SEE SHEET 1			

# FEED TYPE MECHANICAL

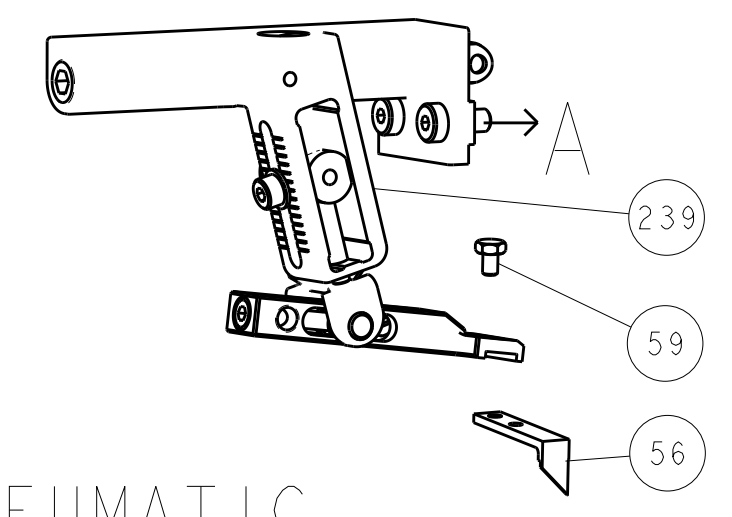

## PNEUMATIC

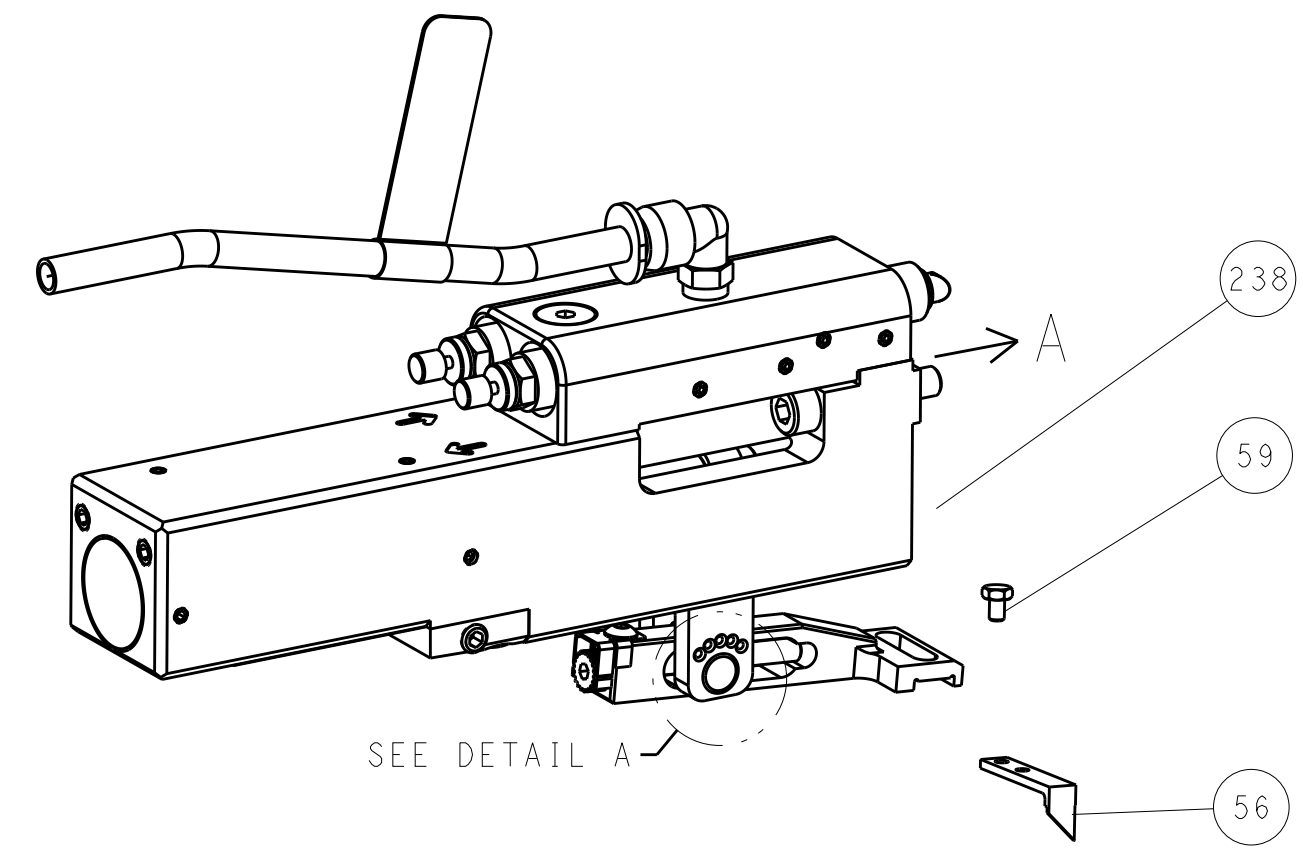

## FEED SPRING SETTING POSITION (SHOWN FROM REAR SIDE)

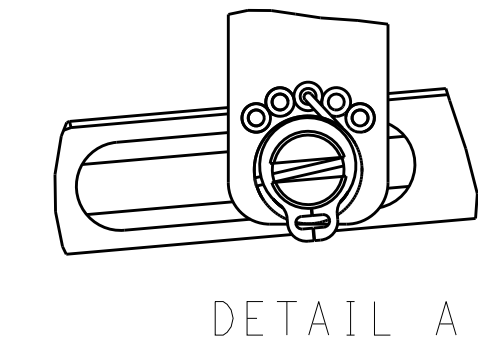

# CAM POSITIONS

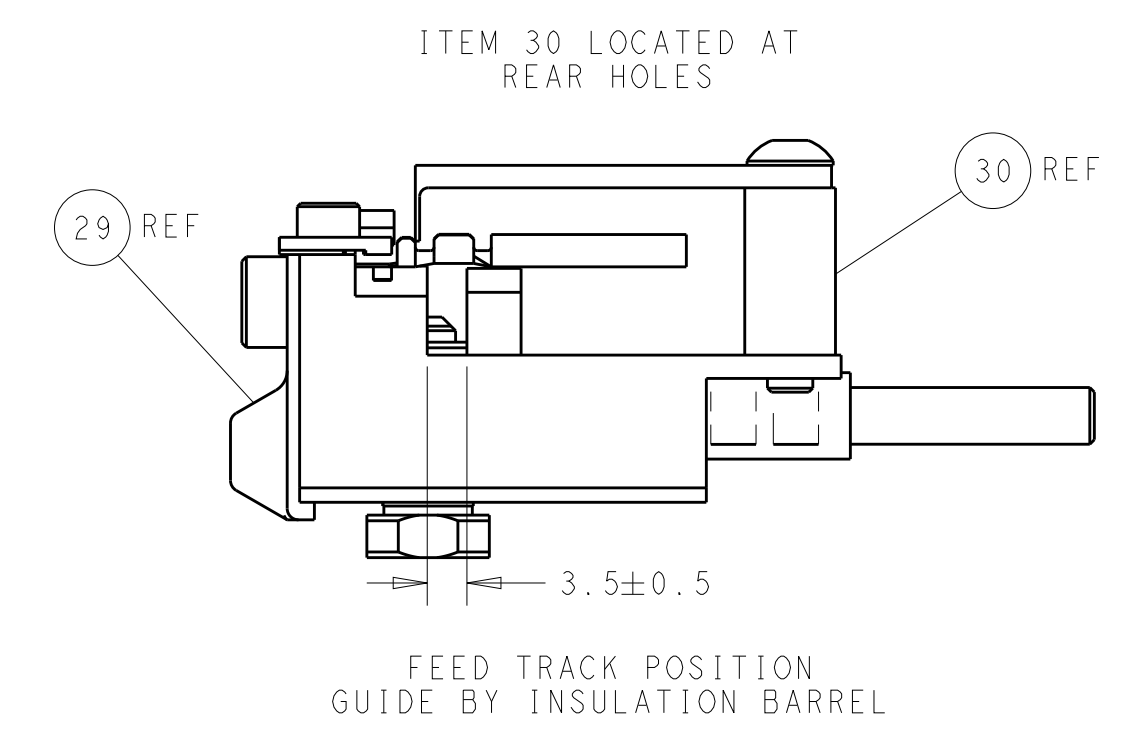
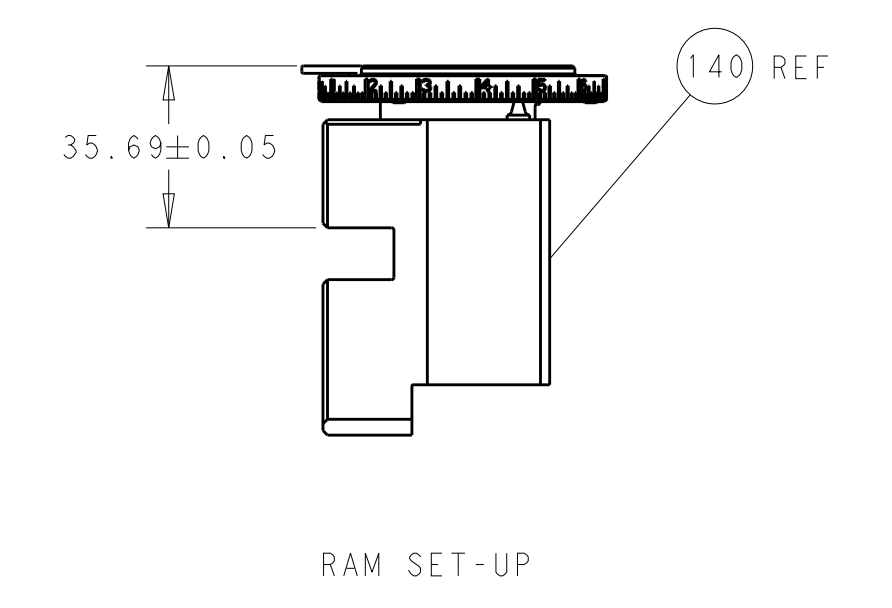
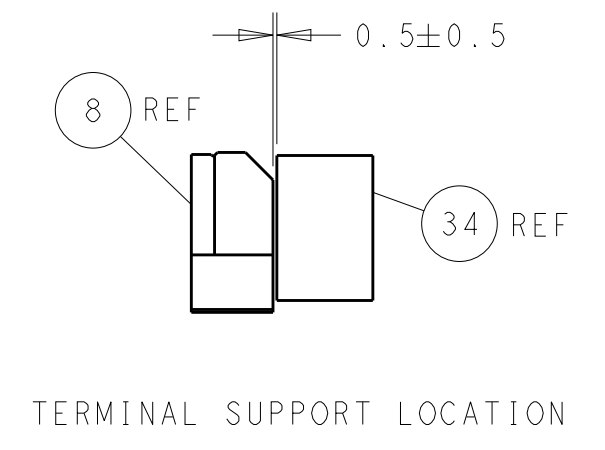
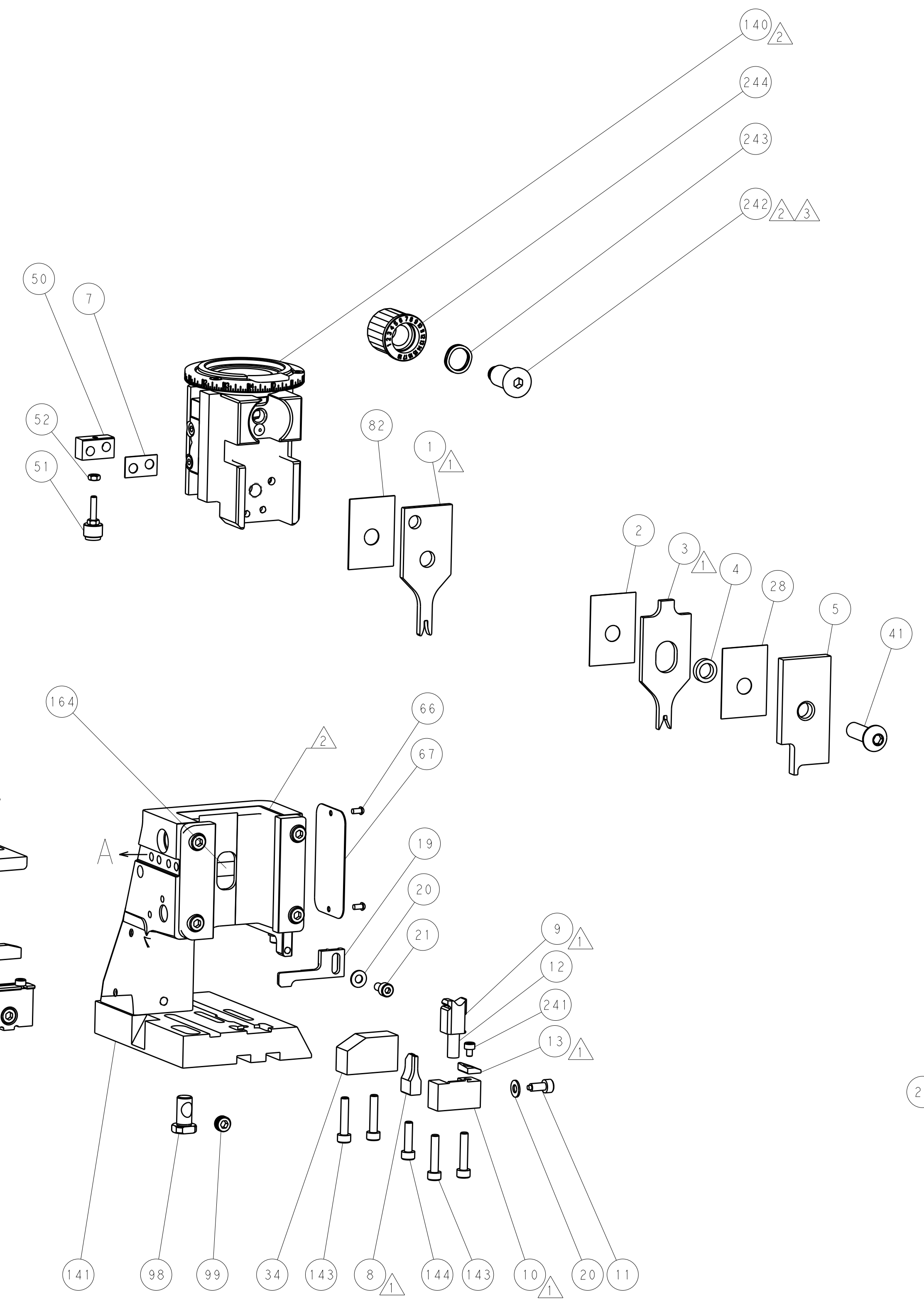
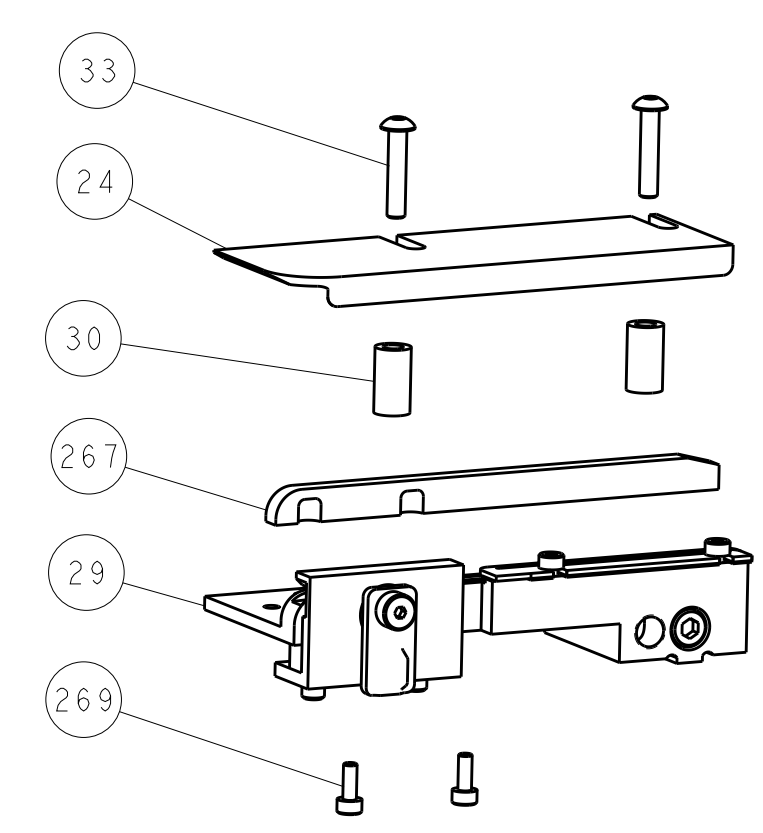
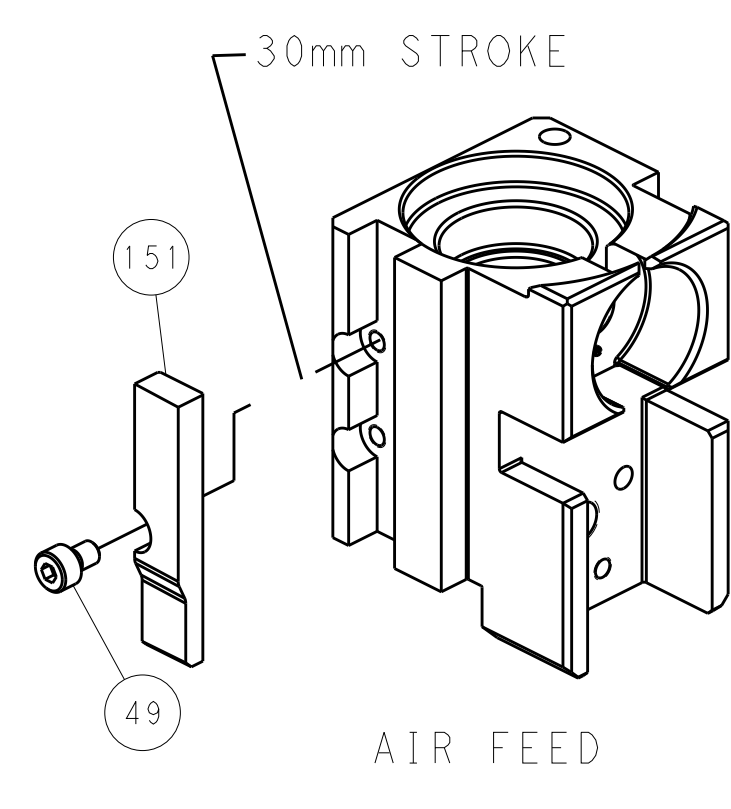
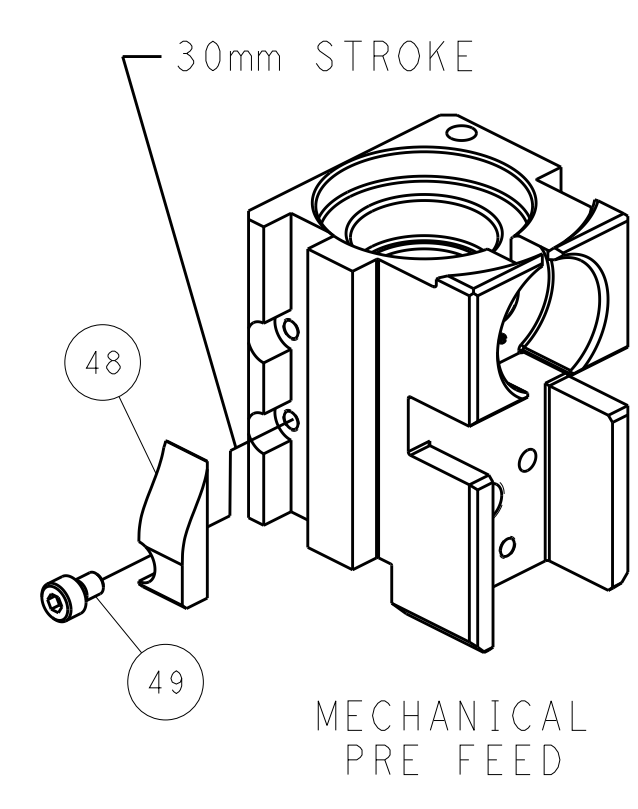
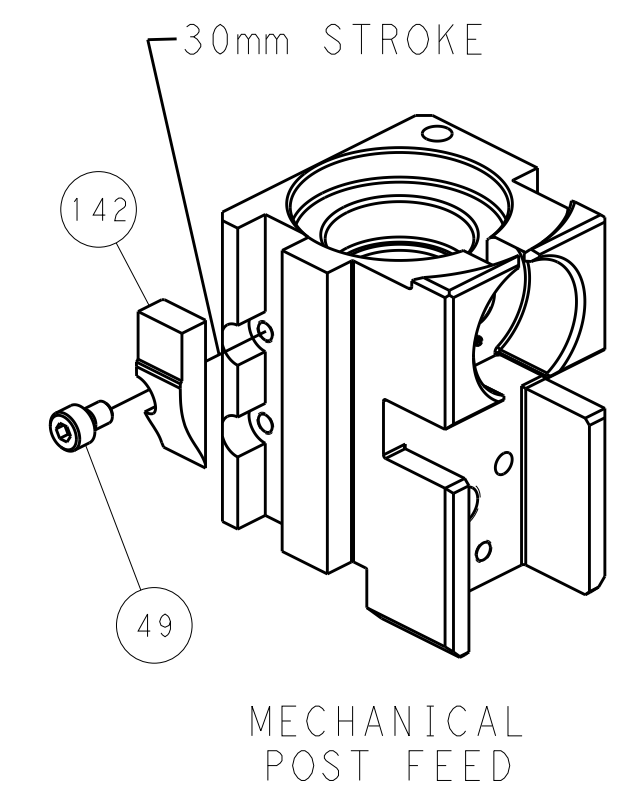

**PACIFIC VERSION**  
 Shown on sheets 3 of 4 & 4 of 4  
 (Atlantic version shown on sheets 1 of 4 & 2 of 4)

DIMENSIONS:		TOLERANCES UNLESS OTHERWISE SPECIFIED:		DWG: R.O. WILSON 03JUN2014		TE Connectivity	
mm	0 PLC ±	1 PLC ±	2 PLC ±	3 PLC ±	4 PLC ±	5 PLC ±	Harrisburg, PA 17105-3608
MATERIAL:		FINISH:		CHK: G. J. HOFFNER 04JUN2014		NAME: Ocean Side Feed Applicator	
				APVD: G. E. BAILEY 04JUN2014		SIZE: CAGE CODE: DRAWING NO: RESTRICTED TO	
				PRODUCT SPEC:		A1 00779 ©=2266247	
				APPLICATION SPEC:		SCALE: 1:2 SHEET 4 OF 4 REV E	
				WEIGHT:		Customer Accessible Production Drawing	

# Mouser Electronics

Authorized Distributor

Click to View Pricing, Inventory, Delivery & Lifecycle Information:

[TE Connectivity:](#)

[2266247-2](#)