

PART NUMBER	REVISION	DESCRIPTION	FEED TYPE
2151606-1	B	FINE CRIMP HEIGHT ADJUST	MECHANICAL
2151606-2	B	FINE CRIMP HEIGHT ADJUST	PNEUMATIC
7-2151606-1	B	MECHANICAL AND CRIMP TOOLING KIT	MECHANICAL
7-2151606-2	B	PNEUMATIC AND CRIMP TOOLING KIT	PNEUMATIC
7-2151606-7	A	CRIMP TOOLING KIT	-

ATLANTIC VERSION TERMINATOR INTERFACE ADAPTER

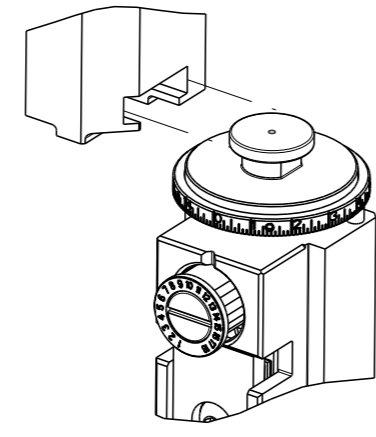

APPLICATOR DATA		
CRIMP	SIZE	TYPE
WIRE	2.54 mm [.100]	F
INSUL	3.94 mm [.155]	F

APPLICATOR INSTRUCTIONS
408-35042

TERMINAL DATA: TE TERMINAL		TE CRIMP SPECIFICATION	
TERMINAL NAME: PIN, .156 MATE-N-LOK			
WIRE STRIP LENGTH		INSULATION DIAMETER RANGE	
4.95-5.72mm [.195-.225 IN]		Ø3.18mm Max [.125 IN]	
TERMINAL APPLICATION SPECIFICATION	114-1109	-	-
TERMINALS APPLIED			
TE TERMINAL	TE TERMINAL	TE TERMINAL	TE TERMINAL
61086-1			

TERMINAL DATA: TE TERMINAL		TE CRIMP SPECIFICATION	
TERMINAL NAME: SOCKET, .156 MATE-N-LOK			
WIRE STRIP LENGTH		INSULATION DIAMETER RANGE	
4.95-5.72mm [.195-.225 IN]		Ø3.18mm Max [.125 IN]	
TERMINAL APPLICATION SPECIFICATION	114-1109	-	-
TERMINALS APPLIED			
TE TERMINAL	TE TERMINAL	TE TERMINAL	TE TERMINAL
61085-1			

WIRE SIZE	CRIMP HEIGHT mm [INCH]	CRIMP HEIGHT REFERENCE SETTING
14 AWG	1.96+/-0.05 [.077+/- .002]	5.5
16 AWG	1.70+/-0.05 [.067+/- .002]	8.5
18 AWG	1.55+/-0.05 [.061+/- .002]	10.0
20 AWG	1.45+/-0.05 [.057+/- .002]	11.1

WIRE SIZE	CRIMP HEIGHT WI_CRIMP_UNITS	CRIMP HEIGHT REFERENCE SETTING
14 AWG	1.96+/-0.05 [.077+/- .002]	5.5
16 AWG	1.70+/-0.05 [.067+/- .002]	8.5
18 AWG	1.55+/-0.05 [.061+/- .002]	10.0
20 AWG	1.45+/-0.05 [.057+/- .002]	11.1

- 1. RECOMMENDED SPARE PARTS
- 2. REFER TO SUPPLIED INSTRUCTION SHEET FOR CLEANING, LUBRICATION AND STORAGE OF APPLICATOR.
- 3. APPLY PART NUMBER 2-23419-6 LOCTITE TO THREADS OF ITEM 242.
- 4. CRIMP HEIGHT REFERENCE SETTING WAS THE SETTING USED WHEN THE APPLICATOR WAS QUALIFIED AT THE FACTORY. ADJUSTMENT MAY BE NECESSARY WHEN RUNNING APPLICATOR IN THE FIELD.
- 5. UNLESS SPECIFIED OTHERWISE TORQUE VALUES SHALL BE USED PER DOCUMENT, 101-35000.

***WARNING**
ON INSTALLATION, SET WIRE DISC TO CRIMP HEIGHT REFERENCE SETTING FOR LARGEST WIRE SIZE. CRIMP HEIGHT REFERENCE SETTINGS GREATER THAN THE VALUE SHOWN MAY CAUSE DAMAGE TO THE CRIMP TOOLING, REFER TO THE INSTRUCTION SHEET FOR PROPER SETUP AND ADJUSTMENTS.

ATLANTIC VERSION
Shown on sheets 1 of 4 & 2 of 4
(Pacific version shown on sheets 3 of 4 & 4 of 4)

LOC	DIST	REVISIONS			
		REV	DATE	BY	APPV
A	66	A	RELEASED	25APR2012	RW TE
		B	ECR-18-009847	25JUN2018	VLA CT

-	1	-	1	-	2119640-1	PUSH ROD, AIR FEED	250
-	1	-	1	-	1803259-1	BUSHING, FLANGED	249
-	1	-	1	-	2119641-1	FEED CAM, AIR FEED	248
-	1	1	1	1	2119082-9	CAM, SNAIL, INSULATION ADJUSTMENT	244
-	1	1	1	1	2079764-1	WASHER, WAVE SPRING, CREST-TO-CREST	243
-	1	1	1	1	2119083-1	RETAINER, INSULATION DIAL	242
-	1	1	1	1	18023-1	SCR, SKT HD CAP M3 X 5.0	241
-	-	1	-	1	2119580-1	MECHANICAL FEED ASSEMBLY	239
-	1	-	1	-	2063440-1	AIR FEED MODULE	238
-	2	-	2	-	21045-3	RING, RETAIN, EXTERN, 3/16 CRESCENT	172
-	REF	REF	REF	REF	994970-2	COUNTER, MAGNETIC	164
-	1	-	1	-	240638-1	SPRING, FEED FINGER	163
-	1	-	1	-	3-23627-7	PIN, RETAIN, GRVD, 3/16 X .854	137
-	1	-	1	-	2119799-1	HOLDER, FEED FINGER, AF	136
-	1	1	1	1	1-18028-2	WASHER, FLAT, REG M4	119
-	1	1	1	1	2844908-1	SCREW, LOCKING	99
-	1	1	1	1	2844907-1	POST, LOCKING	98
-	1	1	1	1	1-455888-2	SPACER, CRIMPER	82
-	1	1	1	1	1803607-1	DOCUMENTATION PACKAGE	71
-	1	1	1	1	2119740-1	TAG, IDENTIFICATION	67
-	2	2	2	2	2168078-1	SCREW, DRIVE, RH, RoHS, 2 x .188	66
-	1	1	1	1	2168083-2	SCR, SKT HD CAP, RoHS, M4 X 8.0	60
-	1	1	1	1	5-18022-5	SCR, HEX HD CAP, M4 X 6.0	59
-	1	1	1	1	1338685-1	PAWL, FEED	56
-	4	4	4	4	2168083-3	SCR, SKT HD CAP, RoHS, M4 X 12.0	54
-	2	2	2	2	1-2168083-0	SCR, SKT HD CAP, RoHS, M4 X 10	53
-	1	1	1	1	1803382-6	HOLD DOWN, SPRING LOADED	50
-	1	2	1	2	18023-9	SCR, SKT HD CAP M4 X 6.0	49
-	-	1	-	1	2119652-1	FEED CAM, PRE FEED	48
-	-	1	-	1	2119653-1	FEED CAM, POST FEED	47
-	1	1	1	1	1803583-9	APPLICATOR BASIC ASSEMBLY, SF	46
-	1	1	1	1	1803515-1	RAM ASSEMBLY, SF ATLANTIC	44
-	1	1	1	1	1803602-1	SCR, BHSC, RoHS (M8 X 25)	41
-	1	1	1	1	1752356-6	SUPPORT, TERMINAL	34
-	2	2	2	2	2079383-5	SCR, BHSC, RoHS (M4 X 20)	33
-	2	2	2	2	2-2844962-8	SPACER, CYLINDRICAL, STRIP GUIDE	30
-	1	1	1	1	2844992-1	ASSEMBLY, STRIP GUIDE	29
-	1	1	1	1	1-455888-0	SPACER, CRIMPER	28
-	1	1	1	1	1320928-2	STRIP GUIDE	24
-	1	1	1	1	2168083-2	SCR, SKT HD CAP, RoHS, M4 X 8.0	21
-	1	1	1	1	1-18028-2	WASHER, FLAT, REG M4	20
-	1	1	1	1	2119533-1	STRIPPER, SIDE FEED	19
-	1	1	1	1	2119806-1	INSERT, SHEAR	13
-	1	1	1	1	3-22280-3	SPRING, COMPRESSION	12
-	1	1	1	1	1-356885-4	STOP, SHEAR	11
-	1	1	1	1	2119805-1	SHEAR HOLDER, FRONT	10
-	1	1	1	1	454276-5	FLOATING SHEAR, FRONT	9
-	1	2	2	1	1633922-4	ANVIL, COMBINATION	8
-	-	-	-	-	-	-	7
-	-	-	-	-	-	-	6
-	1	1	1	1	2119757-8	DEPRESSOR, SHEAR	5
-	1	1	1	1	1-238011-7	BLOCK, CRIMPER SPACER	4
-	1	2	2	1	2-2119582-6	CRIMPER, INSULATION F PREMIUM	3
-	1	1	1	1	455888-5	SPACER, CRIMPER	2
-	1	2	2	1	2-456407-6	CRIMPER, WIRE PREMIUM	1

DIMENSIONS:		TOLERANCES UNLESS OTHERWISE SPECIFIED:		MATERIAL:	
mm	0 PLC ±	1 PLC ±	2 PLC ±	3 PLC ±	4 PLC ±
	5 PLC ±	6 PLC ±	7 PLC ±	8 PLC ±	9 PLC ±
	10 PLC ±	11 PLC ±	12 PLC ±	13 PLC ±	14 PLC ±
	15 PLC ±	16 PLC ±	17 PLC ±	18 PLC ±	19 PLC ±
	20 PLC ±	21 PLC ±	22 PLC ±	23 PLC ±	24 PLC ±
	25 PLC ±	26 PLC ±	27 PLC ±	28 PLC ±	29 PLC ±
	30 PLC ±	31 PLC ±	32 PLC ±	33 PLC ±	34 PLC ±
	35 PLC ±	36 PLC ±	37 PLC ±	38 PLC ±	39 PLC ±
	40 PLC ±	41 PLC ±	42 PLC ±	43 PLC ±	44 PLC ±
	45 PLC ±	46 PLC ±	47 PLC ±	48 PLC ±	49 PLC ±
	50 PLC ±	51 PLC ±	52 PLC ±	53 PLC ±	54 PLC ±
	55 PLC ±	56 PLC ±	57 PLC ±	58 PLC ±	59 PLC ±
	60 PLC ±	61 PLC ±	62 PLC ±	63 PLC ±	64 PLC ±
	65 PLC ±	66 PLC ±	67 PLC ±	68 PLC ±	69 PLC ±
	70 PLC ±	71 PLC ±	72 PLC ±	73 PLC ±	74 PLC ±
	75 PLC ±	76 PLC ±	77 PLC ±	78 PLC ±	79 PLC ±
	80 PLC ±	81 PLC ±	82 PLC ±	83 PLC ±	84 PLC ±
	85 PLC ±	86 PLC ±	87 PLC ±	88 PLC ±	89 PLC ±
	90 PLC ±	91 PLC ±	92 PLC ±	93 PLC ±	94 PLC ±
	95 PLC ±	96 PLC ±	97 PLC ±	98 PLC ±	99 PLC ±
	100 PLC ±	101 PLC ±	102 PLC ±	103 PLC ±	104 PLC ±
	105 PLC ±	106 PLC ±	107 PLC ±	108 PLC ±	109 PLC ±
	110 PLC ±	111 PLC ±	112 PLC ±	113 PLC ±	114 PLC ±
	115 PLC ±	116 PLC ±	117 PLC ±	118 PLC ±	119 PLC ±
	120 PLC ±	121 PLC ±	122 PLC ±	123 PLC ±	124 PLC ±
	125 PLC ±	126 PLC ±	127 PLC ±	128 PLC ±	129 PLC ±
	130 PLC ±	131 PLC ±	132 PLC ±	133 PLC ±	134 PLC ±
	135 PLC ±	136 PLC ±	137 PLC ±	138 PLC ±	139 PLC ±
	140 PLC ±	141 PLC ±	142 PLC ±	143 PLC ±	144 PLC ±
	145 PLC ±	146 PLC ±	147 PLC ±	148 PLC ±	149 PLC ±
	150 PLC ±	151 PLC ±	152 PLC ±	153 PLC ±	154 PLC ±
	155 PLC ±	156 PLC ±	157 PLC ±	158 PLC ±	159 PLC ±
	160 PLC ±	161 PLC ±	162 PLC ±	163 PLC ±	164 PLC ±
	165 PLC ±	166 PLC ±	167 PLC ±	168 PLC ±	169 PLC ±
	170 PLC ±	171 PLC ±	172 PLC ±	173 PLC ±	174 PLC ±
	175 PLC ±	176 PLC ±	177 PLC ±	178 PLC ±	179 PLC ±
	180 PLC ±	181 PLC ±	182 PLC ±	183 PLC ±	184 PLC ±
	185 PLC ±	186 PLC ±	187 PLC ±	188 PLC ±	189 PLC ±
	190 PLC ±	191 PLC ±	192 PLC ±	193 PLC ±	194 PLC ±
	195 PLC ±	196 PLC ±	197 PLC ±	198 PLC ±	199 PLC ±
	200 PLC ±	201 PLC ±	202 PLC ±	203 PLC ±	204 PLC ±
	205 PLC ±	206 PLC ±	207 PLC ±	208 PLC ±	209 PLC ±
	210 PLC ±	211 PLC ±	212 PLC ±	213 PLC ±	214 PLC ±
	215 PLC ±	216 PLC ±	217 PLC ±	218 PLC ±	219 PLC ±
	220 PLC ±	221 PLC ±	222 PLC ±	223 PLC ±	224 PLC ±
	225 PLC ±	226 PLC ±	227 PLC ±	228 PLC ±	229 PLC ±
	230 PLC ±	231 PLC ±	232 PLC ±	233 PLC ±	234 PLC ±
	235 PLC ±	236 PLC ±	237 PLC ±	238 PLC ±	239 PLC ±
	240 PLC ±	241 PLC ±	242 PLC ±	243 PLC ±	244 PLC ±
	245 PLC ±	246 PLC ±	247 PLC ±	248 PLC ±	249 PLC ±
	250 PLC ±	251 PLC ±	252 PLC ±	253 PLC ±	254 PLC ±
	255 PLC ±	256 PLC ±	257 PLC ±	258 PLC ±	259 PLC ±
	260 PLC ±	261 PLC ±	262 PLC ±	263 PLC ±	264 PLC ±
	265 PLC ±	266 PLC ±	267 PLC ±	268 PLC ±	269 PLC ±
	270 PLC ±	271 PLC ±	272 PLC ±	273 PLC ±	274 PLC ±
	275 PLC ±	276 PLC ±	277 PLC ±	278 PLC ±	279 PLC ±
	280 PLC ±	281 PLC ±	282 PLC ±	283 PLC ±	284 PLC ±
	285 PLC ±	286 PLC ±	287 PLC ±	288 PLC ±	289 PLC ±
	290 PLC ±	291 PLC ±	292 PLC ±	293 PLC ±	294 PLC ±
	295 PLC ±	296 PLC ±	297 PLC ±	298 PLC ±	299 PLC ±
	300 PLC ±	301 PLC ±	302 PLC ±	303 PLC ±	304 PLC ±
	305 PLC ±	306 PLC ±	307 PLC ±	308 PLC ±	309 PLC ±
	310 PLC ±	311 PLC ±	312 PLC ±	313 PLC ±	314 PLC ±
	315 PLC ±	316 PLC ±	317 PLC ±	318 PLC ±	319 PLC ±
	320 PLC ±	321 PLC ±	322 PLC ±	323 PLC ±	324 PLC ±
	325 PLC ±	326 PLC ±	327 PLC ±	328 PLC ±	329 PLC ±
	330 PLC ±	331 PLC ±	332 PLC ±	333 PLC ±	334 PLC ±
	335 PLC ±	336 PLC ±	337 PLC ±	338 PLC ±	339 PLC ±
	340 PLC ±	341 PLC ±	342 PLC ±	343 PLC ±	344 PLC ±
	345 PLC ±	346 PLC ±	347 PLC ±	348 PLC ±	349 PLC ±
	350 PLC ±	351 PLC ±	352 PLC ±	353 PLC ±	354 PLC ±
	355 PLC ±	356 PLC ±	357 PLC ±	358 PLC ±	359 PLC ±
	360 PLC ±	361 PLC ±	362 PLC ±	363 PLC ±	364 PLC ±
	365 PLC ±	366 PLC ±	367 PLC ±	368 PLC ±	369 PLC ±
	370 PLC ±	371 PLC ±	372 PLC ±	373 PLC ±	374 PLC ±
	375 PLC ±	376 PLC ±	377 PLC ±	378 PLC ±	379 PLC ±
	380 PLC ±	381 PLC ±	382 PLC ±	383 PLC ±	384 PLC ±
	385 PLC ±	386 PLC ±	387 PLC ±	388 PLC ±	389 PLC ±
	390 PLC ±	391 PLC ±	392 PLC ±	393 PLC ±	394 PLC ±
	395 PLC ±	396 PLC ±	397 PLC ±	398 PLC ±	399 PLC ±
	400 PLC ±	401 PLC ±	402 PLC ±	403 PLC ±	404 PLC ±
	405 PLC ±	406 PLC ±	407 PLC ±	408 PLC ±	409 PLC ±
	410 PLC ±	411 PLC ±	412 PLC ±	413 PLC ±	414 PLC ±
	415 PLC ±	416 PLC ±	417 PLC ±	418 PLC ±	419 PLC ±
	420 PLC ±	421 PLC ±	422 PLC ±	423 PLC ±	424 PLC ±
	425 PLC ±	426 PLC ±	427 PLC ±	428 PLC ±	429 PLC ±
	430 PLC ±	431 PLC ±	432 PLC ±	433 PLC ±	434 PLC ±
	435 PLC ±	436 PLC ±	437 PLC ±	438 PLC ±	439 PLC ±
	440 PLC ±	441 PLC ±	442 PLC ±	443 PLC ±	

LOC	DIST	REVISIONS			
A	66	REV	DATE	OWN	APVD
-	SEE SHEET 1	-	-	-	-

FEED TYPE MECHANICAL

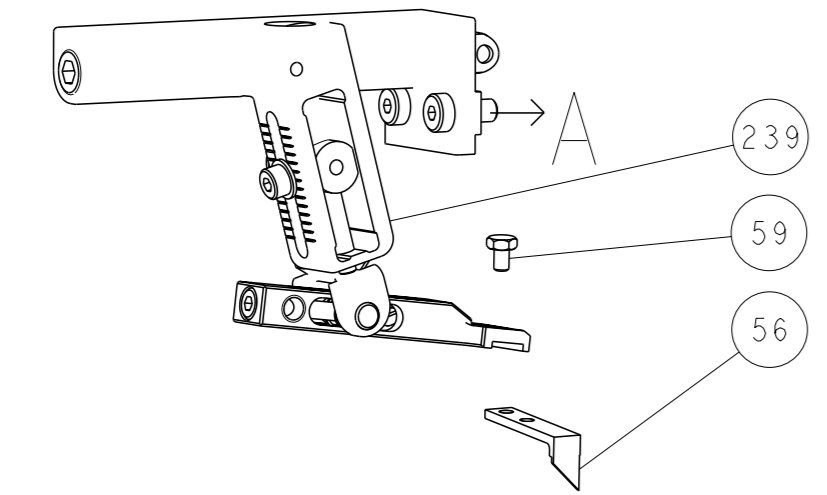

PNEUMATIC

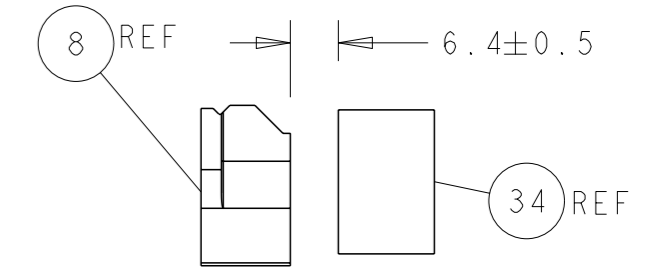
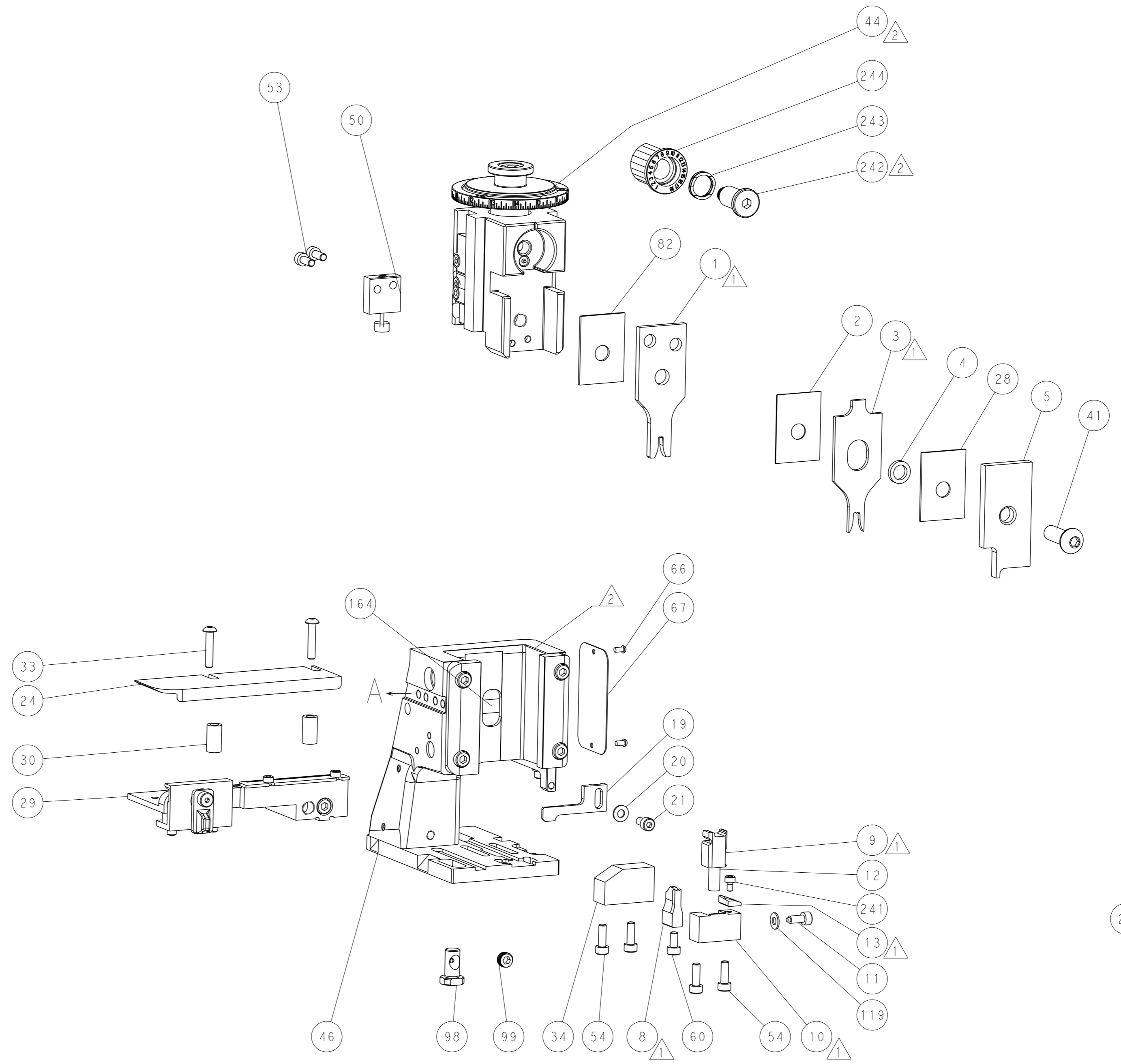
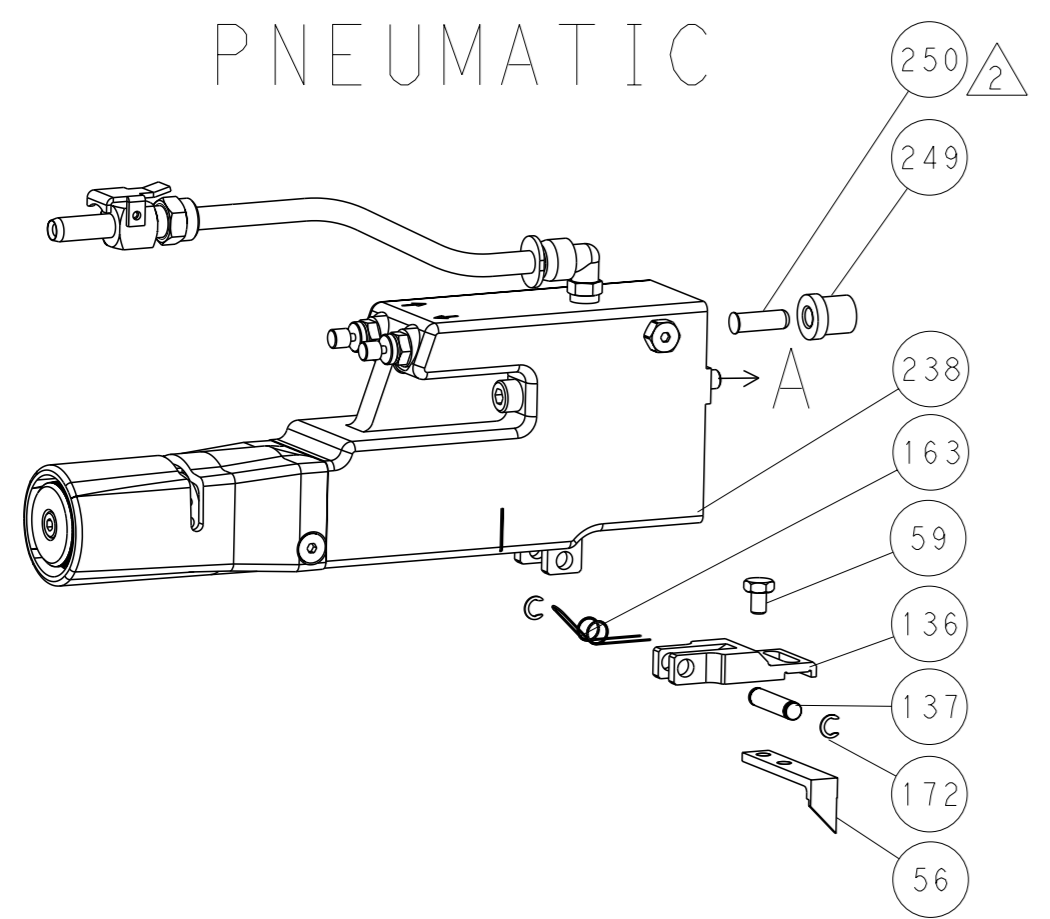

TERMINAL SUPPORT LOCATION

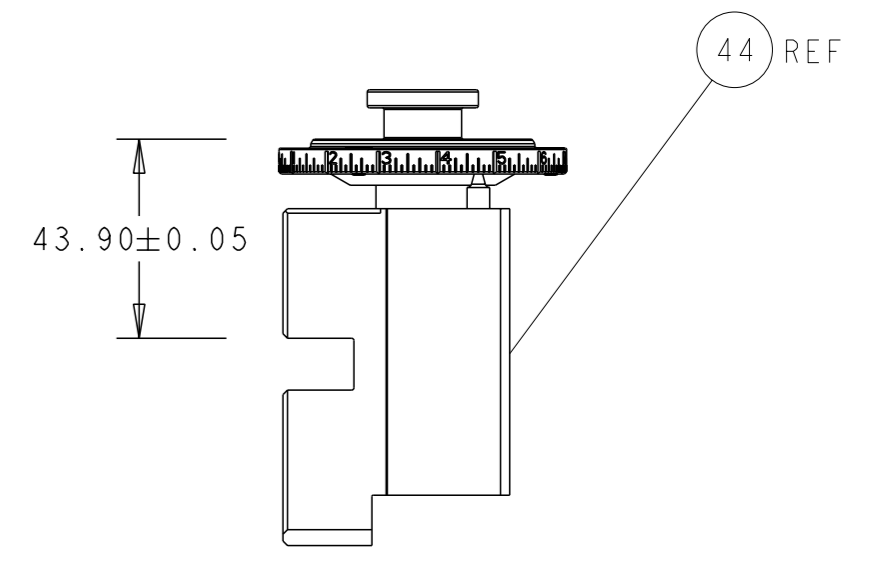

RAM SET-UP

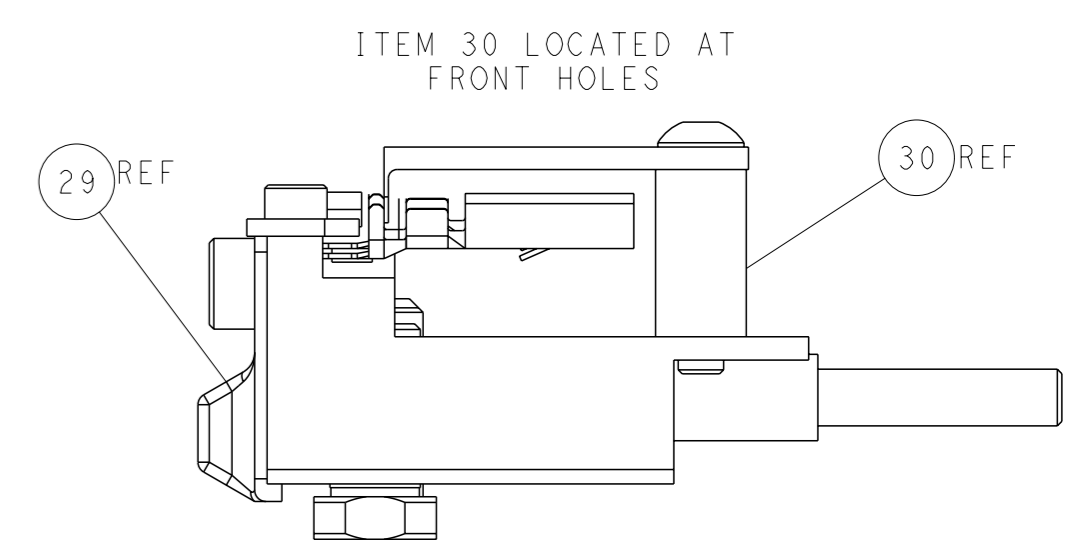

FEED TRACK POSITION GUIDE BY INSULATION BARREL

CAM POSITIONS

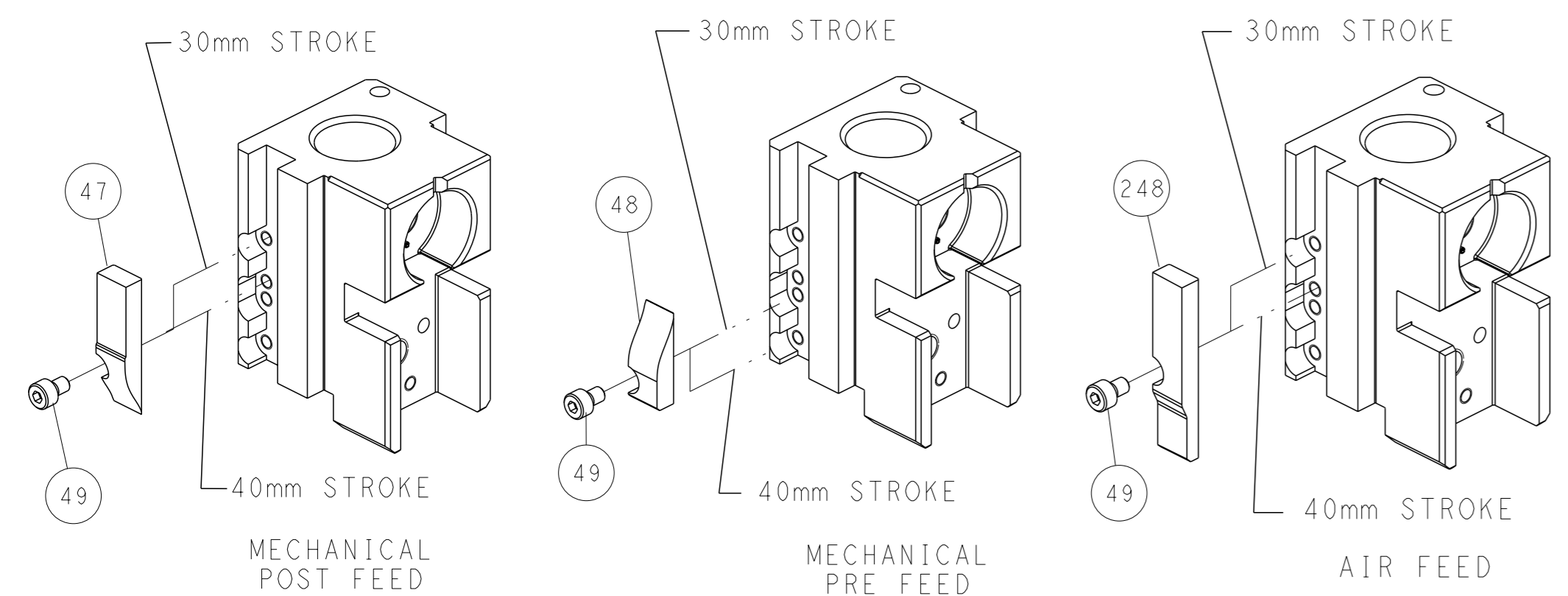

ATLANTIC VERSION
 Shown on sheets 1 of 4 & 2 of 4
 (Pacific version shown on sheets 3 of 4 & 4 of 4)

<small>THIS DRAWING IS A CONTROLLED DOCUMENT FOR TYCO ELECTRONICS CORPORATION. IT IS SUBJECT TO CHANGE AND THE CONTROL AND RESTRICTION DESIGNATION SHOULD BE CONTACTED FOR THE LATEST REVISION.</small>		OWN: R. O. WILSON 09FEB2012 CHK: K. J. STAKEM 20FEB2012 APVD: J. L. ELBIN 21FEB2012	NAME: TE Connectivity Harrisburg, PA 17105-3608
DIMENSIONS: mm TOLERANCES UNLESS OTHERWISE SPECIFIED: 0 PLC ± 1 PLC ± 2 PLC ± 3 PLC ± 4 PLC ± ANGLES FINISH ±	MATERIAL:	PRODUCT SPEC: APPLICATION SPEC: WEIGHT:	SIZE: CAGE CODE DRAWING NO. RESTRICTED TO: A1 00779 ©=2151606 RESTRICTED CUSTOMER SCALE: 1:2 SHEET 2 OF 4 REV B

LOC		DIST		REVISIONS			
A	66	P	LYR	DESCRIPTION	DATE	OWN	APVD
		-		SEE SHEET 1	-	-	-

FEED TYPE MECHANICAL

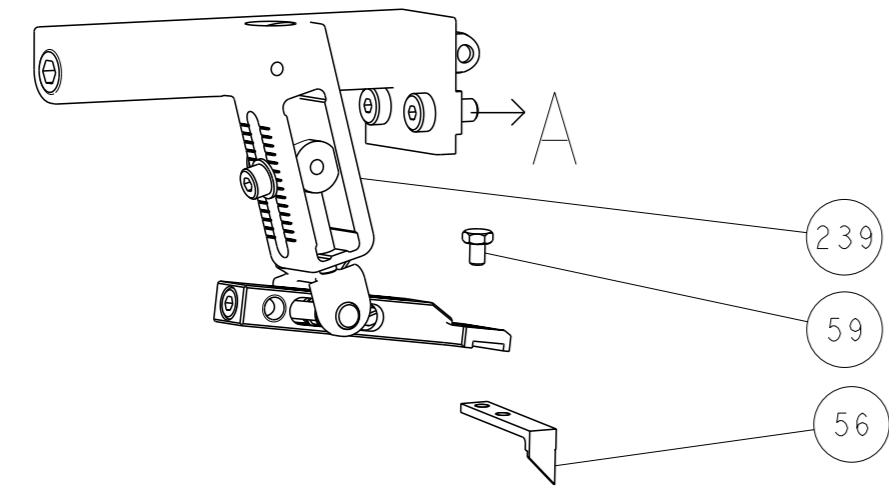

PNEUMATIC

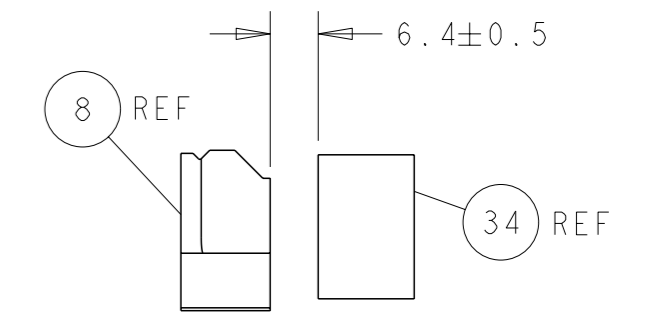
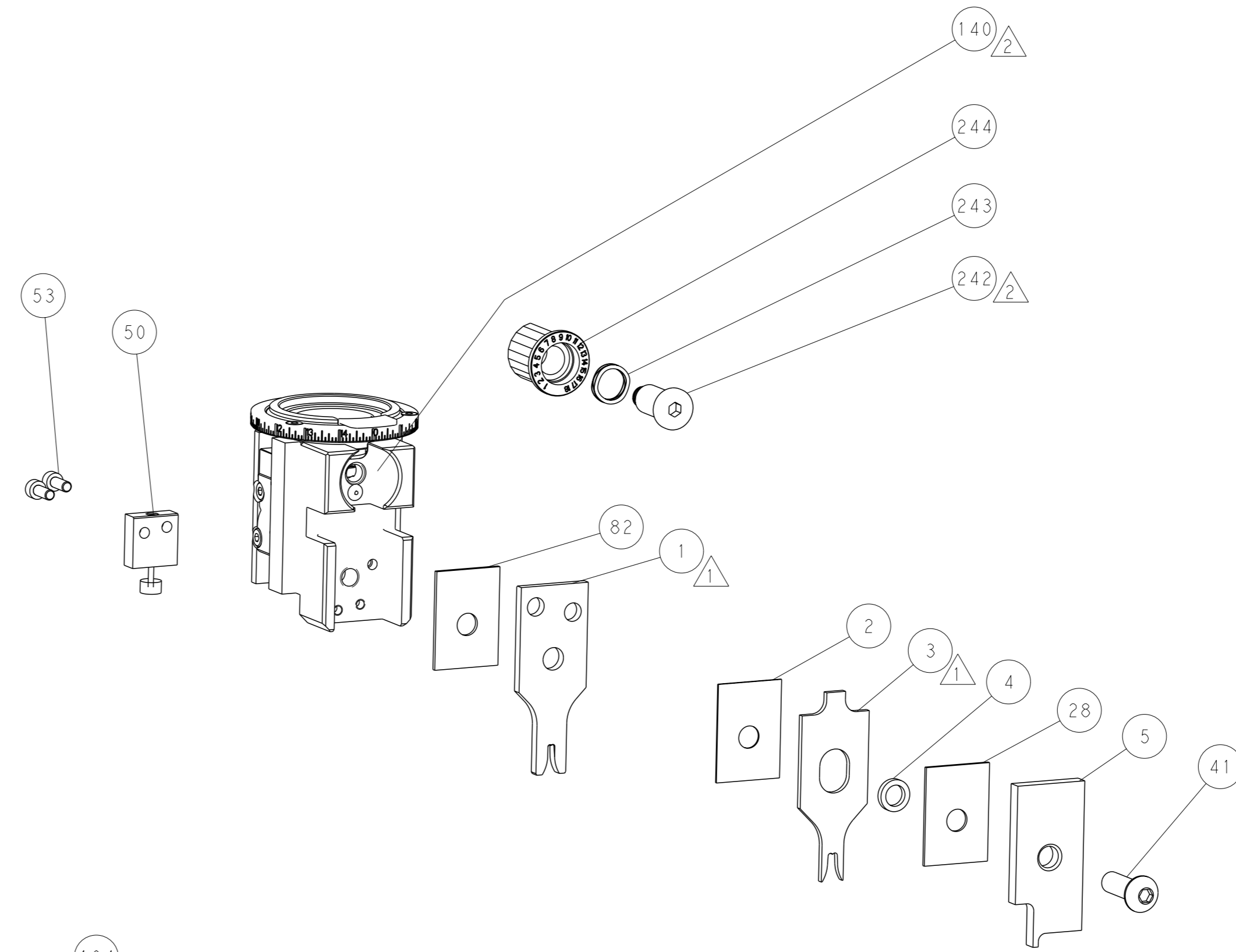
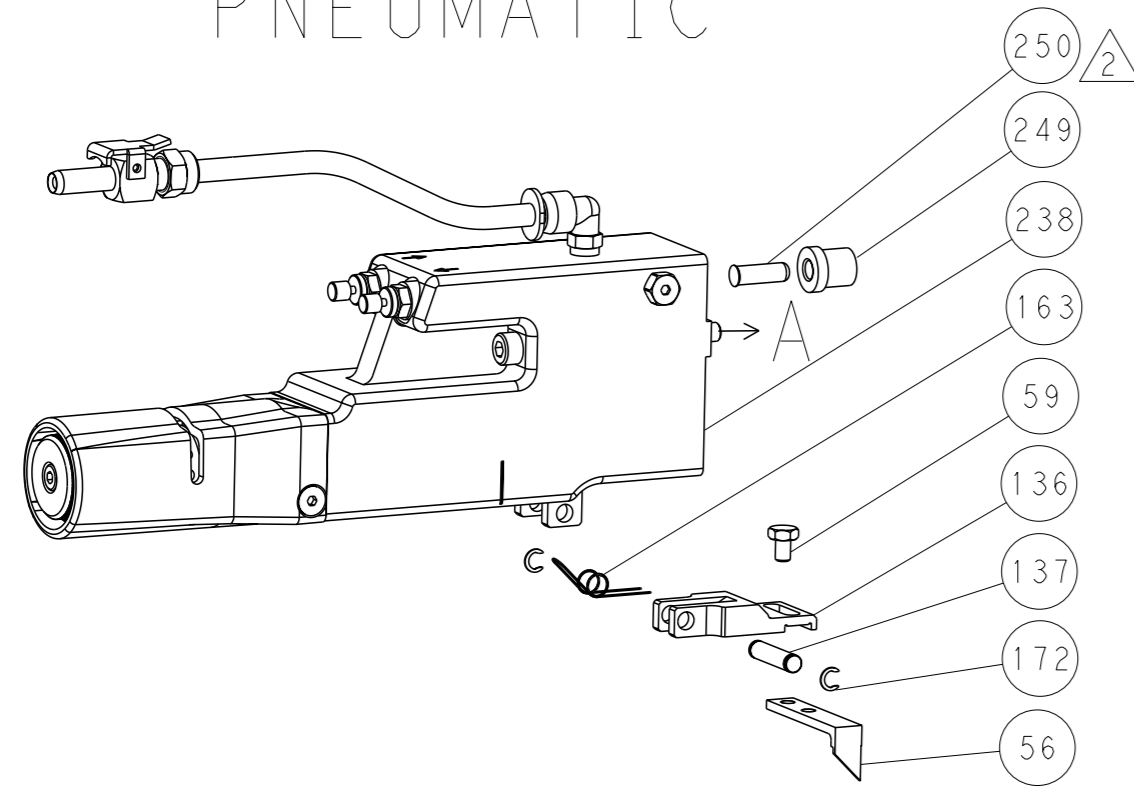

TERMINAL SUPPORT LOCATION

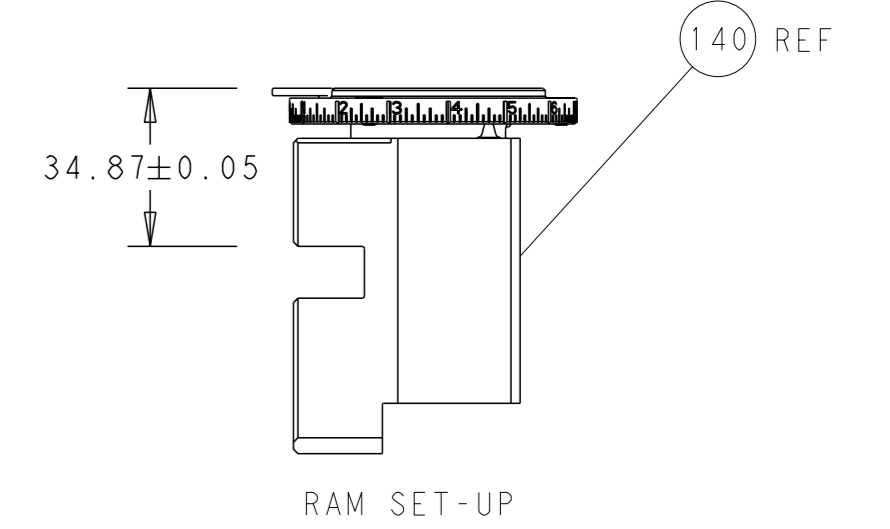
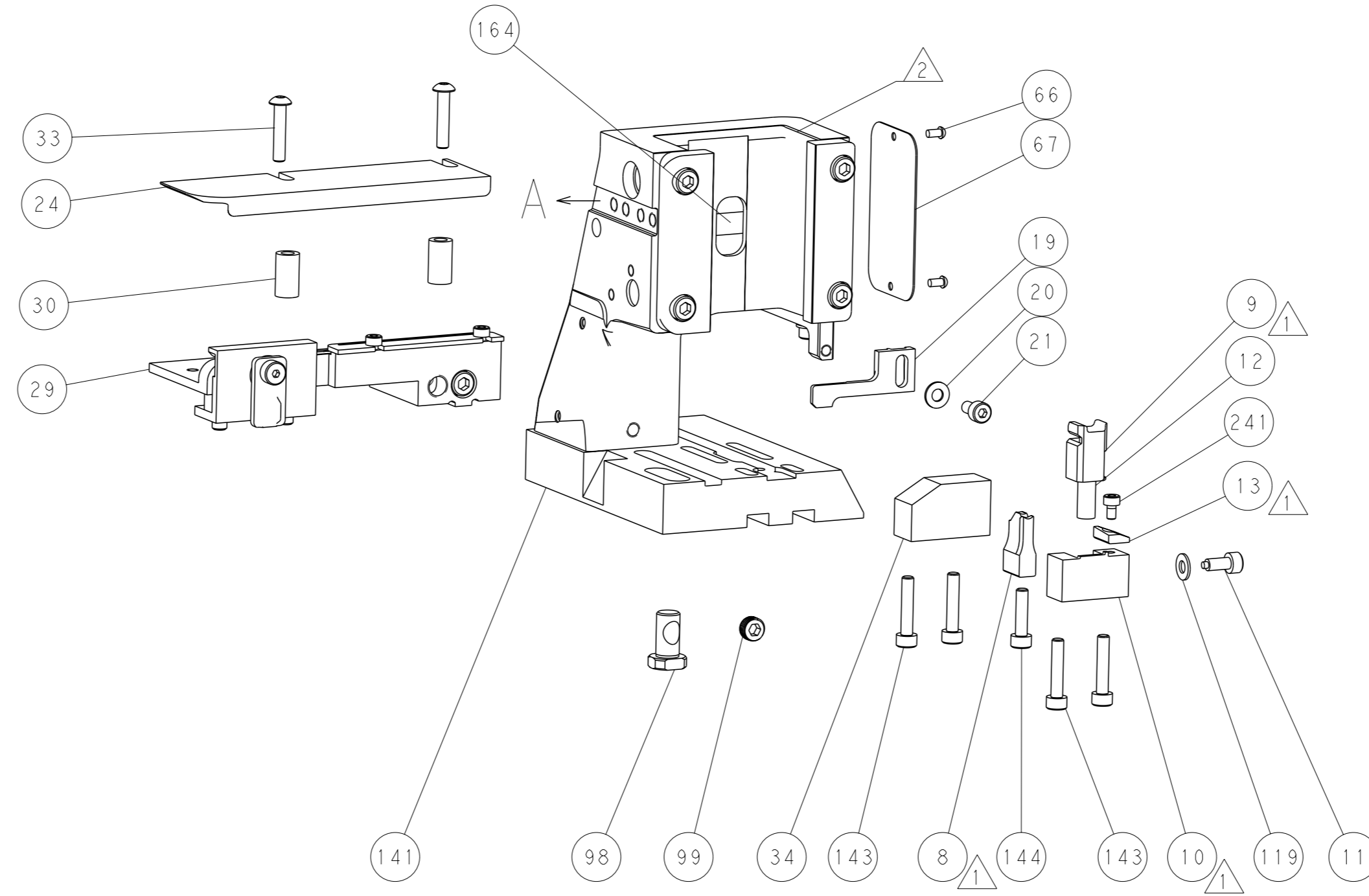

RAM SET-UP

ITEM 30 LOCATED AT FRONT HOLES

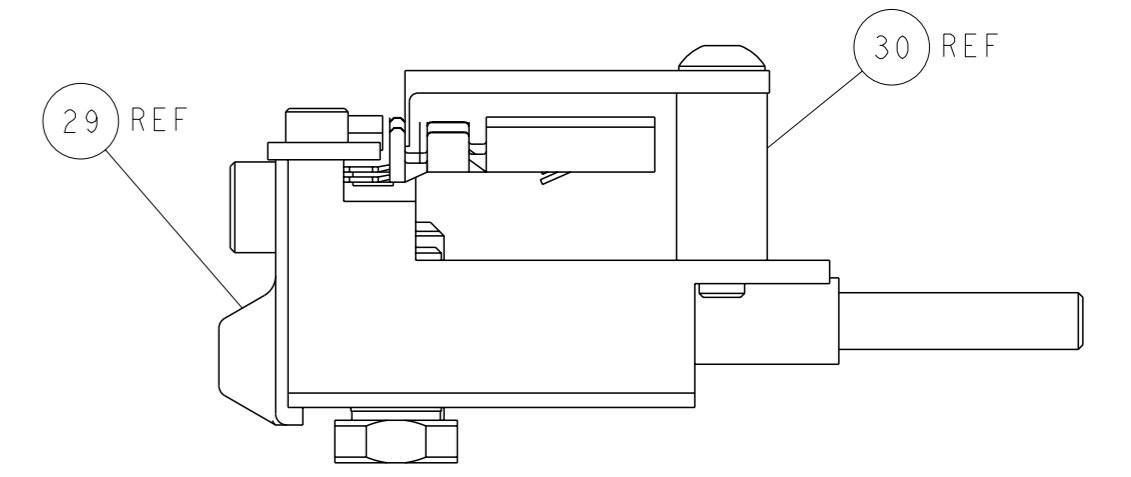

FEED TRACK POSITION GUIDE BY INSULATION BARREL

CAM POSITIONS

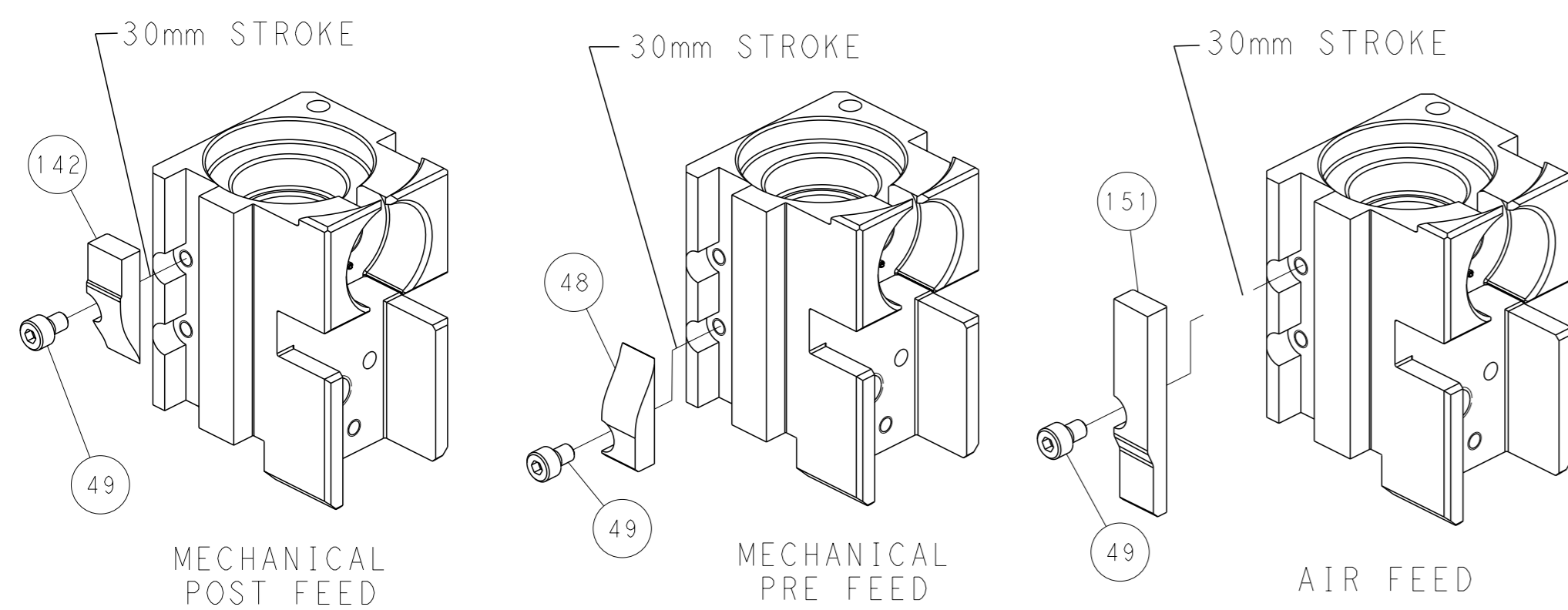

PACIFIC VERSION
 Shown on sheets 3 of 4 & 4 of 4
 (Atlantic version shown on sheets 1 of 4 & 2 of 4)

<small>THIS DRAWING IS A CONTROLLED DOCUMENT FOR TYCO ELECTRONICS CORPORATION. IT IS SUBJECT TO CHANGE AND THE CONTROLLING ENGINEERING ORGANIZATION SHOULD BE CONTACTED FOR THE LATEST REVISION.</small>		OWN: R. O. WILSON 09FEB2012 CHK: K. J. STAKEM 20FEB2012 APVD: J. L. ELBIN 21FEB2012	NAME: TE Connectivity Harrisburg, PA 17105-3608
DIMENSIONS: mm TOLERANCES UNLESS OTHERWISE SPECIFIED: 0 PLC ± 1 PLC ± 2 PLC ± 3 PLC ± 4 PLC ± ANGLES FINISH ±	APPLICATION SPEC: - WEIGHT: - RESTRICTED CUSTOMER: -	SIZE: A1 CAGE CODE: 00779 DRAWING NO: C=2151606	RESTRICTED TO: - SCALE: 1:2 SHEET: 4 of 4 REV: B

Mouser Electronics

Authorized Distributor

Click to View Pricing, Inventory, Delivery & Lifecycle Information:

[TE Connectivity:](#)

[2-2151606-2](#)