

951 06 XX XX XX X X X 50 XXXX

**PLUG WITH POTTING CUP**

TYPE 06 RP  
06 P

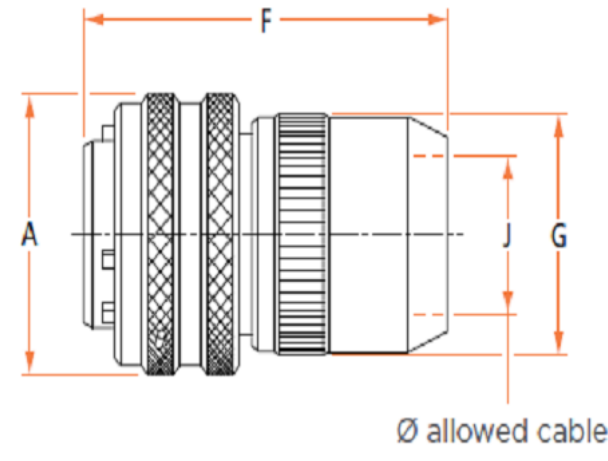

Crimp type Part-number	A max.	F max.	G max.	J mini.	Solder type Part-number
951-06 RP 8-** P/S 50	17.75	39.85	15.40	7.95	951-06 P 8-** P/S 50
951-06 RP 10-** P/S 50	21.05	39.85	18.60	11.05	951-06 P 10-** P/S 50
951-06 RP 12-** P/S 50	24.60	39.85	21.45	14.15	951-06 P 12-** P/S 50
951-06 RP 14-** P/S 50	28.05	45.35	24.70	17.40	951-06 P 14-** P/S 50
951-06 RP 16-** P/S 50	31.10	45.35	27.90	20.55	951-06 P 16-** P/S 50
951-06 RP 18-** P/S 50	34.40	45.35	29.85	23.00	951-06 P 18-** P/S 50
951-06 RP 20-** P/S 50	37.65	46.85	33.15	25.95	951-06 P 20-** P/S 50
951-06 RP 22-** P/S 50	40.90	46.85	36.45	29.10	951-06 P 22-** P/S 50
951-06 RP 24-** P/S 50	44.10	46.85	40.00	32.55	951-06 P 24-** P/S 50

BASIC IDENTIFIER  
TYPE 5 - AS per UTE  
93422 Specifications

SHELL TYPE  
06 Plug

TYPES OF ACCESSORIES  
1

SHELL SIZE  
08-10-12-14-16-18-20-22-24

ARRANGEMENTS

CONTACT TYPE  
P Male Contact  
S Female Contact

INSERT POSITIONING LETTER  
Standard position : no letter  
W-X-Y or Z

TYPE OF CONTACT  
Size 20 Standard, none  
Size 16 Standard, none  
Size 8 Crimp type, consult us  
Solder type standard : issue 8  
Coax : Standard : none  
issue 1 : 1  
issue 3 : 3  
issue F5 : F5

OBLIGATORY SUFFIX

SPECIAL MODIFICATIONS  
311 Clear cadmium plating  
031 Black Anodised plating  
395 Kerosene resisting insert  
A 315 Fitting for thermosink sleeve  
A 231 Special olive drab cadmium  
240 hrs salt spray resistance

**CHARACTERISTIQUES**

- Shell material : Aluminium alloy
- Plating : Standard plating - Olive Drab Cadmium passivated.  
Other plating option - Clear Cadmium,  
Black Anodised for tropical environment
- Type of contact : Crimp or solder type
- Insert material for,  
Crimp type contacts : Fluoro silicone  
Solder type (Nonremovable) contacts : Neoprene
- Temperature range:  
Crimp type -55°C to + 150°C  
Solder type -55°C to + 125°C
- Service Voltage :  
Service rating 1 : 500 VRMS 50 Hz  
Service rating 2 : 750 VRMS 50 Hz

**PLUG WITH NUT**

TYPE 06 R  
06 E

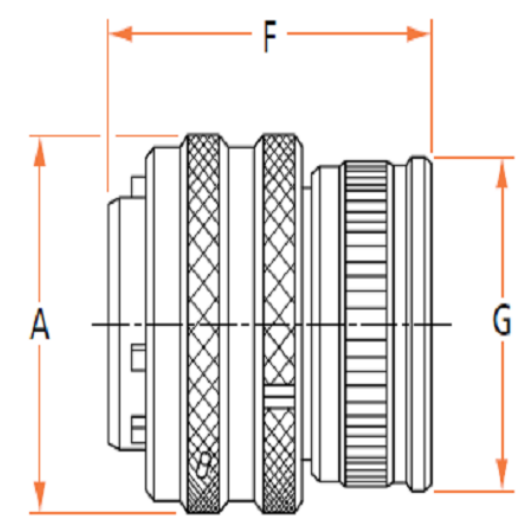

Crimp type Part-number	A max.	F max.	G max.	Solder type Part-number
951-06 R 8-** P/S 50	17.75	31.20	15.50	951-06 E 8-** P/S 50
951-06 R 10-** P/S 50	21.05	31.20	18.70	951-06 E 10-** P/S 50
951-06 R 12-** P/S 50	24.60	31.20	21.80	951-06 E 12-** P/S 50
951-06 R 14-** P/S 50	28.05	31.20	25.00	951-06 E 14-** P/S 50
951-06 R 16-** P/S 50	31.10	31.20	28.20	951-06 E 16-** P/S 50
951-06 R 18-** P/S 50	34.40	31.20	30.25	951-06 E 18-** P/S 50
951-06 R 20-** P/S 50	37.65	32.75	33.55	951-06 E 20-** P/S 50
951-06 R 22-** P/S 50	40.90	32.75	36.85	951-06 E 22-** P/S 50
951-06 R 24-** P/S 50	44.10	32.75	40.50	951-06 E 24-** P/S 50

Accessories	Crimping contacts Shell						Soldering contacts* Shell					
	00	01	02	06	07	08	00	01	02	06	07	08
Nut	R	R	-	R	R	-	E	E	-	E	E	-
Adaptor	RA	RA	-	RA	-	-	A	A	-	A	-	-
Straight cable clamp	RC	RC	-	RC	RC	-	EC	EC	-	EC	EC	-
Water-tight	RJ	RJ	-	RJ	RJ	-	J	J	-	J	J	-
Potting cup	RP	RP	-	RP	RP	-	P	P	-	P	P	-
Nut	-	SK	-	SK	-	-	-	EK	-	EK	-	-
Without nut	-	-	R	-	RA	-	-	-	E	-	A	-
Elbowed cable clamp	-	-	-	-	-	RC	-	-	-	-	-	EC
Closed elbowed cable clamp	-	-	-	-	-	SC	-	-	-	-	-	C
Closed water-tight end bell	-	-	-	-	-	SJ	-	-	-	-	-	EJ
Water-tight collecting end bell	-	-	-	-	-	SK	-	-	-	-	-	EK
Elbowed cable clamp and water-tight	-	-	-	-	-	SL	-	-	-	-	-	EL
Grounding adaptor	RT	RT	-	RT	RT	-	-	-	-	-	-	-

\*Consult us for the soldering contact version.

DWN <b>LAKSHMI SUDHA R</b>	MATERIAL -	HEAT TREAT -
CHK <b>RAKESH S</b>		
APVD <b>VINCENT P</b>		
NAME <b>951 Series_Plug</b>		
SCALE 2:1	SIZE A2	DRAWING NO 951-06_++
SHEET 1 of 1	REV A	

DIMENSIONS: MM	TOLERANCES UNLESS OTHERWISE SPECIFIED:
0 PLC	±
1 PLC	±0.05
2 PLC	±0.05
3 PLC	±0.02
4 PLC	±
ANGLES ±	
SURFACE TEXTURE	√

# Mouser Electronics

Authorized Distributor

Click to View Pricing, Inventory, Delivery & Lifecycle Information:

[TE Connectivity:](#)

[ZPF00000000006697](#)