

| LDC |     | JUST          |      | REVISIONS |      |      |    |
|-----|-----|---------------|------|-----------|------|------|----|
| P   | LTR | DESCRIPTION   | DATE | DM        | AP/3 | DATE | DM |
| A   |     | FIRST VERSION |      |           |      |      |    |

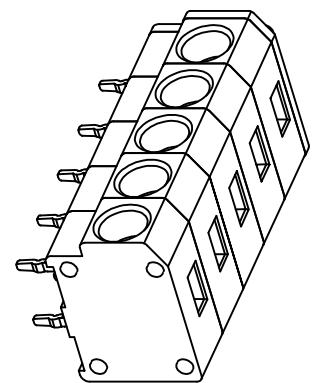
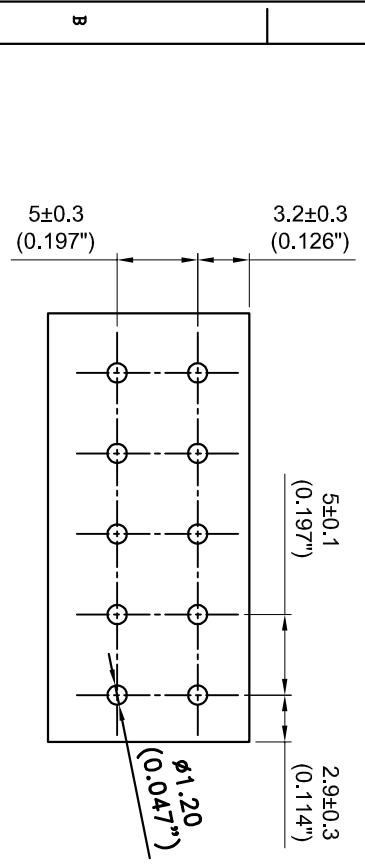
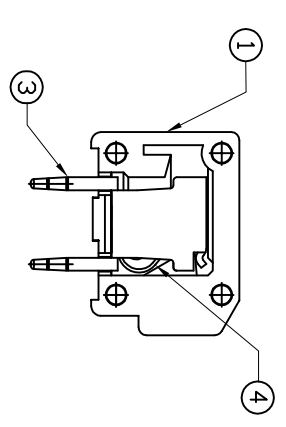
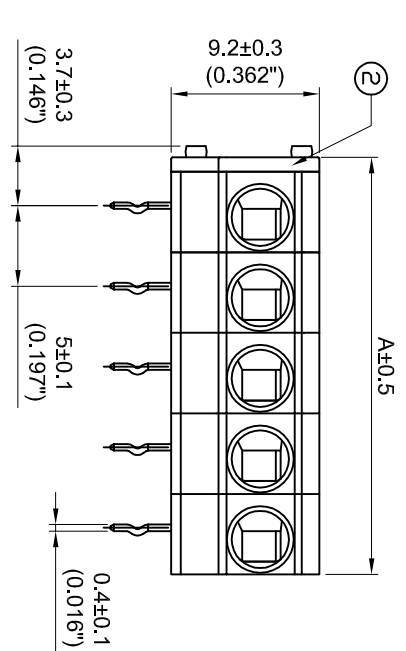
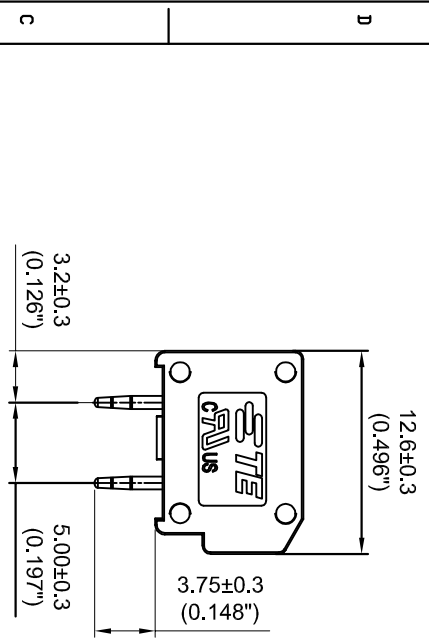

| ④     | WIRE PROTECTOR |           |
|-------|----------------|-----------|
| ③     | CONTACT        |           |
| ②     | COVER          |           |
| ①     | HOUSING        |           |
| 40.90 | 8 POSN         | 2834097-7 |
| 35.90 | 7 POSN         | 2834097-6 |
| 30.90 | 6 POSN         | 2834097-5 |
| 25.90 | 5 POSN         | 2834097-4 |
| 20.90 | 4 POSN         | 2834097-3 |
| 15.90 | 3 POSN         | 2834097-2 |
| 10.90 | 2 POSN         | 2834097-1 |

- NOTES :
- △ MATERIALS AND FINISH:
    - HOUSING: PA66
    - CONTACTS: COPPER, FINISH: TIN OVER NICKEL UNDERPLATE
  - 2. MUST COMPLY WITH DIRECTIVE 2002/95/EC (ROHS)
  - 3. WIRE TYPES AND SIZES ACCEPTED
    - WIRE RANGE: 14AWG~20AWG.
    - STRIP LENGTH: 9.0mm~10.0mm
  - 4. PACKAGED IN TRAY.
  - 5. CURRENT RATING: 10Amp AC300V.
  - 6. OPERATION TEMPERATURE: -40°C TO +105°C
  - 7. THIS PART NO. IS THE SAME STRUCTURE AS THE SERIES: 2834097
- THE DATASHEET AND MORE DETAILS PLEASE FOLLOW THE SERIES: 2834097

THIS DRAWING IS A CONTROLLED DOCUMENT.

|          |           |           |     |
|----------|-----------|-----------|-----|
| DESIGNER | CHKD      | DATE      | REV |
| FW       | 02DEC2015 | 02DEC2015 | 1   |

REVISIONS: 108-137147

DATE: 11-4-137147

SCALE: 1:1

REV: A

# Mouser Electronics

Authorized Distributor

Click to View Pricing, Inventory, Delivery & Lifecycle Information:

[TE Connectivity:](#)

[2834097-3](#)