

REVISIONS			
REV	DATE	BY	APP
1	17JUN2019	KJK	PS

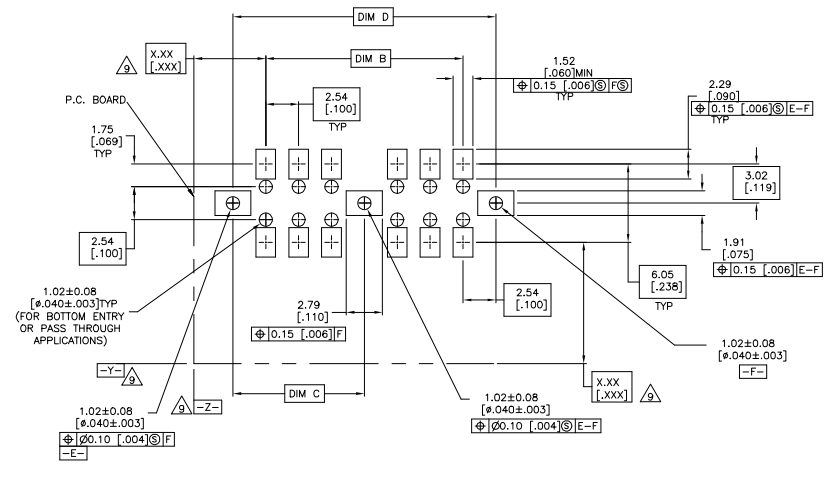
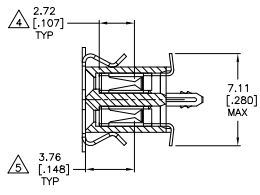
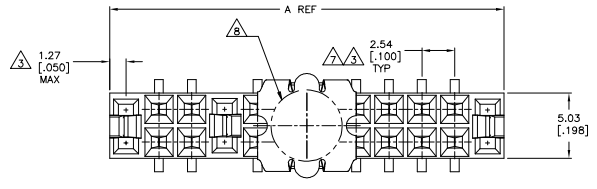
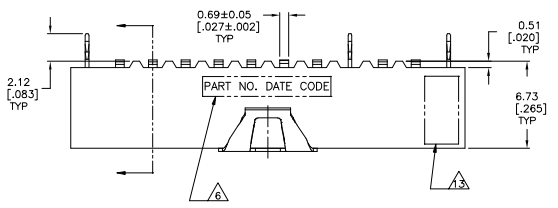

RECOMMENDED PC BOARD PAD PATTERN
0.020[.008] THICK STENCIL

FINISH	EIA TAPE WIDTH	D	C	B	A	NO OF POSN	PART NUMBER
▲▲	N/A	106.68 [4.200]	53.34 [2.100]	101.6 [4.000]	109.22 [4.300]	80	4-147747-0
▲▲	120mm	104.14 [4.100]	50.80 [2.000]	99.06 [3.900]	106.68 [4.200]	78	3-147747-9
▲▲		101.60 [4.000]	50.80 [2.000]	96.52 [3.800]	104.14 [4.100]	76	3-147747-8
▲▲		99.06 [3.900]	48.26 [1.900]	93.98 [3.700]	101.6 [4.000]	74	3-147747-7
▲▲		96.52 [3.800]	48.26 [1.900]	91.44 [3.600]	99.06 [3.900]	72	3-147747-6
▲▲		93.98 [3.700]	45.72 [1.800]	88.9 [3.500]	96.52 [3.800]	70	3-147747-5
▲▲		88.90 [3.500]		83.82 [3.300]	91.44 [3.600]	68	3-147747-4
▲▲		86.36 [3.400]		81.28 [3.200]	88.9 [3.500]	66	3-147747-3
▲▲		83.82 [3.300]		78.74 [3.100]	86.36 [3.400]	64	3-147747-2
▲▲		81.28 [3.200]		76.2 [3.000]	83.82 [3.300]	62	3-147747-1
▲▲		78.74 [3.100]		71.12 [2.900]	81.28 [3.200]	60	3-147747-0
▲▲		76.20 [3.000]		71.12 [2.800]	78.74 [3.100]	58	2-147747-9
▲▲		71.12 [2.900]		68.58 [2.700]	76.2 [3.000]	56	2-147747-8
▲▲	88mm	71.12 [2.800]		66.04 [2.600]	71.12 [2.900]	54	2-147747-7
▲▲		68.58 [2.700]		63.5 [2.500]	71.12 [2.800]	52	2-147747-6
▲▲		66.04 [2.600]		60.96 [2.400]	68.58 [2.700]	50	2-147747-5
▲▲		63.50 [2.500]		58.42 [2.300]	66.04 [2.600]	48	2-147747-4
▲▲		60.96 [2.400]		55.88 [2.200]	63.5 [2.500]	46	2-147747-3
▲▲		58.42 [2.300]		53.34 [2.100]	60.96 [2.400]	44	2-147747-2
▲▲		55.88 [2.200]		50.8 [2.000]	58.42 [2.300]	42	2-147747-1
▲▲		53.34 [2.100]		48.26 [1.900]	55.88 [2.200]	40	2-147747-0
▲▲	72mm	50.80 [2.000]		45.72 [1.800]	53.34 [2.100]	38	1-147747-9
▲▲		48.26 [1.900]		43.18 [1.700]	50.8 [2.000]	36	1-147747-8
▲▲		45.72 [1.800]		40.64 [1.600]	48.26 [1.900]	34	1-147747-7
▲▲		43.18 [1.700]		38.1 [1.500]	45.72 [1.800]	32	1-147747-6
▲▲		40.64 [1.600]		35.56 [1.400]	43.18 [1.700]	30	1-147747-5
▲▲		38.10 [1.500]		33.02 [1.300]	40.64 [1.600]	28	1-147747-4
▲▲		35.56 [1.400]		30.48 [1.200]	38.1 [1.500]	26	1-147747-3
▲▲		33.02 [1.300]		27.94 [1.100]	35.56 [1.400]	24	1-147747-2
▲▲		30.48 [1.200]		25.4 [1.000]	33.02 [1.300]	22	1-147747-1
▲▲		27.94 [1.100]		22.86 [.900]	30.48 [1.200]	20	1-147747-0
▲▲	44mm	25.40 [1.000]		20.32 [.800]	27.94 [1.100]	18	147747-9
▲▲		22.86 [.900]		17.78 [.700]	25.4 [1.000]	16	147747-8
▲▲		20.32 [.800]		15.24 [.600]	22.86 [.900]	14	147747-7
▲▲		17.78 [.700]		12.7 [.500]	20.32 [.800]	12	147747-6
▲▲		15.24 [.600]		10.16 [.400]	17.78 [.700]	10	147747-5
▲▲		12.70 [.500]		7.62 [.300]	15.24 [.600]	8	147747-4
▲▲		10.16 [.400]		5.08 [.200]	12.7 [.500]	6	147747-3
▲▲	24mm	7.62 [.300]		2.54 [.100]	10.16 [.400]	4	147747-2
▲▲		5.08 [.200]			7.62 [.300]	2	147747-1

THIS DRAWING IS A CONTROLLED DOCUMENT

DESIGNED BY: J. J. OLSON
 DRAWING NO: 108-25022
 DATE: 11/14/08

REVISED BY: J. J. OLSON
 REVISED DATE: 11/14/08

DESCRIPTION: AMPAD00, RCPT ASSY, MOD IV, DR, VERTICAL, DUAL ENTRY, 100X.100 C/L, SMT.

SCALE: 6:1

CUSTOMER DRAWING

DATE: 11/14/08

REV: 2

APP: PS

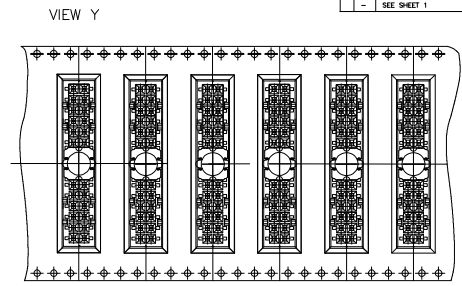
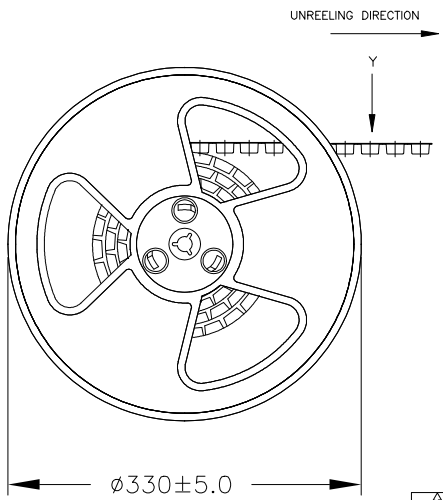

- △ HOUSING: GLASS FILLED, FLAME RETARDANT POLYESTER, BLACK CONTACTS: PHOSPHOR BRONZE, VACUUM COVER: STAINLESS STEEL
- △ CONTACTS: DUPLEX PLATED-0.76μm[.000030] GOLD IN CONTACT AREA, 3.81-7.62μm [.000150-.000300] BRIGHT TIN-LEAD ON LEADS, ALL OVER 1.27μm [.000050] MIN NICKEL.
- △ DIMENSION APPLIES TO HOUSING CAVITY CENTERLINES ONLY.
- △ POINT OF MEASUREMENT FOR PLATING THICKNESS.
- △ POINT OF CONTACT DIMENSION.
- △ MARK PART NUMBER AND DATE CODE IN APPROXIMATE LOCATION SHOWN, EITHER SIDE.
- △ TOLERANCE IS NON-CUMULATIVE.
- △ 5.5 [.217] MIN TARGET AREA FOR VACUUM PICK-UP COVERS TO BE REMOVED AFTER SOLDERING.
- △ DATUMS AND BASIC DIMENSIONS ESTABLISHED BY CUSTOMER.
- △ NO CENTER HOLD DOWNS
- 11 PACKAGED IN TAPES AND REEL PER EIA 481 SPECIFICATIONS.
- △ FOR 2 POS. DATE CODE IS STAMPED OPPOSITE SIDE OF TE LOGO.
- △ TE TRADEMARK AND CSA LOGO ARE MOLDED INTO HOUSING.
- △ NO PART NUMBER MARKING REQUIRED ON THIS PART.
- △ CONTACTS: DUPLEX PLATED-0.76μm[.000030] GOLD IN CONTACT AREA, 3.81-7.62μm [.000150-.000300] MATTE TIN ON LEADS, ALL OVER 1.27μm [.000050] MIN NICKEL.
- △ ROHS 2002/95/EC COMPLIANT

△		106.68	[4.200]	53.34	[2.100]	101.6	[4.000]	109.22	[4.300]	80	△	9-147747-0
△		104.14	[4.100]	50.8	[2.000]	99.06	[3.900]	106.68	[4.200]	78	△	8-147747-9
△		101.6	[4.000]	50.8	[2.000]	96.52	[3.800]	104.14	[4.100]	76	△	8-147747-8
△		99.06	[3.900]	48.26	[1.900]	93.98	[3.700]	101.6	[4.000]	74	△	8-147747-7
△		96.52	[3.800]	48.26	[1.900]	91.44	[3.600]	99.06	[3.900]	72	△	8-147747-6
△		93.98	[3.700]	45.72	[1.800]	88.9	[3.500]	96.52	[3.800]	70	△	8-147747-5
△	120mm	88.9	[3.500]			83.82	[3.300]	91.44	[3.600]	68	△	8-147747-4
△		86.36	[3.400]			81.28	[3.200]	88.9	[3.500]	66	△	8-147747-3
△		83.82	[3.300]			78.74	[3.100]	86.36	[3.400]	64	△	8-147747-2
△		81.28	[3.200]			76.2	[3.000]	83.82	[3.300]	62	△	8-147747-1
△		78.74	[3.100]			71.12	[2.900]	81.28	[3.200]	60	△	8-147747-0
△		76.2	[3.000]			71.12	[2.800]	78.74	[3.100]	58	△	7-147747-9
△		71.12	[2.900]			68.58	[2.700]	76.2	[3.000]	56	△	7-147747-8
△		71.12	[2.800]			66.04	[2.600]	71.12	[2.900]	54	△	7-147747-7
△		68.58	[2.700]			63.5	[2.500]	71.12	[2.800]	52	△	7-147747-6
△	88mm	66.04	[2.600]			60.96	[2.400]	68.58	[2.700]	50	△	7-147747-5
△		63.5	[2.500]			58.42	[2.300]	66.04	[2.600]	48	△	7-147747-4
△		60.96	[2.400]			55.88	[2.200]	63.5	[2.500]	46	△	7-147747-3
△		58.42	[2.300]			53.34	[2.100]	60.96	[2.400]	44	△	7-147747-2
△		55.88	[2.200]			50.8	[2.000]	58.42	[2.300]	42	△	7-147747-1
△		53.34	[2.100]			48.26	[1.900]	55.88	[2.200]	40	△	7-147747-0
△		50.8	[2.000]			45.72	[1.800]	53.34	[2.100]	38	△	6-147747-9
△		48.26	[1.900]			43.18	[1.700]	50.8	[2.000]	36	△	6-147747-8
△	72mm	45.72	[1.800]			40.64	[1.600]	48.26	[1.900]	34	△	6-147747-7
△		43.18	[1.700]			38.1	[1.500]	45.72	[1.800]	32	△	6-147747-6
△		40.64	[1.600]			35.56	[1.400]	43.18	[1.700]	30	△	6-147747-5
△		38.1	[1.500]			33.02	[1.300]	40.64	[1.600]	28	△	6-147747-4
△		35.56	[1.400]			30.48	[1.200]	38.1	[1.500]	26	△	6-147747-3
△		33.02	[1.300]			27.94	[1.100]	35.56	[1.400]	24	△	6-147747-2
△		30.48	[1.200]			25.4	[1.000]	33.02	[1.300]	22	△	6-147747-1
△		27.94	[1.100]			22.86	[.900]	30.48	[1.200]	20	△	6-147747-0
△		25.4	[1.000]			20.32	[.800]	27.94	[1.100]	18	△	5-147747-9
△		22.86	[.900]			17.78	[.700]	25.4	[1.000]	16	△	5-147747-8
△		20.32	[.800]			15.24	[.600]	22.86	[.900]	14	△	5-147747-7
△		17.78	[.700]			12.7	[.500]	20.32	[.800]	12	△	5-147747-6
△		15.24	[.600]			10.16	[.400]	17.78	[.700]	10	△	5-147747-5
△		12.7	[.500]			7.62	[.300]	15.24	[.600]	8	△	5-147747-4
△		10.16	[.400]			5.08	[.200]	12.7	[.500]	6	△	5-147747-3
△		7.62	[.300]			2.54	[.100]	10.16	[.400]	4	△	5-147747-2
△	24mm	5.08	[.200]					7.62	[.300]	2	△	5-147747-1
	FINISH											
	EIA TAPE WIDTH		D		C		B		A		NO OF POSN	PART NUMBER

THIS DRAWING IS A CONTROLLED DOCUMENT

DESIGNED BY: J. L. OLSON
 DRAWN BY: J. L. OLSON
 CHECKED BY: J. L. OLSON
 APPROVED BY: J. L. OLSON

DATE: 108-25022
 SIZE: 114-25018

REVISIONS: 1
 DATE: 10/27/98
 BY: J. L. OLSON
 APP'D: J. L. OLSON

CUSTOMER DRAWING

TE Connectivity Ltd.
 RCPT ASSY, MOD IV, DOUBLE ROW,
 VERTICAL, DUAL ENTRY, 100X100 C/L,
 SURFACE MOUNT, AMPMODII

SCALE: 1:1
 SHEET: 2 OF 2

Mouser Electronics

Authorized Distributor

Click to View Pricing, Inventory, Delivery & Lifecycle Information:

[TE Connectivity:](#)

[6-147747-2](#)