

MATED WITH / Passend zu:		PROJEKT NR. / A97-52046	LOC. / AI	DIST. / -	REVISIONS			
REV.	DATE	DESCRIPTION	DATE	OWN	APVD			
E	29SEP2018	CHANGE OF BASE MATERIAL			SCHO			
E1	29NOV2018	PART REV. IN CHART ON SHEET 2 OF 2 REVISED			SCHO			
E2	12FEB2019	SEE PCN E-19-002255			SCHO			
F	21JAN2020	SEE PCN E-19-011087			SCHO			

- NOTES**  
Bemerkungen
- MATING CONNECTOR FOR AMP MCP 2.8 HOUSING  
SEE DRAWINGS 1355072 (TAB HOUSINGS),  
1964562 (TAB HOUSINGS),  
966140 (TAB HEADER),  
114-18085-025 (INTERFACE-DRAWING)  
Gegenstecker fuer AMP MCP 2.8 Gehaeuse  
siehe Zeichnungen 1355072 (Flachstecker-Gehaeuse),  
1964562 (Flachstecker-Gehaeuse),  
966140 (Messleiste),  
114-18085-025 (Ausfuhrungsvorschrift)
  - CAVITIES MATING WITH AMP MCP 2.8 CONTACTS  
(WITHOUT SWS. MAX. WIRE SIZE: 2.5mm<sup>2</sup> FLR) -  
SEE PRODUCT GROUP DRAWING: 1355036  
Kontaktkammern passend fuer AMP MCP 2.8 Kontakte  
(ohne EDS. max. Leitungsquerschnitt: 2.5mm<sup>2</sup> FLR)  
- siehe Produktgruppenzeichnung : 1355036
  - DESIGN DEPENDS ON NUMBER OF WAYS  
Aussehen je nach Polzahl unterschiedlich
  - WARPAGE TO ... PERMITTED  
Verzug bis ... zulaessig
  - MOULD CAVITY-MARKING = X  
SERIAL MOULD-NUMBER = n. (if n>1 only)  
Nestmarkierung = X  
Serienwerkzeug-Nr. = n (nur wenn n>1)
  - MATERIAL-MARKING ACC. TO VDA 260  
Werkstoffkennzeichnung nach
  - CAVITY-MARKING  
Kammerbezeichnung
  - THE REVISION STATUS OF THE MOULD  
Aenderungszustand des Werkzeuges
  - TE PARTNUMBER  
TE Bestell-Nr. Teil
  - WARPAGE TO 11.3 PERMITTED  
Verzug bis 11.3 zulaessig
  - PRODUCTION-DATE  
Produktionsdatum
  - PACKAGING: BULK PACKAGING IN CORRUGATED BOX -  
INDICATED BY PRE-DASH-NO.s 8-, 7-, 6-, 5-;  
THESE PRE-DASH-NO.s ARE ON PART NOW:  
Verpackung: Schuetttgut in Versandkarton -  
gekennzeichnet durch Vorstrichzahlen 8-, 7-, 6-, 5-;  
diese Vorstrichzahlen sind jetzt auch am Teil!
  - MALFUNCTION CAUSED BY LACQUER IS NOT  
COVERED BY TE WARRANTY  
Funktionbeeintraechtigung durch Lackieren liegt  
nicht im Einfluss und Gewaehrleistungsumfang von TE
  - COMPANY LOGO  
Firmenzeichen

	6	30	36.2	38	39.9	41	34.2	11.6g	21
	5	25	31.2	33	34.9	36	29.2	10.3g	18
	4	20	26.2	28	29.9	31	15.5	9.0g	15
	3	15	21.2	23	24.9	26	10.5	7.7g	12
	2	10	16.2	18	19.9	21	5.5	6.3g	9
	1	5	11.2	13	14.9	16	4.5	4.9g	6
M1:1	n	b	c <sup>+0.1</sup> <sub>-0.3</sub>	d <sup>+0.4</sup> <sub>-0.3</sub>	e <sup>+0.2</sup> <sub>-0.5</sub>	f	g±0.25	WEIGHT Gewicht	NUMBER OF WAYS Polzahl

**PRE-LOCKED AND FINAL POSITION**  
Vorrast- und Endraststellung  
SLIDING DISTANCE: 1mm  
Verschiebeweg: 1mm

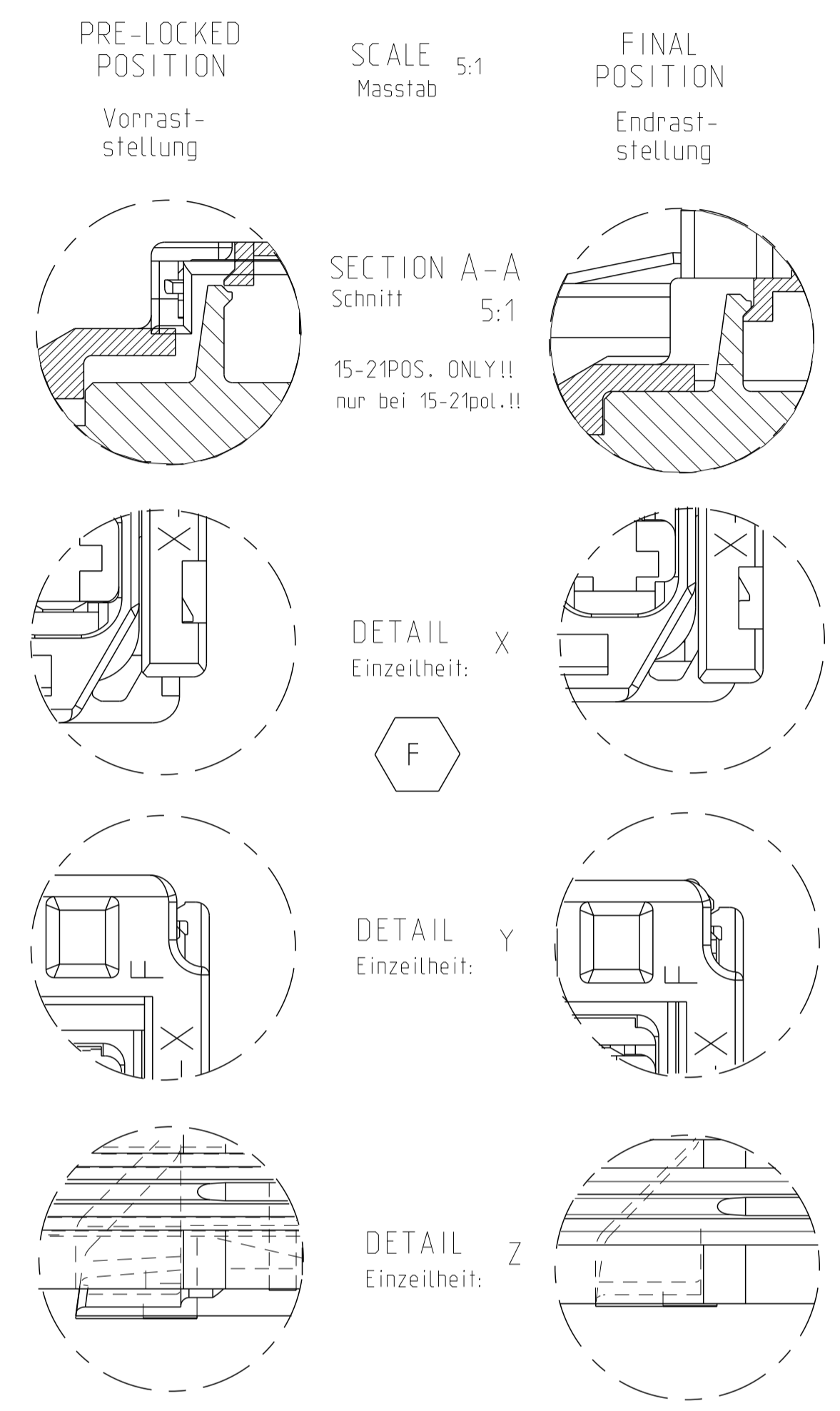

8-968974-1 AS SHOWN IN PRE-LOCKED POSITION  
wie gezeichnet in Vorraststellung

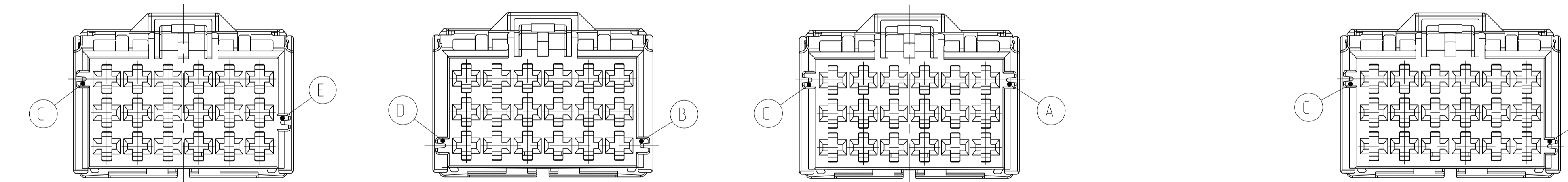
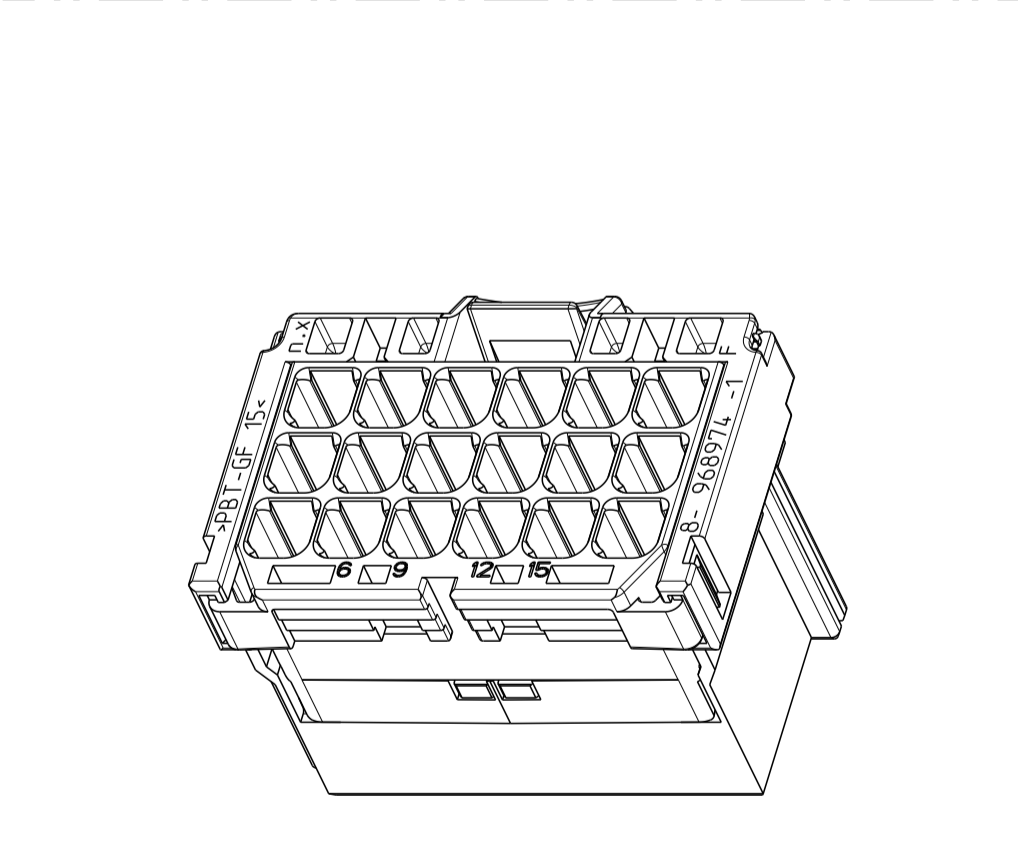
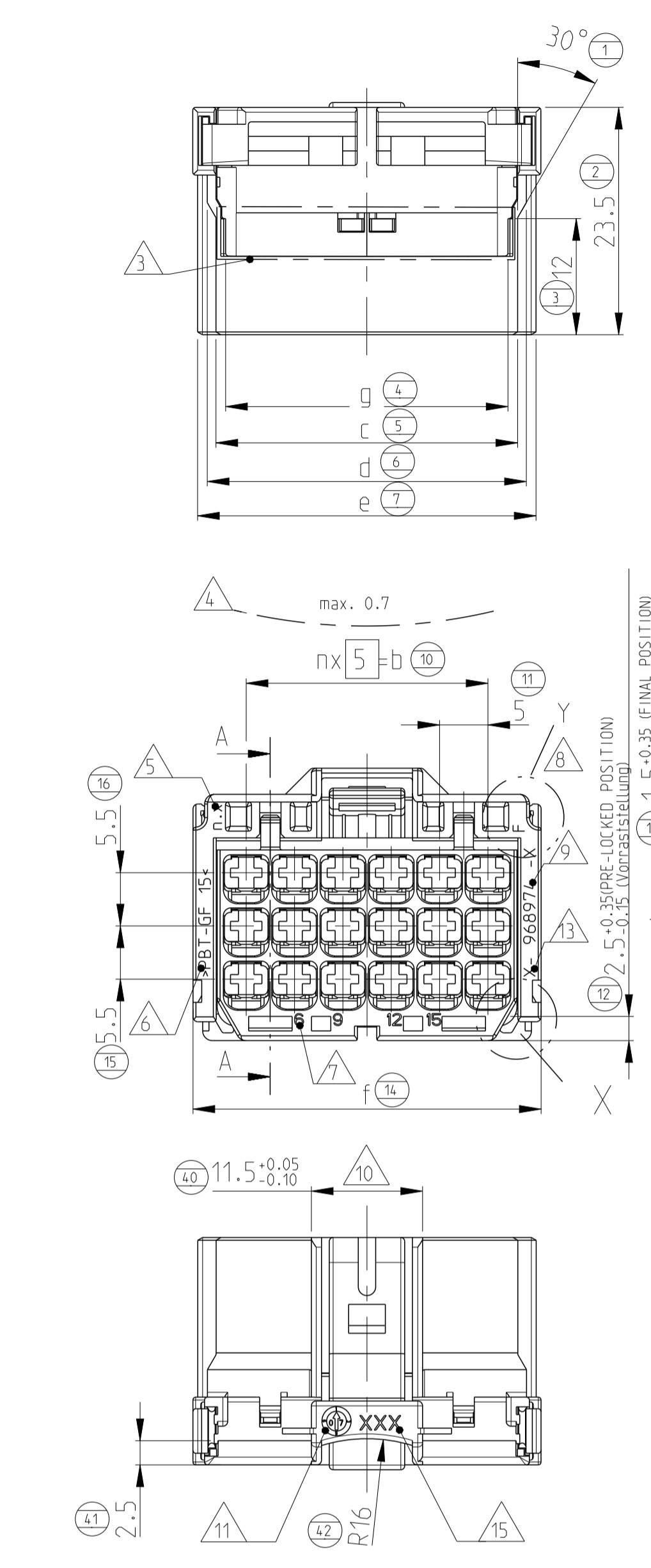

CODING / Kodierung D RIB / Rippe: C-E				CODING / Kodierung C RIB / Rippe: B-D				CODING / Kodierung B RIB / Rippe: A-C				CODING / Kodierung A RIB / Rippe: B-C				MECHAN. CODING			
CUSTOMER PART NO. Kunden-Teile-Nr.	TE ORDER-NO. TE Bestell-Nr.	REV	COLOUR Farbe	CUSTOMER PART NO. Kunden-Teile-Nr.	TE ORDER-NO. TE Bestell-Nr.	REV	COLOUR Farbe	CUSTOMER PART NO. Kunden-Teile-Nr.	TE ORDER-NO. TE Bestell-Nr.	REV	COLOUR Farbe	CUSTOMER PART NO. Kunden-Teile-Nr.	TE ORDER-NO. TE Bestell-Nr.	REV	COLOUR Farbe	POS.	DESCRIPTION Benennung Einzelteil	MATERIAL Werkstoff	
	5-968975-1	F	CLARET VIOLET Bordeauxviolett		6-968975-1	F	LIGHT BLUE Lichtblau		7-968975-1	F	NATURE natur		8-968975-2	F	GREY grau	1	BROWN braun	21	POS. polig
	5-968974-1	F			6-968974-1	F			7-968974-1	F			-	-	-	1	GREY grau	18	POS. polig
	5-968973-1	F			6-968973-1	F			7-968973-1	F			8-968973-2	F	GREY grau	1	VIOLET violett	15	POS. polig
	5-968972-1	F			6-968972-1	F			7-968972-1	F			8-968972-2	F	GREY grau	1	GREEN gruen	12	POS. polig
	5-968971-1	F			6-968971-1	F			7-968971-1	F			8-968971-2	F	GREY grau	1	YELLOW gelb	9	POS. polig
	5-968970-1	F			6-968970-1	F			7-968970-1	F			8-968970-2	F	GREY grau	1	GENTIAN BLUE Enzianblau	6	POS. polig

MATED WITH / PASSEND ZU:		PROJEKT NR. A97-52046	LOC A1	DIST -	REVISIONS			
P.	LTN.	DESCRIPTION	DATE	DMN	APVD			
-	-	SEE SHEET 1	-	-	-			

## ADDITIONAL CODINGS / Zusätzliche Kodierungen

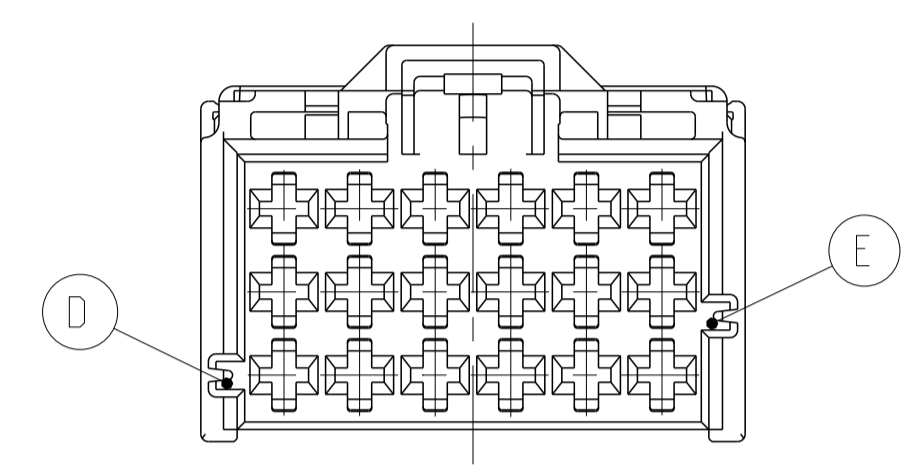
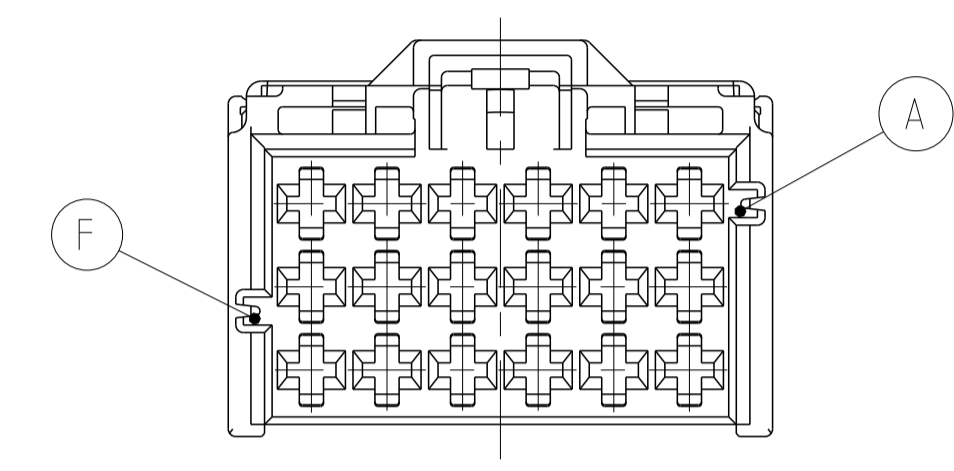

CODING / Kodierung F			MECHANICAL CODING: mechanische Kodierung:	
RIBS / Nuten: A-F				
9-968975-2	F		21 POS. pol.	PBT-GF15
9-968974-2	F		18 POS. pol.	
			15 POS. pol.	
9-968972-2	F	ORANGE	12 POS. pol.	
			9 POS. pol.	
9-968970-2	F		6 POS. pol.	
CUSTOMER PART NUMBER Kunden-Einzelteil-Nummer	TE ORDER-NO. TE Bestell-Nr.	REV.	DESCRIPTION Benennung Einzelteil	MATERIAL Werkstoff

F

CODING / Kodierung E			MECHANICAL CODING: mechanische Kodierung:	
RIBS / Nuten: E-D				
4-968975-1	F		21 POS. pol.	PBT-GF15
4-968974-1	F		18 POS. pol.	
			15 POS. pol.	
4-968972-1	F	EMERALD GREEN	12 POS. pol.	
			9 POS. pol.	
4-968970-1	F		6 POS. pol.	
CUSTOMER PART NUMBER Kunden-Einzelteil-Nummer	TE ORDER-NO. TE Bestell-Nr.	REV.	DESCRIPTION Benennung Einzelteil	MATERIAL Werkstoff

F

THIS DRAWING IS A CONTROLLED DOCUMENT.		DMN R. Huebner	19JAN1998		TE Connectivity
DIMENSIONS: mm		CHK J. Haas	19JAN1998		
	TOLERANCES UNLESS OTHERWISE SPECIFIED: H, DR 9001 - 90	APVD M. Bleicher	18JAN2008	NAME PRODUCT GROUP DRAWING FOR: AMP MCP 2.8 HSG. 6-21POS. WITH SECONDARY LOCKING DEVICE Produkt-Gruppen-Zeichnung fuer: AMP MCP 2.8 Gehaeuse. 6-21polig mit zweiter Kontaktsicherung	
	MATERIAL SEE PARTS LIST	FINISH SEE PARTS LIST	WEIGHT SEE TABLE	SIZE A1	CAGE CODE 00779
CUSTOMER DRAWING			SCALE 2:1	SHEET 2	OF 2
			REV F		

# Mouser Electronics

Authorized Distributor

Click to View Pricing, Inventory, Delivery & Lifecycle Information:

[TE Connectivity:](#)

[6-968970-1](#)