

REVISIONS				
P	LR	DESCRIPTION	DATE	APPV
J4		REVISED PER ECO-11-004820	11MAR11	RK HMR
J5		REVISED PER ECO-19-015225	16OCT2019	RS JO

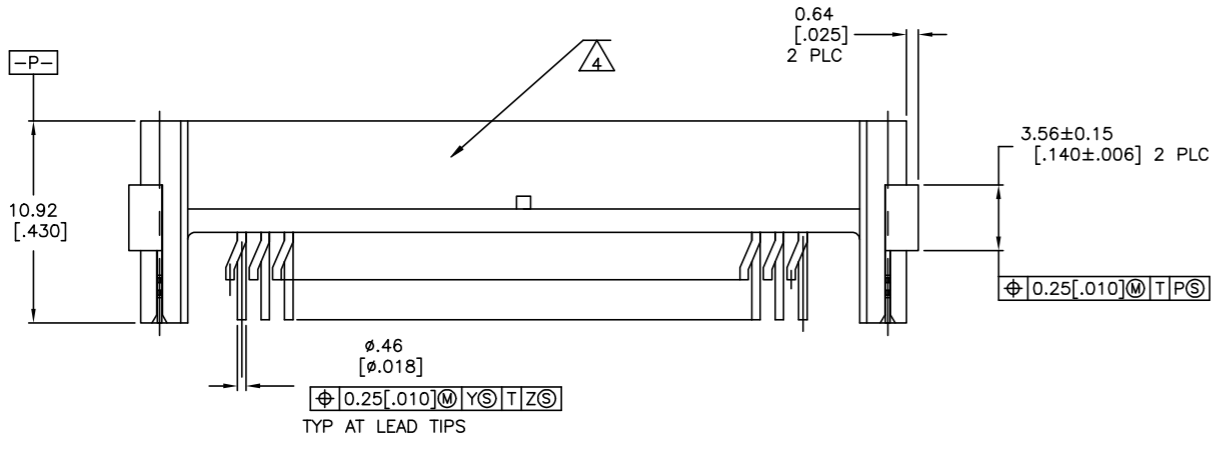

- 1 0.00076 [.000030] GOLD IN LOCALIZED PLATE AREA 0.00381 [.000150] TIN-LEAD ON SOLDER LEADS ALL OVER 0.00127 [.000050] NICKEL
- 2 USE 1.32±0.02 [.0520±.0010] DRILLED HOLE (#55 DRILL) FINISH TO BE TIN-LEAD OVER 0.02 [.001] MIN COPPER
- 3 PLATING: 0.0038 [.000150] TIN-LEAD OVER 0.00127 [.000050] NICKEL
- 4 SERRATIONS OPTIONAL THIS SURFACE.
- 5 0.00076 [.000030] GOLD IN LOCALIZED PLATE AREA 0.00381 [.000150] TIN ON SOLDER LEADS ALL OVER 0.00127 [.000050] NICKEL
- 6 PRELIMINARY PART - NOT RELEASED FOR PRODUCTION.
- 7 PLATING: 0.0038 (.00015) TIN OVER .00127 (.000050) NICKEL.
- 8 USE 1.32+/-0.02 (.052+/-0.0010) DRILLED HOLE (#55 DRILL) FINISH TO BE TIN OVER 0.02 (.001) MIN COPPER
- 9 ROHS 2002/95/EC COMPLIANT.
- 10 OBSOLETE PARTS: OBSOLETE CIS STREAMLINING PER D.RENAUD/D.SINISI

FINISH	NO. OF SPA (SEE DETAIL R)	D	C	B	A	NUMBER OF POSITIONS	PART NUMBER		
9	5	7	49	71.12 [2.800]	62.87 [2.475]	99	73.15 [2.880]	100	6-104894-0
9	5	7	44	64.77 [2.550]	56.52 [2.225]	89	66.80 [2.630]	90	5-104894-9
10	9	9	39	58.42 [2.300]	50.17 [1.975]	79	60.45 [2.380]	80	5-104894-8
9	5	7	34	52.07 [2.050]	43.82 [1.725]	69	54.10 [2.130]	70	5-104894-7
9	5	7	29	45.72 [1.800]	37.47 [1.475]	59	47.75 [1.880]	60	5-104894-6
9	5	7	24	39.37 [1.550]	31.12 [1.225]	49	41.40 [1.630]	50	5-104894-5
9	5	7	19	33.02 [1.300]	24.77 [0.975]	39	35.05 [1.380]	40	5-104894-4
9	5	7	14	26.67 [1.050]	18.42 [0.725]	29	28.70 [1.130]	30	5-104894-3
9	5	7	9	20.32 [0.800]	12.07 [0.475]	19	22.35 [0.880]	20	5-104894-2
9	5	7	4	13.97 [0.550]	5.72 [0.225]	9	16.00 [0.630]	10	5-104894-1
6	5	7	24	39.37 [1.550]	31.12 [1.225]	49	41.40 [1.630]	50	1-104894-5
6	5	7	14	26.67 [1.050]	18.42 [0.725]	29	28.70 [1.130]	30	1-104894-3
1	3	3	49	71.12 [2.800]	62.87 [2.475]	99	73.15 [2.880]	100	1-104894-0
1	3	3	44	64.77 [2.550]	56.52 [2.225]	89	66.80 [2.630]	90	104894-9
1	3	3	39	58.42 [2.300]	50.17 [1.975]	79	60.45 [2.380]	80	104894-8
1	3	3	34	52.07 [2.050]	43.82 [1.725]	69	54.10 [2.130]	70	104894-7
1	3	3	29	45.72 [1.800]	37.47 [1.475]	59	47.75 [1.880]	60	104894-6
1	3	3	24	39.37 [1.550]	31.12 [1.225]	49	41.40 [1.630]	50	104894-5
1	3	3	19	33.02 [1.300]	24.77 [0.975]	39	35.05 [1.380]	40	104894-4
1	3	3	14	26.67 [1.050]	18.42 [0.725]	29	28.70 [1.130]	30	104894-3
1	3	3	9	20.32 [0.800]	12.07 [0.475]	19	22.35 [0.880]	20	104894-2
1	3	3	4	13.97 [0.550]	5.72 [0.225]	9	16.00 [0.630]	10	104894-1

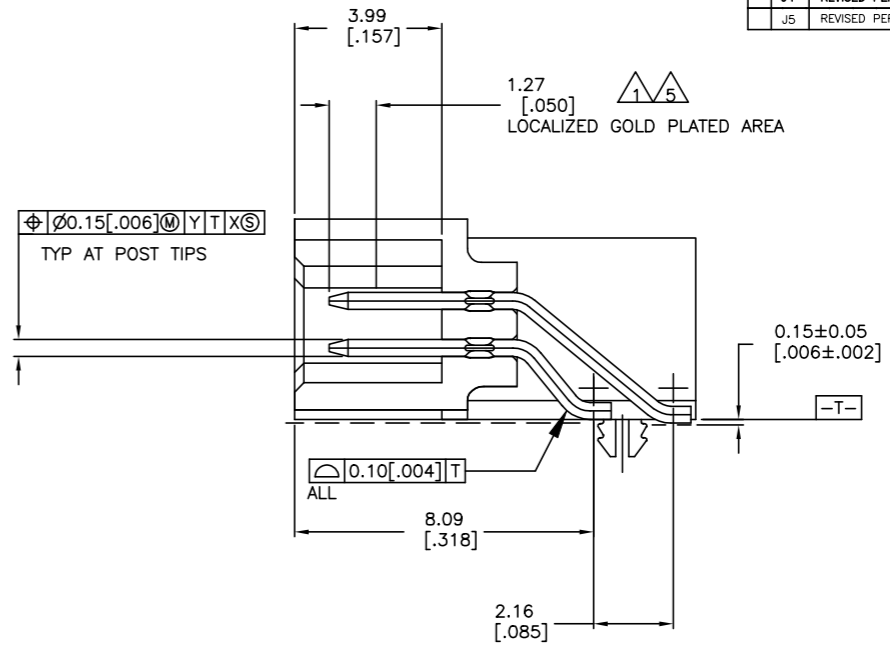
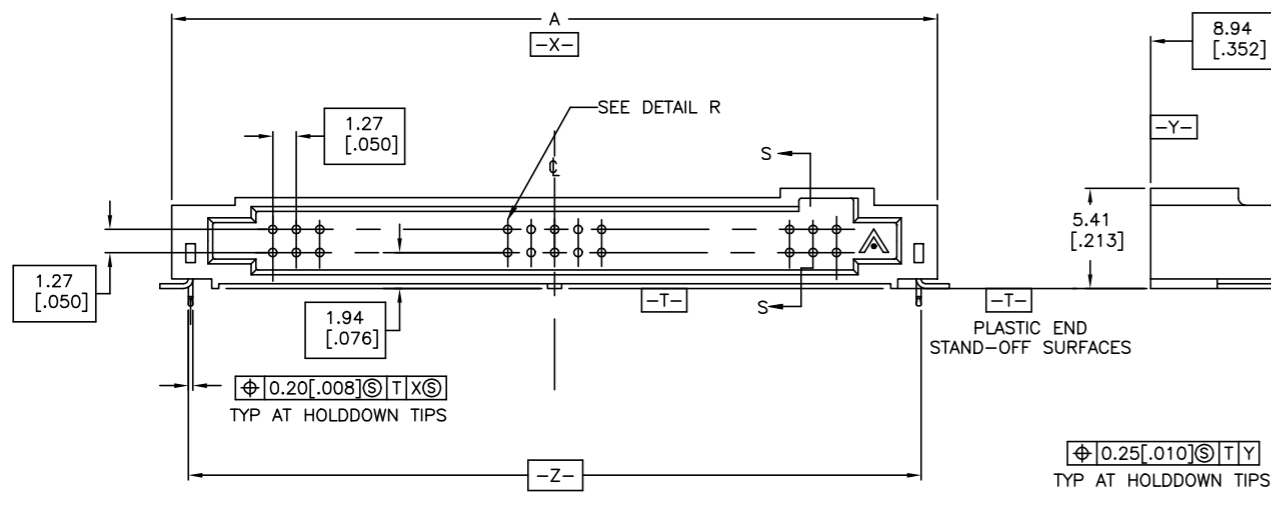
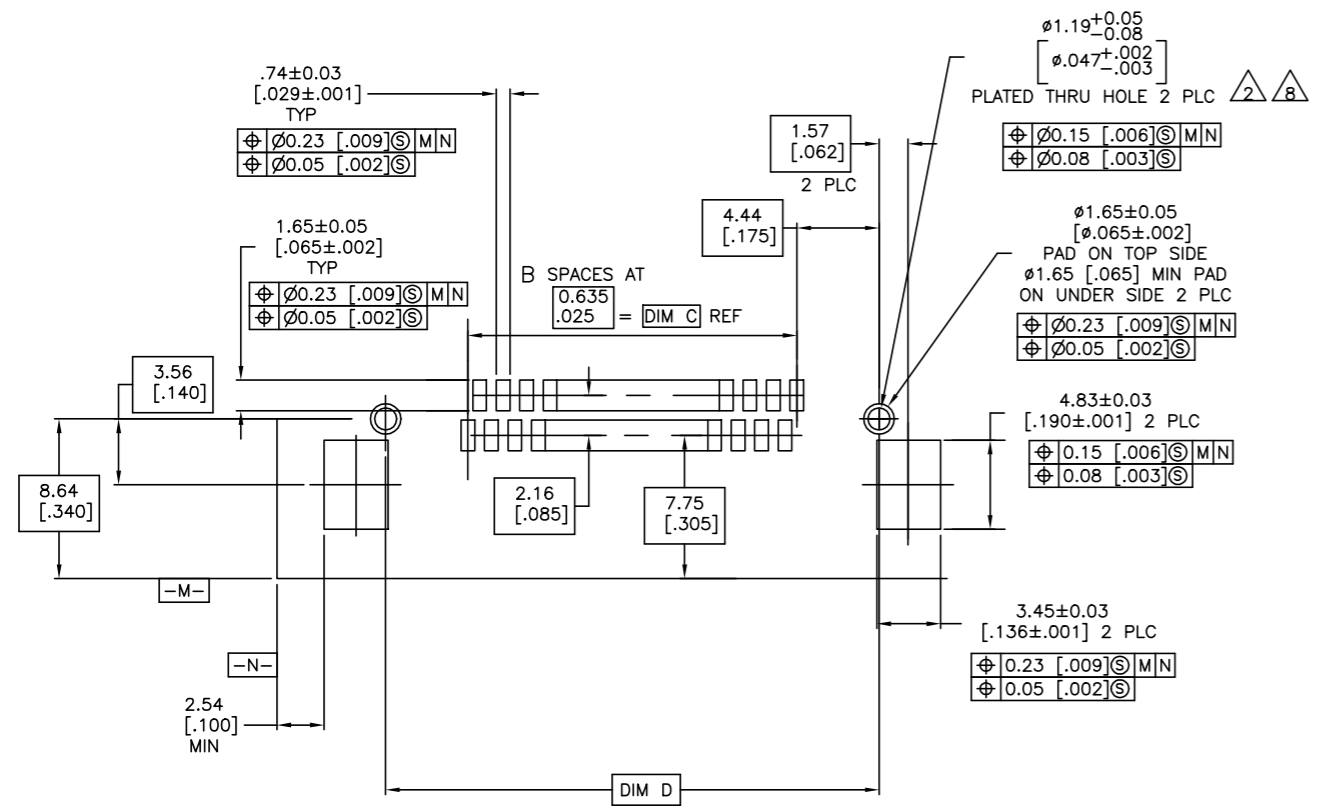

BASIC DIMENSIONS FOR ODD NO OF SPACES (SEE TABLE)

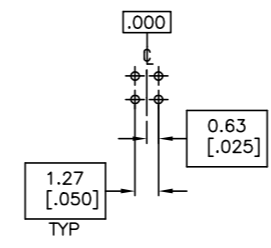

BASIC DIMENSIONS FOR EVEN NO OF SPACES (SEE TABLE)

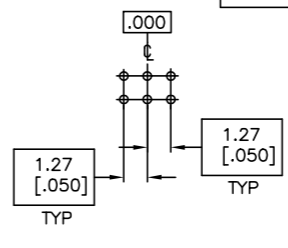

RECOMMENDED BOARD LAYOUT SCALE 5:1

DETAIL R

THIS DRAWING IS A CONTROLLED DOCUMENT. DWG: J.HERRINGTON 18-6-93. CHK: P.SREMCICH 24-6-93. APPV: D.DUPLER 24-6-93. NAME: ASSEMBLY, HEADER, RIGHT ANGLE, DOUBLE ROW, AMPMODU 50/50 GRID CONNECTOR.

MATERIAL: LCP, COLOR: BLACK. CONTACTS: BRASS. HOLDDOWN: COPPER ALLOY. FINISH: SEE TABLE.

WEIGHT: 0.000000. CUSTOMER DRAWING: 114-7010. SIZE: A1. CASE CODE: 00779. DRAWING NO: 104894. SCALE: 5:1. SHEET: 1 OF 1. REV: J5.

# Mouser Electronics

Authorized Distributor

Click to View Pricing, Inventory, Delivery & Lifecycle Information:

[TE Connectivity:](#)

[1-104894-5](#)