

REVISIONS					
P	LTR	DESCRIPTION	DATE	DWN	APVD
R		REVISED PER ECO-17-002210	10APR2017	RS	MM
S		REVISED PER ECO-20-001323	19JUN2020	SM	JO

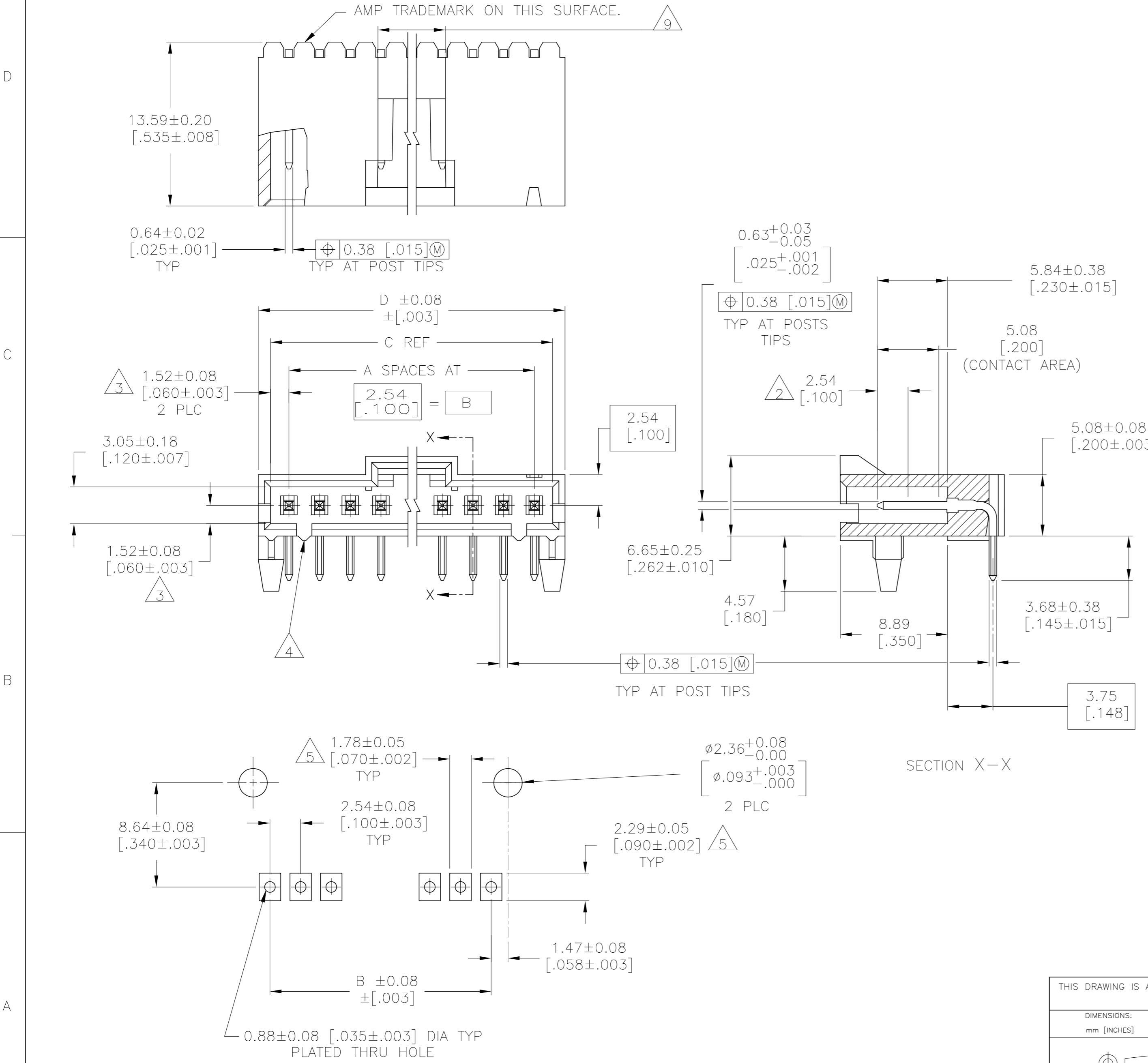

- 1 0.000381 [.000015] GOLD IN THE CONTACT AREA, 0.00254-0.00508 [.000100-.000200] MATTE TIN-LEAD ON THE SOLDER TAIL, ALL OVER 0.00127 [.000050] NICKEL.
- 2 POINT OF MEASUREMENT FOR PLATING THICKNESS
- 3 THE NOTED DIMENSIONS APPLY FROM THE BASIC DIMENSION LINE (NOT THE POST CENTERLINE) TO THE SURFACE INDICATED
- 4 ON ASSEMBLIES WITH FOUR OR MORE POSITIONS, TWO POLARIZATION SLOTS. ON ASSEMBLIES WITH TWO OR THREE POSITIONS, ONE POLARIZATION SLOT.
- 5 DIMENSIONS NOTED ARE FOR SOLDER STENCIL LAYOUT FOR USE WITH A 1.57±0.20 [.062±.008] THICK. PRINTED CIRCUIT BOARD
- 6 PARTS ARE PACKAGED IN GANG OF TUBES
- 7 0.000381 [.000015] GOLD IN THE CONTACT AREA, 0.00254-0.00508 [.000100-.000200] MATTE TIN ON THE SOLDER TAIL, ALL OVER 0.00127 [.000050] NICKEL.
- 8 OBSOLETE PARTS: OBSOLETE CIS STREAMLINING PER D.RENAUD/D.SINISI
- 9 0.25 [.010] RECESS PERMISSIBLE IN THIS AREA FOR MOLD SHUT OFF

SECTION X-X

SEE SHEET 2 FOR PART NUMBER TABLE

RECOMMENDED PC BOARD MOUNTING DIMENSIONS
 RECOMMENDED STENCIL THICKNESS = 0.25 [.010]

THIS DRAWING IS A CONTROLLED DOCUMENT.		DWN G. DOUITY 2-22-88		
DIMENSIONS: mm [INCHES]		CHK T. C. CLARK 2-22-88		
TOLERANCES UNLESS OTHERWISE SPECIFIED:		APVD T. C. CLARK 2-22-88	NAME	
0 PLC ± -		PRODUCT SPEC		
1 PLC ± -		APPLICATION SPEC		
2 PLC ± 0.13 [.005]		WEIGHT		
3 PLC ± -		SCALE		
4 PLC ± -		SHEET		
ANGLES ± -		REV		
FINISH SEE TABLE		CUSTOMER DRAWING		
MATERIAL HOUSING : LCP COLOR : BLACK POSTS : BRASS		A2 00779 C=104361		
		RESTRICTED TO		
		4:1		
		1 of 2		
		S		

THIS DRAWING IS UNPUBLISHED. RELEASED FOR PUBLICATION - , -
 © COPYRIGHT - By - ALL RIGHTS RESERVED.

REVISIONS					
P	LTR	DESCRIPTION	DATE	DWN	APVD
-	-	SEE SHEET 1	-	-	-

PLATING	D	C	B	A	NO OF POSN	ASSEMBLY PART NUMBER
△	65.91 [2.595]	64.01 [2.520]	60.96 [2.400]	24	25	7-104361-4
△	63.37 [2.495]	61.47 [2.420]	58.42 [2.300]	23	24	7-104361-3
△	60.83 [2.395]	58.93 [2.320]	55.88 [2.200]	22	23	7-104361-2
△	58.29 [2.295]	56.39 [2.220]	53.34 [2.100]	21	22	7-104361-1
△	55.75 [2.195]	53.85 [2.120]	50.8 [2.000]	20	21	7-104361-0
△	53.21 [2.095]	51.31 [2.020]	48.26 [1.900]	19	20	6-104361-9
△	50.67 [1.995]	48.77 [1.920]	45.72 [1.800]	18	19	6-104361-8
△	48.13 [1.895]	46.23 [1.820]	43.18 [1.700]	17	18	6-104361-7
△	45.59 [1.795]	43.69 [1.720]	40.64 [1.600]	16	17	6-104361-6
△	43.05 [1.695]	41.15 [1.620]	38.1 [1.500]	15	16	6-104361-5
△	40.51 [1.595]	38.61 [1.520]	35.56 [1.400]	14	15	6-104361-4
△	37.97 [1.495]	36.07 [1.420]	33.02 [1.300]	13	14	6-104361-3
△	35.43 [1.395]	33.53 [1.320]	30.48 [1.200]	12	13	6-104361-2
△	32.89 [1.295]	30.99 [1.220]	27.94 [1.100]	11	12	6-104361-1
△	30.35 [1.195]	28.45 [1.120]	25.4 [1.000]	10	11	6-104361-0
△	27.81 [1.095]	25.91 [1.020]	22.86 [.900]	9	10	5-104361-9
△	25.27 [.995]	23.37 [.920]	20.32 [.800]	8	9	5-104361-8
△	22.73 [.895]	20.83 [.820]	17.78 [.700]	7	8	5-104361-7
△	20.19 [.795]	18.29 [.720]	15.24 [.600]	6	7	5-104361-6
△	17.65 [.695]	15.75 [.620]	12.7 [.500]	5	6	5-104361-5
△	15.11 [.595]	13.21 [.520]	10.16 [.400]	4	5	5-104361-4
△	12.57 [.495]	10.67 [.420]	7.62 [.300]	3	4	5-104361-3
△	10.03 [.395]	8.13 [.320]	5.08 [.200]	2	3	5-104361-2
△	7.49 [.295]	5.59 [.220]	2.54 [.100]	1	2	5-104361-1
△	65.91 [2.595]	64.01 [2.520]	60.96 [2.400]	24	25	2-104361-4
△	63.37 [2.495]	61.47 [2.420]	58.42 [2.300]	23	24	2-104361-3
△	60.83 [2.395]	58.93 [2.320]	55.88 [2.200]	22	23	2-104361-2
△	58.29 [2.295]	56.39 [2.220]	53.34 [2.100]	21	22	2-104361-1
△	55.75 [2.195]	53.85 [2.120]	50.8 [2.000]	20	21	2-104361-0
△	53.21 [2.095]	51.31 [2.020]	48.26 [1.900]	19	20	1-104361-9
△	50.67 [1.995]	48.77 [1.920]	45.72 [1.800]	18	19	1-104361-8
△	48.13 [1.895]	46.23 [1.820]	43.18 [1.700]	17	18	1-104361-7
△	45.59 [1.795]	43.69 [1.720]	40.64 [1.600]	16	17	1-104361-6
△	43.05 [1.695]	41.15 [1.620]	38.1 [1.500]	15	16	1-104361-5
△	40.51 [1.595]	38.61 [1.520]	35.56 [1.400]	14	15	1-104361-4
△	37.97 [1.495]	36.07 [1.420]	33.02 [1.300]	13	14	1-104361-3
△	35.43 [1.395]	33.53 [1.320]	30.48 [1.200]	12	13	1-104361-2
△	32.89 [1.295]	30.99 [1.220]	27.94 [1.100]	11	12	1-104361-1
△	30.35 [1.195]	28.45 [1.120]	25.4 [1.000]	10	11	1-104361-0
△	27.81 [1.095]	25.91 [1.020]	22.86 [.900]	9	10	104361-9
△	25.27 [.995]	23.37 [.920]	20.32 [.800]	8	9	104361-8
△	22.73 [.895]	20.83 [.820]	17.78 [.700]	7	8	104361-7
△	20.19 [.795]	18.29 [.720]	15.24 [.600]	6	7	104361-6
△	17.65 [.695]	15.75 [.620]	12.7 [.500]	5	6	104361-5
△	15.11 [.595]	13.21 [.520]	10.16 [.400]	4	5	104361-4
△	12.57 [.495]	10.67 [.420]	7.62 [.300]	3	4	104361-3
△	10.03 [.395]	8.13 [.320]	5.08 [.200]	2	3	104361-2
△	7.49 [.295]	5.59 [.220]	2.54 [.100]	1	2	104361-1

△ SUPERSEDED BY 7-104361-4
 △ SUPERSEDED BY 7-104361-3
 △ SUPERSEDED BY 7-104361-2
 △ SUPERSEDED BY 7-104361-1
 △ SUPERSEDED BY 7-104361-0
 △ SUPERSEDED BY 6-104361-8
 △ SUPERSEDED BY 6-104361-7
 △ SUPERSEDED BY 6-104361-6
 △ SUPERSEDED BY 6-104361-5
 △ SUPERSEDED BY 6-104361-4
 △ SUPERSEDED BY 6-104361-2
 △ SUPERSEDED BY 6-104361-0

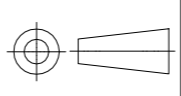
THIS DRAWING IS A CONTROLLED DOCUMENT.		DWN G. DOUTY 2-22-88	 TE Connectivity	
DIMENSIONS: mm [INCHES]		CHK T. C. CLARK 2-22-88		
		APVD T. C. CLARK 2-22-88	HEADER ASSY, AMPMODU MTE, RIGHT ANGLE, SINGLE ROW, .100 POSTS, WITH LATCH & HOLD DOWNS	
MATERIAL HOUSING : LCP COLOR : BLACK POSTS : BRASS		PRODUCT SPEC	SIZE A2	CAGE CODE 00779
FINISH SEE TABLE		APPLICATION SPEC	DRAWING NO 104361	RESTRICTED TO
		WEIGHT	SCALE 4:1	SHEET 2 of 2
		CUSTOMER DRAWING	REV S	

Mouser Electronics

Authorized Distributor

Click to View Pricing, Inventory, Delivery & Lifecycle Information:

[TE Connectivity:](#)

[5-104361-1](#)