

| | |
|--------------------------------------|------------------|
| SPECIFICATION CONTROL DRAWING | 0022S2662 |
|--------------------------------------|------------------|

| | | | |
|-----------------|--|----------|---------|
| CHEMINAX | 100 OHM, AWG 22, 19 STRANDS OF AWG 34, TWINAXIAL CABLE, OUTER SPACE USE | Date | 1-10-12 |
| | | Revision | A |

THIS SPECIFICATION SHEET FORMS A PART OF THE LATEST ISSUE OF RAYCHEM SPECIFICATION 1200.

| | |
|-----------------------------|-----------------------------------|
| CONSTRUCTION DETAILS | ELECTRICAL CHARACTERISTICS |
|-----------------------------|-----------------------------------|

DIMENSIONS ARE NOMINAL VALUES IN INCHES UNLESS OTHERWISE DESIGNATED.

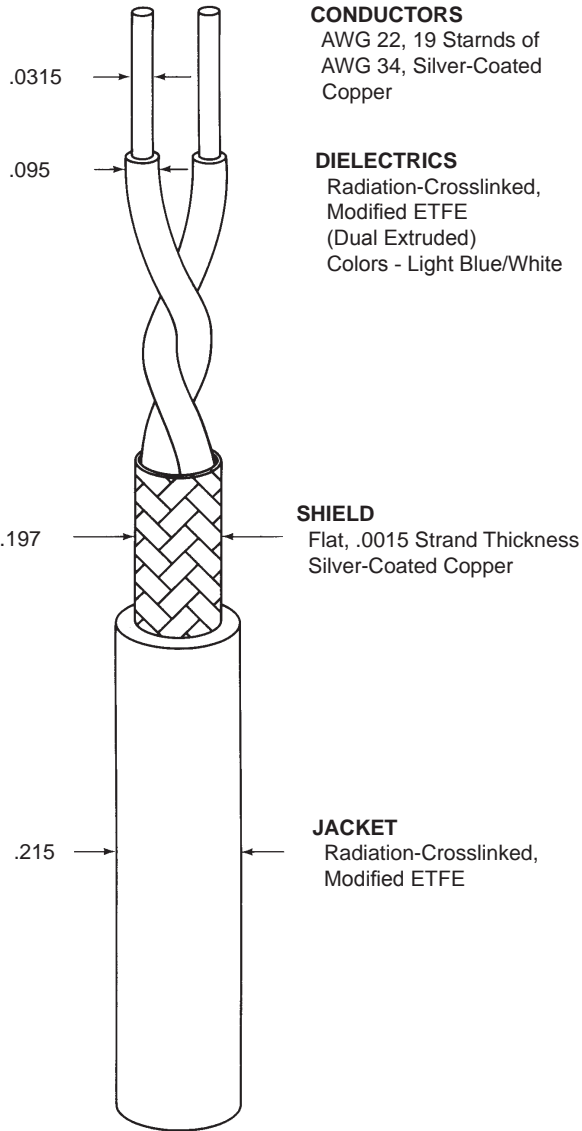

| | |
|--------------------------|----------------------------------|
| CHARACTERISTIC IMPEDANCE | 100 ± 10 ohms, Method C at 1 MHz |
| MUTUAL CAPACITANCE | 18 pF/ft. (nominal) |

ADDITIONAL REQUIREMENTS

COMPONENT WIRE PRIOR TO CABLING (Test Procedures per SAE AS22759)

| | |
|--------------------------------|--|
| CROSSLINKING PROOF TEST | 300 ± 3°C for 1 hour, 1.00 inch mandrel, 1.00 lb., 2.5 kV dielectric test |
| INSULATION (DIELECTRIC) | |
| ELONGATION | 50% (minimum) |
| TENSILE STRENGTH | 5000 lbf/in ² (minimum) |
| INSULATION FLAWS | |
| SPARK TEST | 3.0 kV (rms) |
| IMPULSE TEST | 8.0 kV (peak) |
| INSULATION RESISTANCE | 5000 megohms for 1000 ft. (minimum) |
| LOW TEMPERATURE-COLD BEND | -65 ± 3°C for 4 hours, .750 inch mandrel, 1.00 lb., 2.5 kV dielectric test |
| SHRINKAGE | 200 ± 3°C for 1 hour, .125 inch (maximum) in 12 inches |

FINISHED CABLE (Test Procedures per NEMA WC 27500, unless otherwise specified)

| | |
|--------------------------------------|--|
| BLOCKING | 200°C for 6 hours |
| CROSSLINKED VERIFICATION | 300 ± 5°C for 6 hours, 6.00 inch mandrel |
| FLAMMABILITY (Method B of Spec 1200) | 3 seconds (maximum); 3 inches (maximum); no flaming of facial tissue |
| JACKET | |
| ELONGATION | 50% (minimum) |
| TENSILE STRENGTH | 5000 lbf/in ² (minimum) |
| JACKET FLAWS | |
| SPARK TEST | 1.0 kV (rms) |
| IMPULSE TEST | 6.0 kV (peak) |
| JACKET THICKNESS | .009 inch (nominal) |
| LOW TEMPERATURE-COLD BEND | -55 ± 5°C for 4 hours, 6.00 inch mandrel |
| SHIELD COVERAGE | 90% (minimum) |
| VOLTAGE WITHSTAND (DIELECTRIC) | 1500 volts (rms) |
| WEIGHT | 23.5 lbs/1000 ft. (nominal) |

OUTER SPACE REQUIREMENTS

| | |
|-------------------------------------|--|
| RADIATION RESISTANCE | 500 megarads/6.50 inch mandrel 1.0 kV dielectric test |
| VACUUM STABILITY | |
| TOTAL MASS LOSS (TML) | 1.00% (maximum) |
| VOLATILE CONDENSABLE MATERIAL (VCM) | 0.10% (maximum) |
| WEIGHT LOSS (Per Raychem Spec 55/): | 0.45% (maximum) |

Outer jacket color will be white (designated by a "-9" appended to the part number, e.g. 0022S2662-9) unless otherwise specified.

Designate outer jacket color with a dash number in accordance with MIL-STD-681. Other codes and suffixes may be added to the part number, as necessary, to capture any additional requirements imposed by the purchase order.

Users should evaluate the suitability of this product for their application. Specifications are subject to change without notice. Tyco Electronics Corporation also reserves the right to make changes in materials or processing, which do not affect compliance with any specification, without notification to Buyer.



Raychem Wire & Cable
501 Oakside Avenue
Redwood City, California 94063-3800
1-800-227-8816 Fax: 1-650-361-6297

THIS SPECIFICATION SHEET TAKES PRECEDENCE OVER DOCUMENTS REFERENCED HEREIN. REFERENCED DOCUMENTS SHALL BE OF THE ISSUE IN EFFECT ON DATE OF INVITATION FOR BID.

Mouser Electronics

Authorized Distributor

Click to View Pricing, Inventory, Delivery & Lifecycle Information:

[TE Connectivity:](#)

[CX5277-000](#)