

PROPER USE GUIDELINES

Cumulative Trauma Disorders can result from the prolonged use of manually powered hand tools. Hand tools are intended for occasional use and low volume applications. A wide selection of powered application equipment for extended-use, production operations is available.

1. INTRODUCTION

ROTA-CRIMP Hand Crimping Tools 600850 and 600850-1 (shown in Figure 1) are used to apply SOLISTRAND* terminals and splices, Tubular terminals and splices, and CABLE MAKER* battery terminals onto stranded copper wire. Product CMA (circular mil area), applicable wire sizes, and wire strip lengths are provided in Figures 2 and 3.

NOTE Dimensions in this instruction sheet are in metric units [with U.S. customary units in brackets]. Figures are not drawn to scale.

DANGER Do NOT use these tools on aircraft applications or on aluminum wire terminations.

DANGER Tool must be stored with the dies in the E-A (1/0) position to eliminate tension on the handles.

Reasons for reissue of this instruction sheet are provided in Section 8, REVISION SUMMARY.

2. DESCRIPTION (Figure 1)

The hand crimping tools feature two rotating crimping dies that are held in place by spring-loaded indexing pins. Each die is positioned using a spring-loaded die locator pin. Wire size designations are embossed on the crimping dies to ensure proper setting of the crimping area, and a die order chart is included on the tool for reference. The dies are positioned according to the die order chart as shown in Figure 1.

3. CRIMPING PROCEDURE

For Tubular and SOLISTRAND Terminals and Splices

3.1. Die Setting

1. Open the tool handles.
2. Check the die order chart on the tool and select the left (L) and right (R) die letters for the wire size being used. Refer to Figure 1.
3. Depress the spring-loaded indexing pins and rotate the desired size dies into crimping position. The embossed die letters must match as shown in Figure 1.
4. When the correct size dies are in position, release the indexing pins. Make sure that the die locator pins return fully to their seated position and are visible at the points indicated in Figure 1.

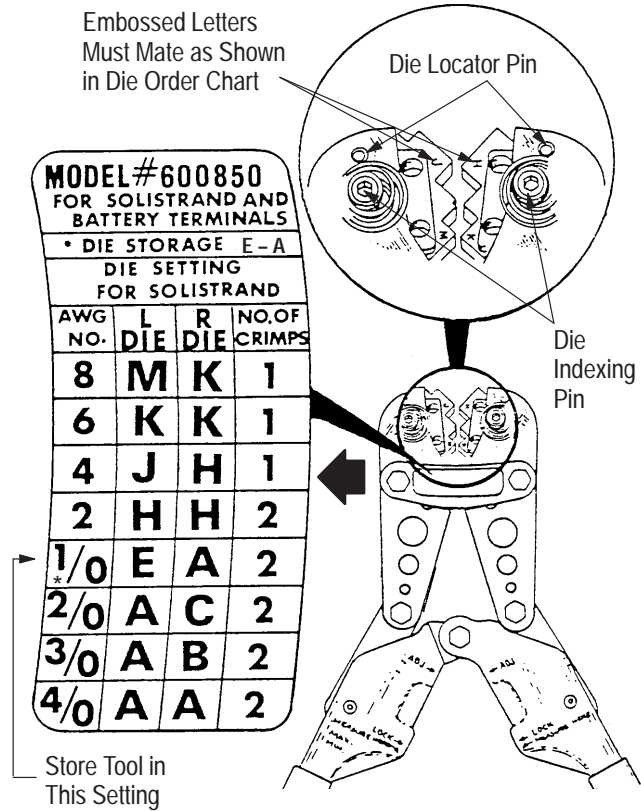

Die Order Chart

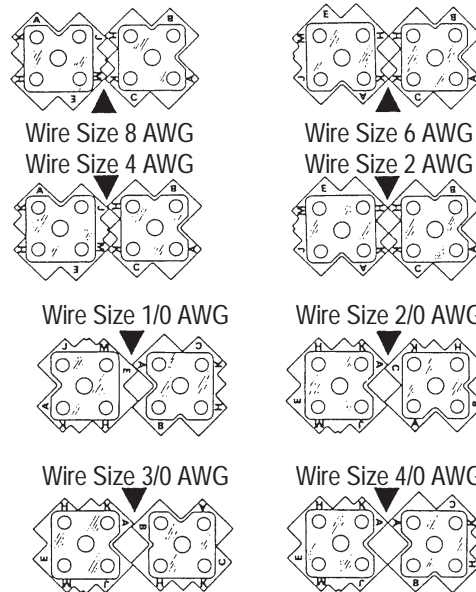

Figure 1

SOLISTRAND Terminals and Splices



Ring Terminal



Butt Splice



Parallel Splice

TERMINAL OR SPLICE WIRE SIZE RANGE (mm ² [CMA])	APPROX WIRE SIZE (AWG)	WIRE STRIP LENGTH (mm [in.])					
		TERMINAL		BUTT SPLICE		PARALLEL SPLICE	
		MIN	MAX	MIN	MAX	MIN	MAX
6.6-10.5 [13,100-20,800]	8	8.33 [.328]	9.12 [.359]	10.32 [.406]	11.11 [.438]	10.32 [.406]	11.11 [.438]
10.5-16.7 [20,800-33,100]	6	9.92 [.391]	10.71 [.422]	11.90 [.469]	12.70 [.50]	11.11 [.438]	11.90 [.469]
16.7-26.6 [33,100-52,600]	4	11.50 [.453]	12.30 [.484]	13.49 [.531]	14.28 [.562]	13.49 [.531]	14.28 [.562]
26.6-42.4 [52,600-83,700]	2	13.09 [.515]	13.89 [.547]	15.08 [.594]	15.87 [.625]	15.08 [.594]	15.87 [.625]
42.4-60.5 [83,700-119,500]	1/0	18.65 [.734]	20.24 [.797]	15.87 [.625]	17.46 [.688]	17.46 [.688]	19.05 [.75]
60.5-76.2 [119,500-150,500]	2/0	18.65 [.734]	20.24 [.797]	15.87 [.625]	17.46 [.688]	17.46 [.688]	19.05 [.75]
76.2-96.2 [150,500-190,000]	3/0	19.05 [.75]	20.63 [.812]	17.46 [.688]	19.05 [.75]	17.46 [.688]	19.05 [.75]
96.2-117.0 [190,000-231,000]	4/0	19.44 [.765]	20.63 [.812]	17.46 [.688]	19.05 [.75]	19.05 [.75]	20.63 [.812]

Figure 2

Tubular Terminals and Splices



Ring Terminal



Butt Splice



Parallel Splice

TERMINAL OR SPLICE WIRE SIZE RANGE (mm ² [CMA])	APPROX WIRE SIZE (AWG)	WIRE STRIP LENGTH (mm [in.])							
		TERMINAL		IN-LINE SPLICE		BUTT SPLICE		PARALLEL SPLICE	
		MIN	MAX	MIN	MAX	MIN	MAX	MIN	MAX
6.6-10.5 [13,100-20,800]	8	19.05 [.75]	19.84 [.781]	—	—	19.84 [.781]	20.63 [.812]	19.05 [.75]	19.84 [.781]
10.5-16.7 [20,800-33,100]	6	19.05 [.75]	19.84 [.781]	—	—	19.84 [.781]	20.63 [.812]	19.05 [.75]	19.84 [.781]
16.7-26.6 [33,100-52,600]	4	19.05 [.75]	19.84 [.781]	—	—	19.84 [.781]	20.63 [.812]	19.05 [.75]	19.84 [.781]
26.6-42.4 [52,600-83,700]	2	19.05 [.75]	19.84 [.781]	—	—	22.22 [.875]	23.02 [.906]	22.22 [.875]	23.02 [.906]
42.4-60.5 [83,700-119,500]	1/0	19.05 [.75]	19.84 [.781]	19.05 [.75]	19.84 [.781]	23.81 [.938]	24.60 [.906]	22.22 [.875]	23.02 [.906]
60.5-76.2 [119,500-150,500]	2/0	19.05 [.75]	19.84 [.781]	19.05 [.75]	19.84 [.781]	24.60 [.969]	25.40 [1.00]	22.22 [.875]	23.02 [.906]
76.2-96.2 [150,500-190,000]	3/0	20.63 [.812]	21.43 [.844]	20.63 [.812]	21.43 [.844]	26.19 [1.031]	26.98 [1.062]	25.40 [1.00]	26.19 [1.031]
96.2-117.0 [190,000-231,000]	4/0	20.63 [.812]	21.43 [.844]	20.63 [.812]	21.43 [.844]	32.54 [1.281]	33.33 [1.312]	25.40 [1.00]	26.19 [1.031]

Figure 3

3.2. Wire Preparation and Loading

1. Strip the wire(s) to the dimensions indicated in either Figure 2 or Figure 3. Do NOT use wires with nicked or missing strands.
2. Select the proper size terminal or splice for the wire size being used.
3. Determine the correct terminal or splice wire loading by referring to the terminal or splice wire size range listed in Figure 2 or Figure 3. The total area of the wires being used must be within the terminal or splice specified range.

3.3. Performing Single Crimp on Terminals and Splices With Wire Sizes 8 through 4 AWG (Figure 4)

NOTE *Make sure that the wire size stamped on the terminal or splice corresponds with the wire size code embossed on the tool dies.*

1. Center the wire barrel of the terminal or splice in the dies. For best results, position the brazed seam of SOLISTRAND terminals against one of the “flats” of the dies, as shown in Figure 4.
2. Close the tool handles until the terminal or splice is held firmly in place. Do not deform the wire barrel.
3. Insert the stripped wire into the terminal or splice until the wire conductor is at least flush with, or is extending beyond, the end of the wire barrel, as shown in Figure 4.
4. Close the tool handles until the handles bottom. Open the handles and remove the crimped terminal or splice.
5. If crimping a butt splice, repeat the procedure for the opposite end of the splice.
6. Refer to Section 5, CRIMP INSPECTION, to inspect the terminal or splice crimp.

3.4. Performing Dual Crimp on Terminals and Splices With Wire Sizes 2 through 4/0 AWG (Figure 5)

NOTE *Make sure that the wire size being used, the wire size stamped on the terminal or splice, and the wire size code embossed on the dies all correspond.*

A. First Crimp

1. Position the end of the terminal or splice wire barrel in the dies as shown in Figure 5.

NOTE *For best results, position the brazed seam of the SOLISTRAND terminal against one of the “flats” of the dies, as shown in Figure 5. Make sure that the crimps do not overlap or go off either end of the wire barrel.*

2. Close the tool handles until the terminal or splice is held in place. Do not deform the wire barrel.
3. Insert the stripped wire into the terminal or splice wire barrel until the end of the conductor is flush with, or is extended slightly beyond, the wire barrel.
4. Close the tool handles until the handles bottom.

B. Second Crimp

1. Move the terminal or splice into position for the second crimp, then close the tool handles to complete the crimp. Do not overlap the crimps.
2. Refer to Section 5, CRIMP INSPECTION, to inspect the terminal or splice crimp.

3.5. Performing Dual Crimp on Butt Splices With Wire Sizes 2 through 4/0 AWG (Figure 5)

NOTE *Make sure that the wire size being used, the wire size stamped on the butt splice, and the wire size code embossed on the dies all correspond.*

A. First and Second Crimps

1. Position the end of the butt splice wire barrel in the dies.

NOTE *For best results, position the brazed seam of the SOLISTRAND butt splice against one of the “flats” of the dies, as shown in Figure 5. Make sure that the crimps do not overlap or go off either end of the wire barrel.*

2. Close the tool handles until the butt splice is held in place. Do not deform the wire barrel.
3. Insert a properly stripped wire into the first end of the butt splice until the wire bottoms against the splice wire stop.
4. Close the tool handles until the handles bottom.
5. Move the butt splice into position for the second crimp, as shown in Figure 5.
6. Close the tool handles until the handles bottom. Do not overlap the crimps.

B. Third and Fourth Crimps

1. Position the butt splice for the third crimp, as shown in Figure 5.
2. Close the tool handles until the butt splice is held in place. Do not deform the wire barrel.
3. Insert a properly stripped wire into the opposite end of the butt splice until the wire bottoms against the butt splice wire stop.

Crimping Tubular or SOLISTRAND Terminals, Butt Splices, and Parallel Splices

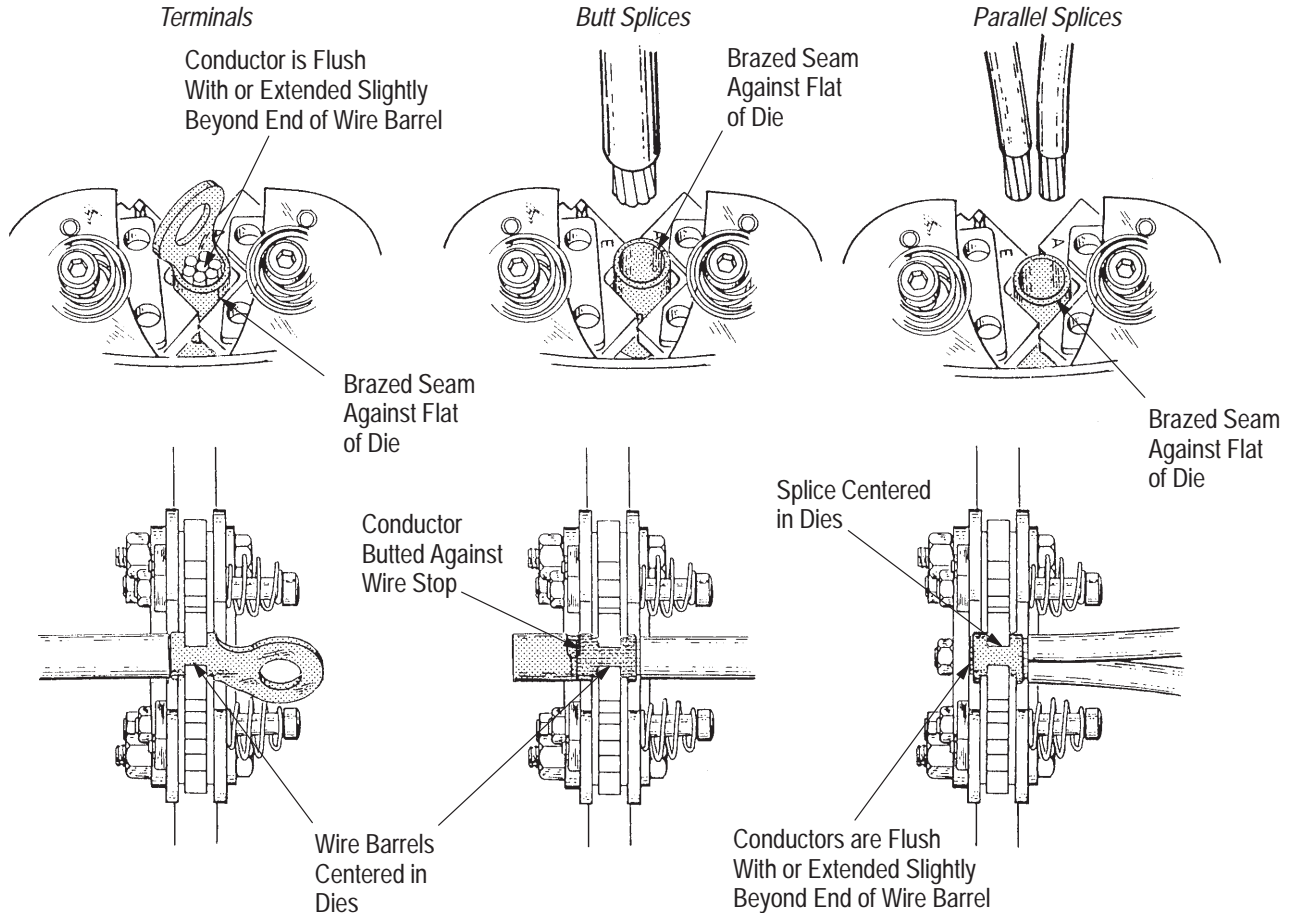

Figure 4

4. Close the tool handles until the handles bottom.
5. Move the butt splice into position for the fourth crimp, as shown in Figure 5.
6. Close the tool handles until the handles bottom. Do not overlap the crimps.
7. Refer to Section 5, CRIMP INSPECTION, to inspect the butt splice crimp.

2. Close the tool handles until the parallel splice is held in place. Do not deform the wire barrel.

3. Insert the properly stripped wire into the wire barrel until the ends of the conductors are flush with, or extended slightly beyond, the end of the wire barrel.

4. Close the tool handles until the handles bottom.

3.6. Performing Dual Crimp on Parallel Splices With Wire Sizes 2 through 4/0 AWG (Figure 5)

NOTE

Make sure that the wire size being used, the wire size stamped on the parallel splice, and the wire size code embossed on the dies all correspond.

A. First Crimp

1. Position the end of the parallel splice wire barrel in the dies.

NOTE

For best results, position the brazed seam of the SOLISTRAND parallel splice against one of the "flats" of the dies, as shown in Figure 5. Make sure that the crimps do not overlap or go off either end of the wire barrel.

B. Second Crimp

1. Move the parallel splice into position for the second crimp and close the tool handles. Do not overlap the crimps.

2. Insert the properly stripped wire into the wire barrel until the ends of the conductors are flush with, or extended slightly beyond, the end of the wire barrel.

3. Refer to Section 5, CRIMP INSPECTION, to inspect the parallel splice crimp.

Crimping Tubular or SOLISTRAND Terminals

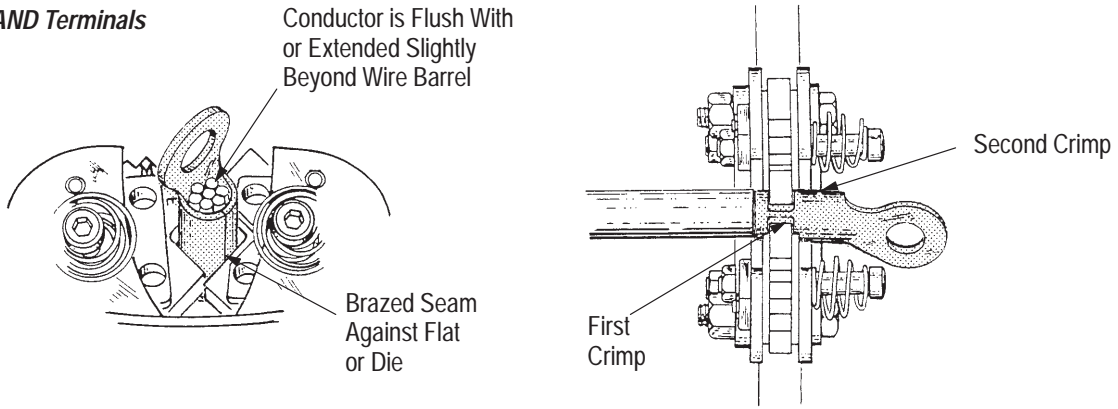

Crimping Tubular or SOLISTRAND Butt Splices

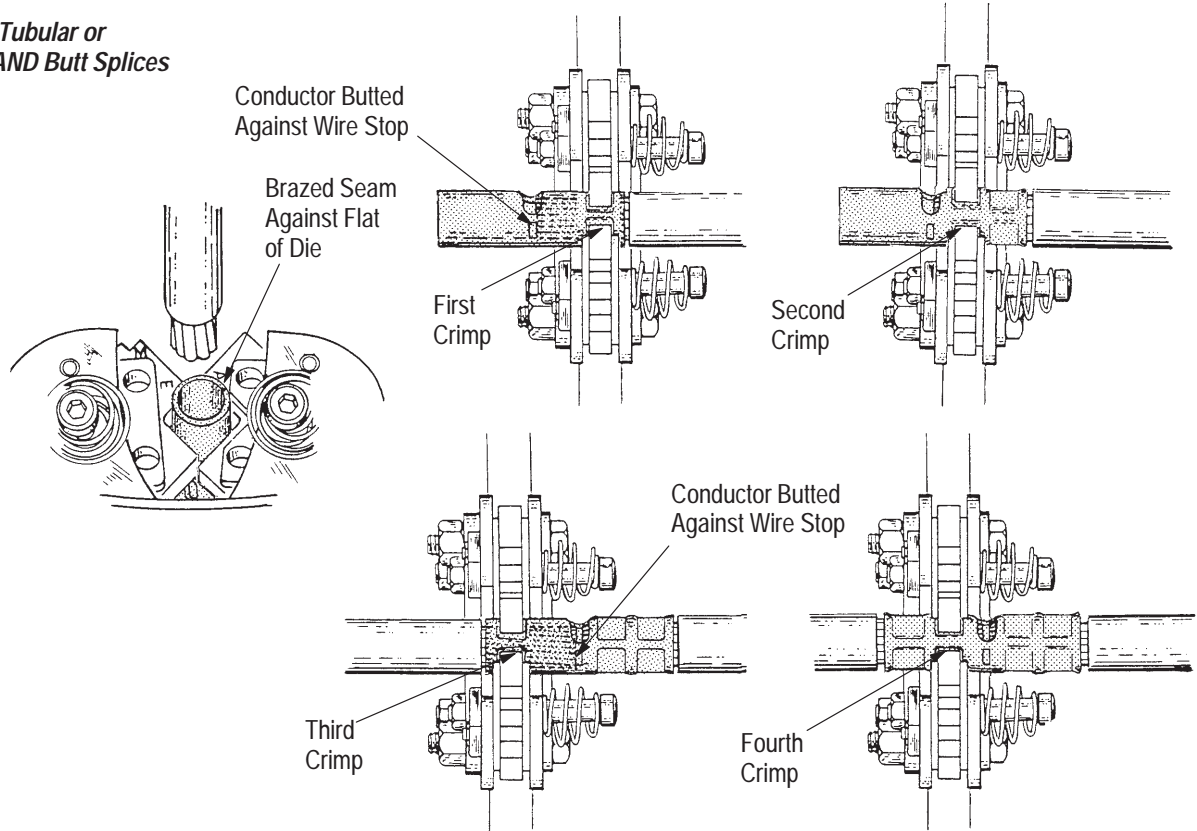

Crimping Tubular or SOLISTRAND Parallel Splices

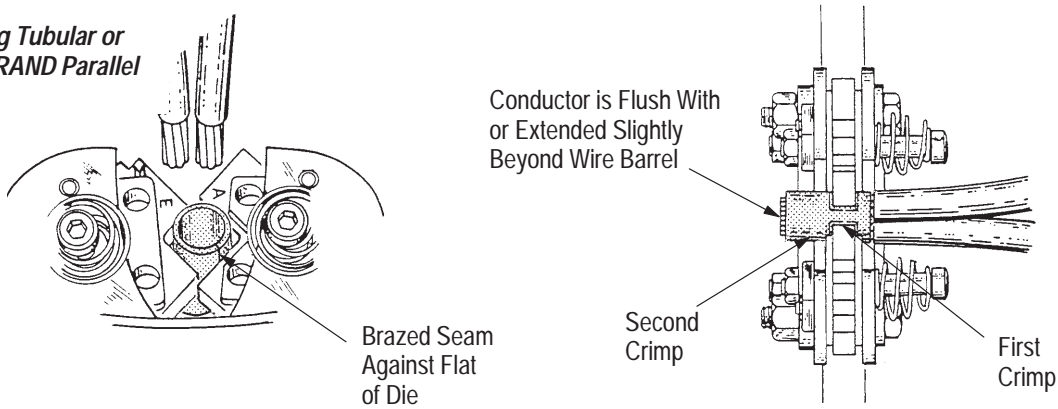

Figure 5

4. CRIMPING PROCEDURE For CABLE MAKER Battery Terminals

4.1. Die Setting

Proper die position is determined by the part number of the terminal being crimped and by the number displayed in Area 1 of the terminal, as shown in Figure 6. To set the die position:

1. Open the tool handles.
2. Depress the spring-loaded index pins.
3. Rotate the dies until the embossed wire size letters in each die crimp area match the code letters displayed in Area 1 of the terminal.
4. Release the indexing pins, making sure that the die locator pins return fully and are visible at the points indicated in Figure 1.

4.2. Wire Preparation and Loading

1. Strip the wires to the dimensions indicated in Figure 6.

CAUTION

Do not use wires with nicked or missing strands.

2. Select the proper terminal for the wire insulation diameter being used. The insulation diameter must fall within the insulation diameter range for the terminal being used. Refer to Figure 6.

4.3. Crimping Straight Terminals (Figure 7)

CAUTION

Make sure that crimps do not overlap or go off the end of the wire barrel.

A. First Crimp

1. Position the end of the straight terminal wire barrel in the dies.
2. Close the tool handles until the straight terminal is held in place. Do not deform the wire barrel.
3. Insert the properly stripped wire into the straight terminal wire barrel until the wire bottoms.
4. Close the tool handles until the dies bottom.

B. Second Crimp

1. Move the straight terminal into position for the second crimp, then close the tool handles.
2. Refer to Section 5, CRIMP INSPECTION, to inspect the straight terminal crimp.

4.4. Crimping Flag Terminals (Figure 7)

CAUTION

Make sure that crimps do not overlap or go off the end of the wire barrel.

A. First Crimp

1. Orient and position the flag terminal in the tool dies as shown in Figure 7.
2. Close the tool handles until the flag terminal is held in place. Do not deform the wire barrel.
3. Insert the properly stripped wire until the end of the conductor is flush with, or extends about 0.79 mm [.0312 in.] beyond, the end of the terminal wire barrel.
4. Close the tool handles until the dies bottom.

B. Second Crimp

1. Move the flag terminal into position for the second crimp. Refer to Figure 7. Close the tool handles to complete the crimp.
2. Refer to Section 5, CRIMP INSPECTION, to inspect the flag terminal crimp.

5. CRIMP INSPECTION

Inspect crimped terminals and splices by checking the features described in Figures 8 and 9. Use only terminals and splices that meet the conditions described. Damaged product should not be used.

6. MAINTENANCE AND INSPECTION

Hand tools are inspected before shipment. The tool received should be inspected immediately upon arrival to ensure that it has not been damaged during shipment, and that it performs according to the criteria described in this sheet. If the tool is damaged upon arrival, retain the shipping container, file a claim with the carrier, and notify Tyco Electronics immediately.

6.1. Daily Maintenance

1. Remove dust, moisture, and other contaminants from the tool with a clean brush or a soft, lint-free cloth. Do NOT use objects that could damage the tool.
2. Make certain that all pins, pivot points, and bearing surfaces are protected with a THIN coat of any good SAE 20 motor oil. Do NOT oil excessively.
3. When the tool is not in use, keep the handles closed to prevent objects from becoming lodged in the crimping areas and store the tool in a clean, dry area.

CABLE MAKER Battery Terminals

Note: Not to Scale

Straight Terminals

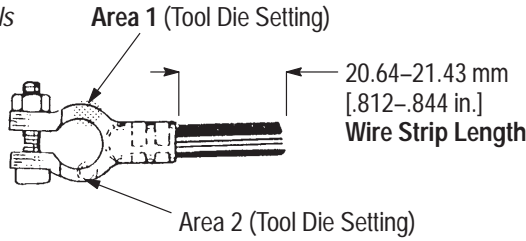

Flag Terminals (Standard Barrel)

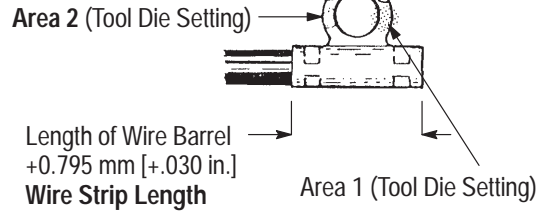

Flag Terminal (Left Hand)

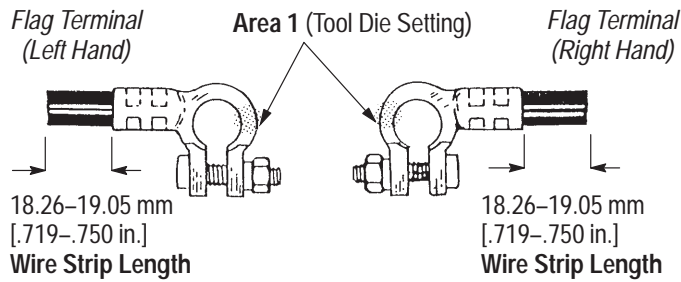

Flag Terminal (Right Hand)

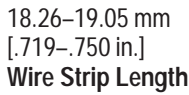

Flag Terminal (Long Barrel)

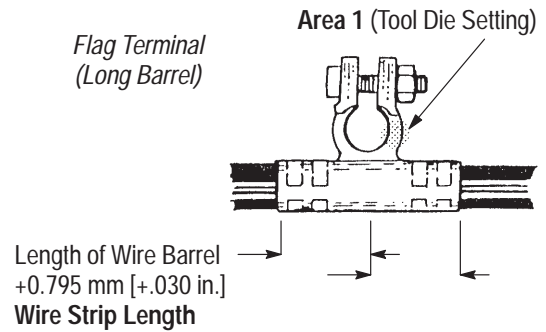

STRAIGHT TERMINAL	FLAG TERMINAL				WIRE DIAMETER RANGE (mm [in.])	TOOL DIE SETTING (See Area 1 on Terminal)
	STANDARD BARREL	LONG BARREL	LEFT HAND	RIGHT HAND		
29251	—	—	—	—	5.562-6.908 [.219-.272]	J-H
29253	—	—	—	—	4.749-5.537 [.187-.218]	K-K
29245-3	—	29717-1	601305-1	601305-2	9.779-10.972 [.385-.432]	E-A
29245-5	—	29717-2	601305-3	601305-4		
29249	—	—	—	—	6.934-8.763 [.273-.345]	H-H
29249-3	—	—	—	—		
29249-5	—	—	—	—		
29243	29705	29716-1	601306-1	601306-2	10.998-12.115 [.433-.477]	A-C
29711	—	29716-2	601306-3	601306-4		
29712	29706	—	—	—		
29702	—	29718-1	—	—	12.141-13.614 [.478-.536]	A-B
29713	—	29718-2	—	—		
29714	—	29709	—	608792-4	13.639-16.383 [.537-.645]	A-A
29715	—	29710	—	608794-4		

Figure 6

CABLE MAKER Battery Terminals

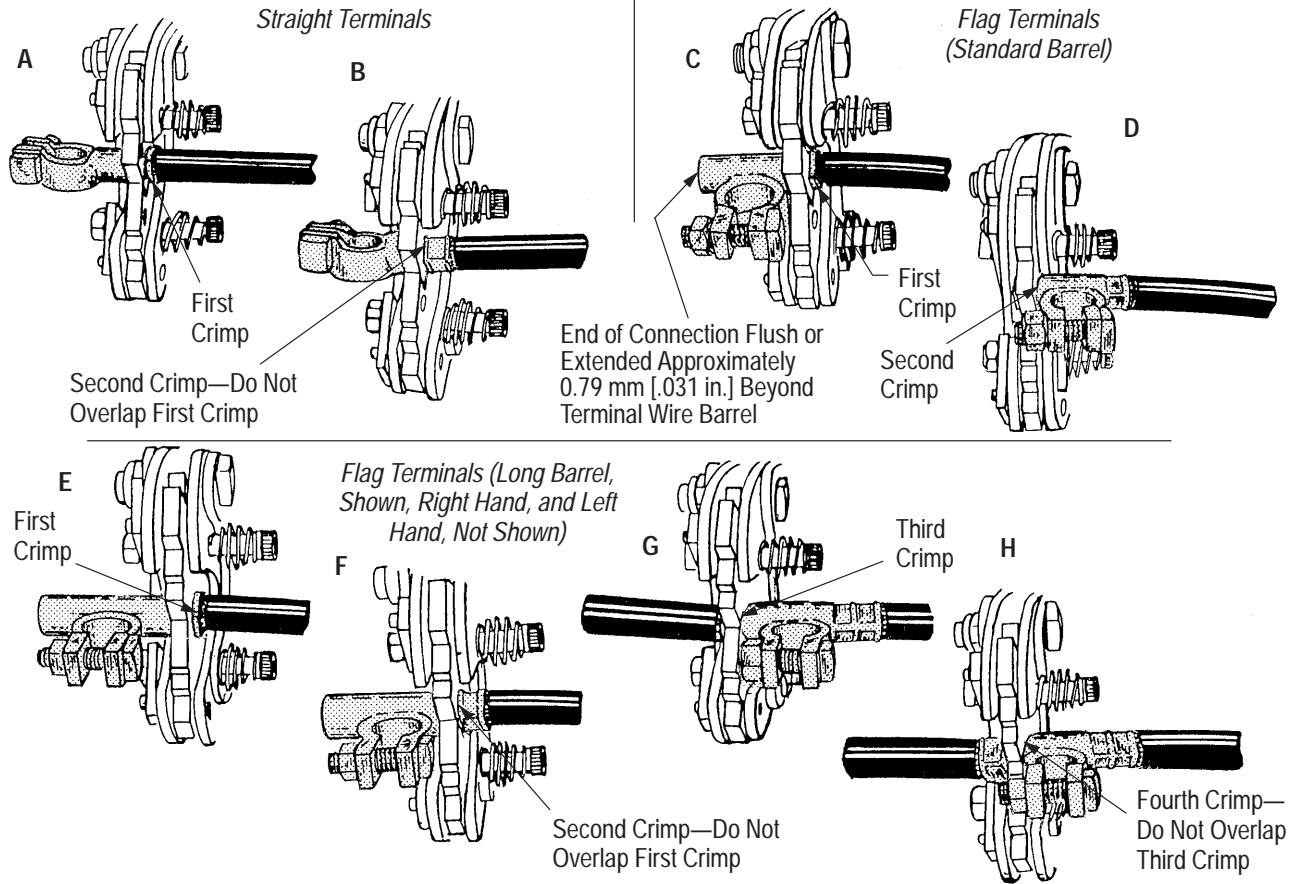

Figure 7

6.2. Periodic Inspection

Regular inspections should be performed by quality control personnel. A record of scheduled inspections should remain with the tool or be supplied to personnel responsible for the tool. Though recommendations call for at least one inspection per month, the inspection frequency should be based on the amount of use, working conditions, operator training and skill, and established company standards. These inspections should be performed in the following sequence:

A. Visual Inspection

1. Remove all lubrication and accumulated film by immersing the tool (handles partially closed) in a suitable commercial degreaser that will not affect paint or plastic material.
2. Make certain that all parts are securely in place. If replacements are necessary, refer to Section 7.
3. Inspect crimping areas for chipped or cracked surfaces.

B. Handle Adjustment Inspection (Figure 10)

The handle adjustment should be checked to ensure that the dies are bottoming fully. The handle adjustment feature is provided to compensate for normal die wear.

To check the handle adjustment:

1. Open the tool handles fully.
2. Rotate the dies into adjustment position (Die Setting E-A).
3. Close the tool handles until the dies are touching, but not under pressure.
4. Measure the distance between the tool handles, as shown in Figure 10. The measurement must be between 34.92 and 41.27 mm [1.375 and 1.625 in.]. If the adjustment does not fall within this range, the adjustment must be tightened or loosened as necessary.

To loosen the adjustment:

- a. Turn both adjustment (ADJ) screws *counterclockwise* approximately one-half to three-quarter turn.

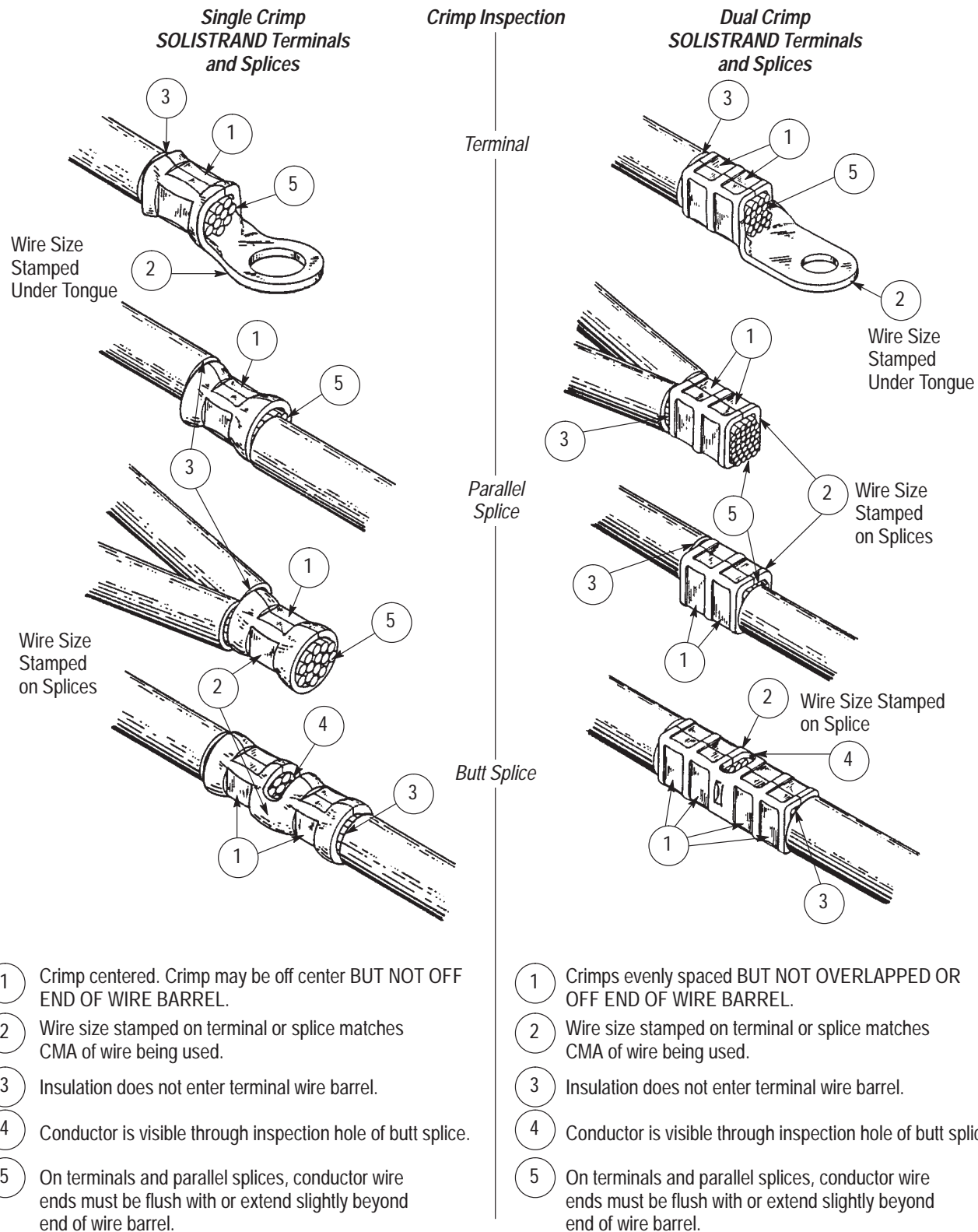
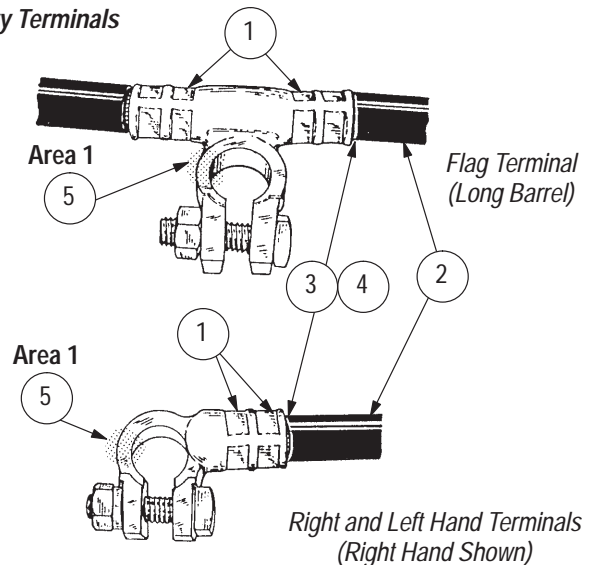
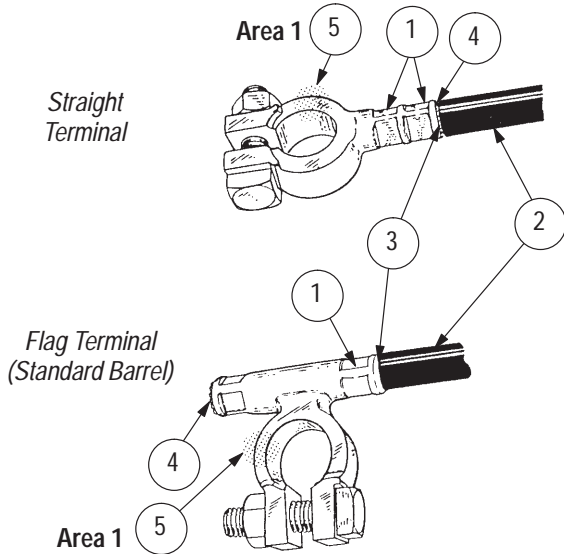

Figure 8

Crimp Inspection

CABLE MAKER Battery Terminals



Flag Terminals (Straight, Long Barrel, Left and Right Hand)

Flag Terminal (Standard Barrel)

- ① Crimps evenly spaced BUT NOT OVERLAPPED OR OFF END OF WIRE BARREL.
- ② Stripped wire insulation diameter is within insulation diameter range of terminal.
- ③ No nicked or missing conductor strands.
- ④ Wire fully inserted.
- ⑤ Selected die setting matches letters displayed in Area 1.

- ① Crimps properly located. Crimps must not be off end of wire barrel.
- ② Stripped wire insulation diameter is within insulation diameter range of terminal.
- ③ No nicked or missing conductor strands.
- ④ End of conductor is flush or extended approximately 0.80 mm [.0313 in.] beyond end of terminal wire barrel.
- ⑤ Selected die setting matches letters displayed in Area 1.

Figure 9

- b. Slightly loosen both lock (LOCK) screws by turning them *counterclockwise*.
- c. Flex the tool by opening and closing the tool handles.
- d. Tighten both lock screws.
- e. Close the tool handles until the dies are touching, but not under pressure. Check the measurement between the tool handles. If necessary, repeat the adjustment procedure.

To tighten the adjustment:

- a. Turn both lock (LOCK) screws *counterclockwise* approximately one-half to three-quarter turn.
- b. Turn both adjustment (ADJ) screws *clockwise* approximately one-half to three-quarter turn.
- c. Flex the tool by opening and closing the tool handles.
- d. Tighten both lock (LOCK) screws.

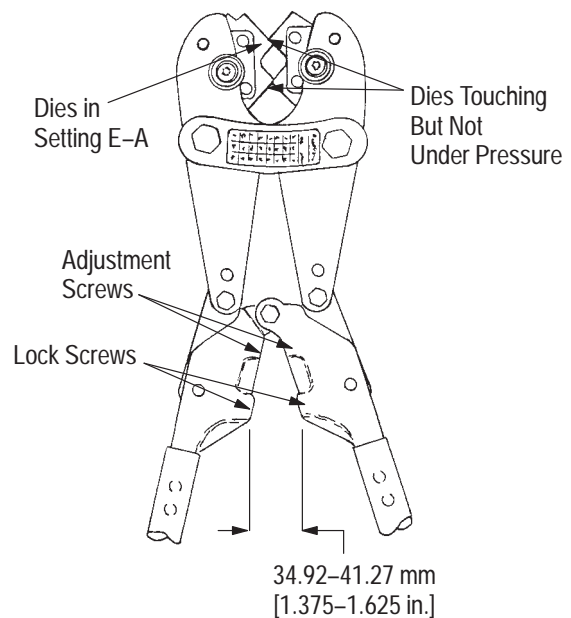

Figure 10

e. Close the tool handles until the dies are touching but not under pressure. Check the measurement between the tool handles and repeat the adjustment procedure if necessary.

C. Crimp Height Inspection (Figure 11)

Crimp height inspections should be performed periodically to determine if the tool is maintaining proper crimping dimensions. To check the crimp height:

1. Perform the handle adjustment inspection as described in Paragraph 6.2, B, Handle Adjustment Inspection. Adjust the handles if necessary.
2. Crimp a properly prepared stranded wire in SOLISTRAND terminal or splice, as previously described.

CAUTION Do not use wires with missing conductor strands.

3. Using a conventional cone-point micrometer, measure the crimp heights at the midpoints of flats "A" and "B," as shown in Figure 11. The SUM of the two measurements equals the crimp height dimension.

NOTE Do not allow the cone point to enter the terminal brazed seam.

4. Figure 11 lists the crimp height dimension (sum of "A" and "B" measurements) range for each wire size. If the measured dimension is within the listed range, the die closure is considered dimensionally correct.
5. If the measured crimp height dimension is not within the specified range (and the tool handles are properly adjusted), refer to Section 7 for information on obtaining customer repair service.

7. REPLACEMENT AND REPAIR

Customer-replaceable parts are listed in Figure 12. A complete inventory should be stocked and controlled to prevent lost time when replacement of parts is necessary. Parts other than those listed should be replaced to ensure quality and reliability. Order replacement parts through your Tyco Electronics Representative, or call 1-800-526-5142, or send a facsimile of your purchase order to 717-986-7605, or write to:

CUSTOMER SERVICE (038-035)
TYCO ELECTRONICS CORPORATION
PO BOX 3608
HARRISBURG PA 17105-3608

For customer repair service, please contact an Tyco Electronics Representative at 1-800-526-5136.

Crimp Height Measurements
(Tool Handles Properly Adjusted, See Paragraph 6.2, B)

"A" + "B" = Crimp Height Dimension

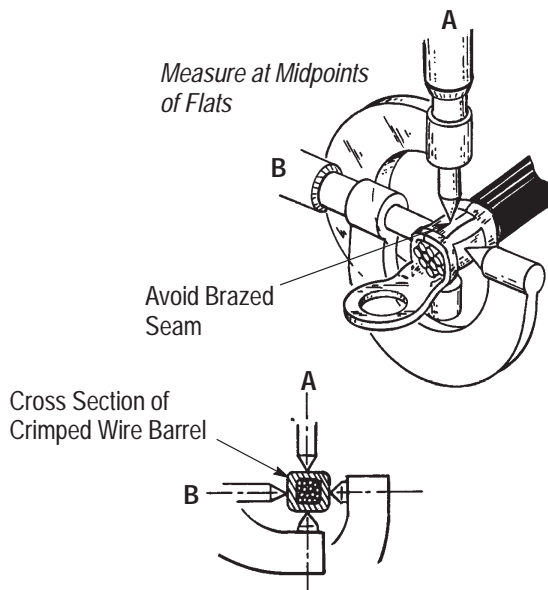

WIRE SIZE (AWG)	CRIMP HEIGHT DIMENSION RANGE (mm [in.])
8	10.464-11.049 [.412-.435]
6	13.004-13.589 [.512-.535]
4	16.230-16.916 [.639-.666]
2	19.405-20.142 [.764-.793]
1/0	22.631-23.418 [.891-.922]
2/0	25.146-26.111 [.990-1.028]
3/0	28.854-30.022 [1.136-1.182]
4/0	32.562-33.833 [1.282-1.332]

Figure 11

8. REVISION SUMMARY

Revisions to this instruction sheet per EC 0990-0913-03 include:

- Updated document to corporate requirements
- Deleted the word "INSULATION" from table column in Figure 6
- Corrected part number in Figure 6
- Corrected Figure 7 reference in Paragraph 4.4.A.1

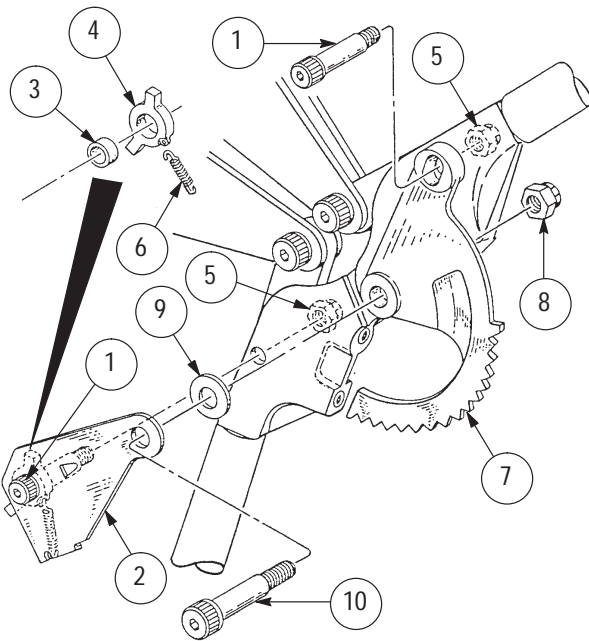
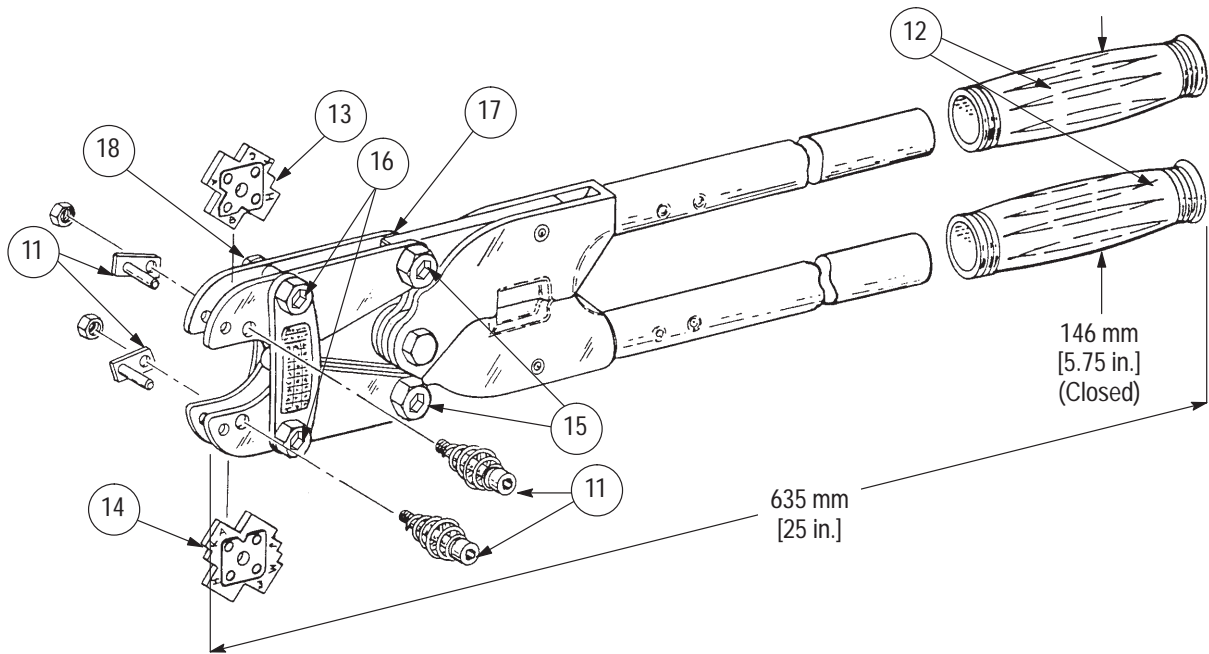

Note: CERTI-CRIMP* Ratchet Assembly 604220-1 (Items 1 through 10) is used on Tool 600850-1 only.

ITEM	PART NUMBER	DESCRIPTION	QTY PER TOOL
1	1-21004-2	SCREW, Shoulder, .312 in. Dia	2
2	604222-1	GUARD	1
3	604224-1	BUSHING	1
4	604223-1	PAWL	1
5	21021-5	NUT, .25 in.	2
6	986816-2	SPRING	1
7	604228-1	RACK	1
8	21021-6	NUT, .312 in.	1
9	604229-1	WASHER, Anti-Friction	1
10	2-21004-1	SCREW, Shoulder, .38 in. Dia	1
11	600852	ASSEMBLY, Die Indexing Pin	2
12	604274-1	GRIP, Handle	2
13	600881	DIE, Right	1
14	600880	DIE, Left	1
15	2-21004-0	BOLT, Shoulder	2
16	600862-2	BOLT, Shoulder	2
17	21021-6	NUT	2
18	21021-7	NUT	2

Figure 12

Mouser Electronics

Authorized Distributor

Click to View Pricing, Inventory, Delivery & Lifecycle Information:

[TE Connectivity:](#)

[600852](#)