

1. INTRODUCTION

This application specification covers the requirements for the application of CHAMP* Latch low-profile connectors to ribbon cable. It will also provide the panel cutout dimensions, strain relief hardware and a visual examination for terminated connectors.

NOTE All dimensions presented, unless otherwise indicated, are in inches.

2. REFERENCE DOCUMENTS

- 2.1. For connector selection, cable requirements, and accessories, refer to AMP Instruction Sheet IS 3158 and Catalog 73-152.
- 2.2. For hand tool termination procedures, refer to IS 3135, and for arbor frame assembly termination procedures, refer to IS 3134.

3. NOMENCLATURE

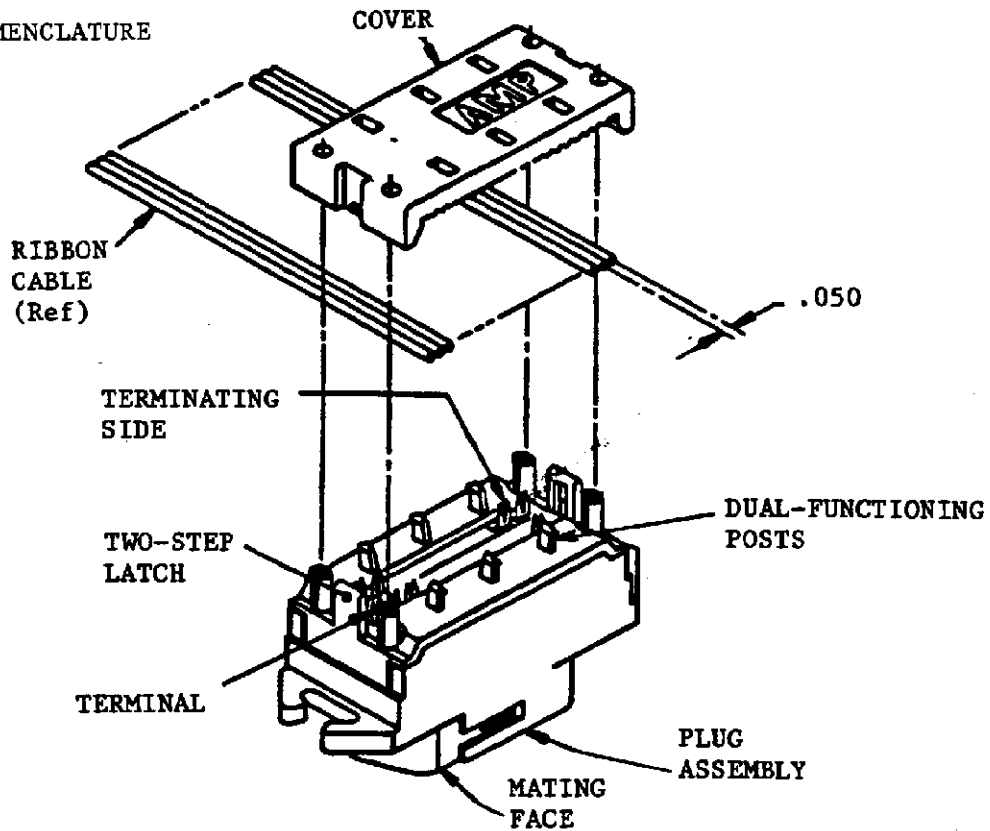

Fig. 1 Connector Nomenclature

*TRADEMARK OF AMP INCORPORATED

© COPYRIGHT 1986
 BY AMP INCORPORATED HARRISBURG, PA. ALL INTERNATIONAL
 RIGHTS RESERVED. AMP PRODUCTS MAY BE COVERED BY U.S. AND
 FOREIGN PATENTS AND/OR PATENTS PENDING

				APPLICATION SPECIFICATION		AMP AMP INCORPORATED Harrisburg, Pa. 17105	
				ENGINEERING APPROVAL & DATE Steve Hege 5/13/86		NO. 114-6030	
				SHEET 1 OF 5		TITLE CHAMP LATCH LOW-PROFILE CONNECTORS	
LTR.	REVISION RECORD	APP.	DATE				

4. REQUIREMENTS

4.1. Mounting Requirements

Panel mount connectors (unshielded and loose piece shielded) can be front or back panel mounted. Refer to Figure 2 for panel thickness and cutout dimensions.

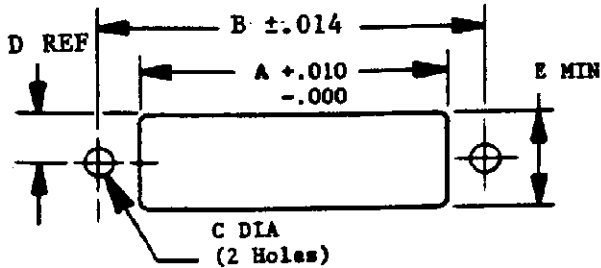

PANEL CUT OUT FOR UNSHIELDED AND LOOSE PIECE SHIELDED

NO. OF POSN	FRONT PANEL MOUNT *					REAR PANEL MOUNT **				
	A	B	C	D	E	A	B	C	D	E
14	1.063	1.416	.126	.320	.640	1.151	1.416	.149	.310	.620
24	1.488	1.842	.126	.320	.640	1.575	1.842	.149	.310	.620
36	2.000	2.352	.126	.320	.640	2.085	2.352	.149	.310	.620
50	2.700	2.946	.126	.320	.640	2.700	2.946	.149	.310	.620

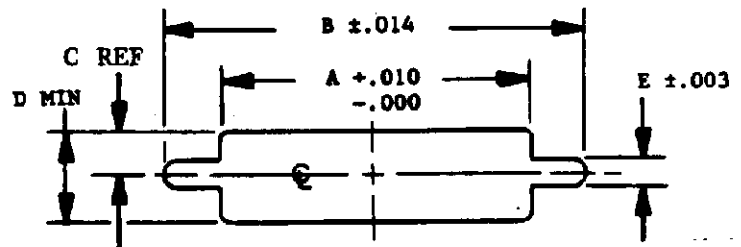

PANEL CUT OUT FOR IEEE-488 METRIC/PRE-ASSEMBLED PRODUCT

NO. OF POSN	FRONT PANEL MOUNT *					REAR PANEL MOUNT				
	A	B	C	D	E	A	B	C	D	E
24 IEEE-488 Metric	1.488	2.036	.320	.640	.192	1.575	2.036	.310	.620	.192
24 Pre-Assy	6-32 UNC-2B Screw Lock					1.575	1.994	.310	.620	.152 +
	4-40 UNC-2B Screw Lock					1.575	1.968	.310	.620	.126
	6-32 UNC-2B Bail Lock					1.806	1.994	.310	.620	.152
36 Pre-Assy	4-40 UNC-2B Bail Lock***					1.806	1.968	.310	.620	.126
	6-32 UNC-2B Screw Lock					2.085	2.504	.310	.620	.152
	4-40 UNC-2B Screw Lock					2.085	2.478	.310	.620	.126
50 Pre-Assy	6-32 UNC-2B Bail Lock					2.316	2.504	.310	.620	.152
	4-40 UNC-2B Bail Lock***					2.316	2.478	.310	.620	.126
	6-32 UNC-2B Screw Lock					2.700	3.098	.310	.620	.152
50 Pre-Assy	4-40 UNC-2B Screw Lock					2.700	3.072	.310	.620	.126
	6-32 UNC-2B Bail Lock					2.910	3.098	.310	.620	.152
	4-40 UNC-2B Bail Lock***					2.910	3.072	.310	.620	.126

Front panel mount panel thickness range .062-.125 in.

Rear panel mount panel thickness range .062 Max.(Std, except for ***), .062-.093 (metric).

* For front panel mount applications, it is recommended that cable assembly be fed from the front of the panel to avoid excessive bending of the cable which would occur if fed from the rear of the panel. Loose piece shielded (EMI) product can be front or rear panel mounted, while the pre-assembled shielded (EMI) product can only be rear panel mounted.

** Screw lock version only.

*** Panel thickness may be .093 Maximum for bail lock applications with 4-40 screws, but clearance between the incoming mating connector and bail clips on pre-assembled parts is minimal.

+ For Metric application of pre-assembled product use rear panel mount dimension given for IEEE-488 Metric in Table.

Fig. 2 Mounting Specifics

AMP

AMP INCORPORATED
Harrisburg, Pa. 17105

PAGE

NO.

2

114-6030

4.2. Additional Strain Relief Requirements

If the terminated connectors (cable-to-cable) are going to be used in an area where an extreme amount of axial pull or 90° pull will be present, the addition of strain relief 554099-1 is recommended, see Figure 3. At present only the 50-position strain relief is available, but other positions can be produced if required.

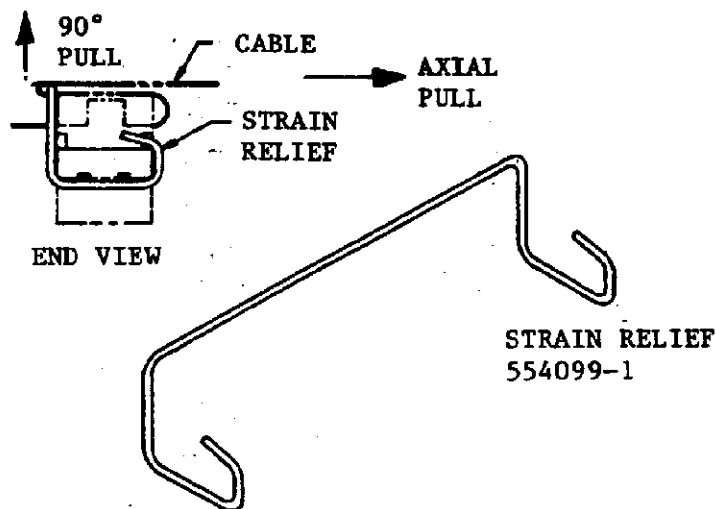
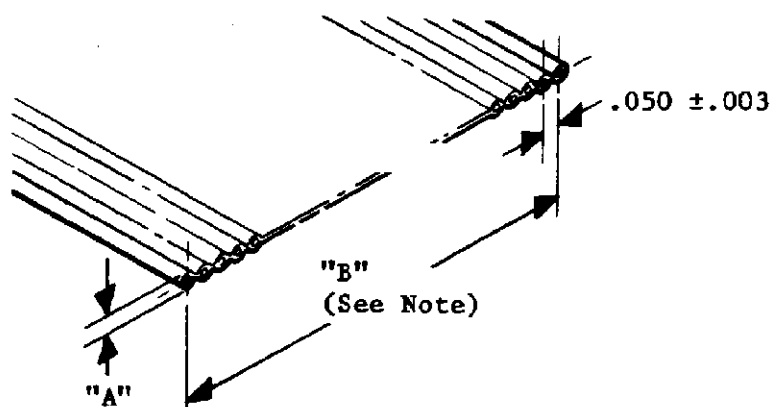

Fig. 3 Strain Relief

4.3. Special Cable Preparation Requirements

A. Cable Types

These connectors are designed to terminate ribbon cable with solid or stranded round conductors on .050-in. centerlines. Refer to Figure 4 for the recommended cable dimensions.



NOTE: ACCUMULATIVE TOLERANCE FOR CABLE CONDUCTORS
1 THROUGH 36 IS + .010 AND THROUGH 50 IS + .015

CONDUCTOR		DIMENSION	
SIZE	TYPE	"A"	"B"
26	Solid	.032/.045	14 Posn 0.650
28	Stranded or Solid		24 Posn 1.150
			36 Posn 1.750
30	Solid		50 Posn 2.450

Fig. 4 Cable Type

AMP

AMP INCORPORATED
Harrisburg, Pa. 17105

PAGE NO.

3

114-6030

B. Cable Insulation

The connector has been tested and found to be compatible with a wide variety of cable insulations including: extruded, coextruded, single laminated, and double laminated. However, due to the many variations in cable construction and insulating material hardness, it is recommended that sample terminations be made on the proposed cable to assure compatibility with the connector. If problems are encountered, please forward a cable sample to AMP Product Engineering for further evaluation.

C. Cable Storage

Proper storage of the cable is important to prevent distortion of the centerline dimension which could cause terminal registration problems. The cable should be stored with the "flat" side supported. Reels must be stored in an upright position (standing on edge), or they must be supported on an axle.

D. Cable Preparation

The cable should be cut straight and perpendicular to the conductors. Do NOT tear or cut the cable with scissors, razor blades, or paper cutters which can pull strands of wire across the cut face of the cable and cause shorts. Use AMP Cable Cutter 91220-1 and refer to IS 6574 for proper procedures. See Figure 5.

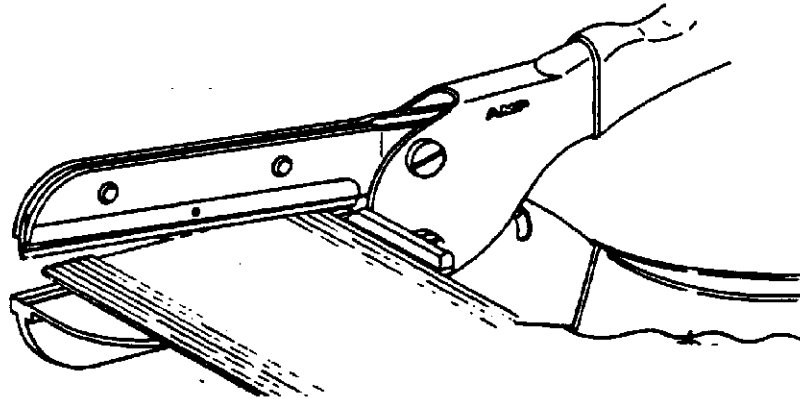

Fig. 5 Cable Cutter

4.4. Visual Examination

A. Cover Closure

To verify that the connectors have been fully terminated, make sure the strain relief latches are securely fastened and there is no gap between the housing assembly and cover.

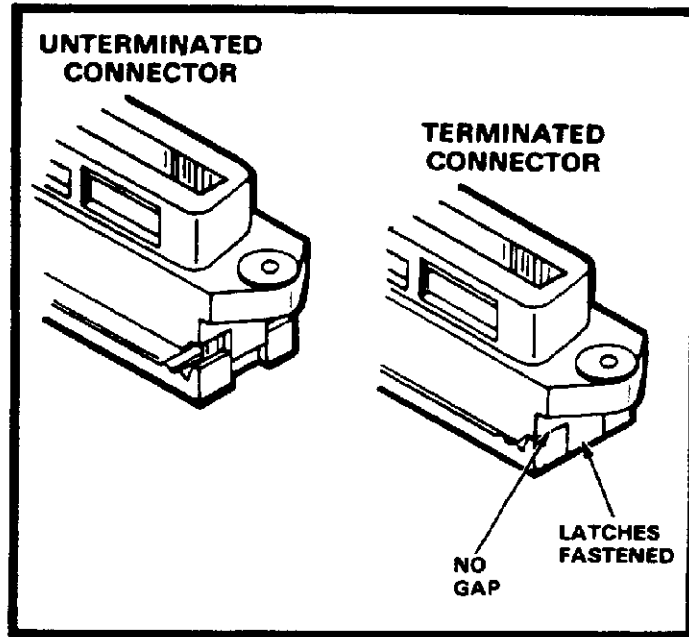

Fig. 6. Cover Closure

B. End-Of-Line

For end-of-line connections, possible shorting problems could result from wires not within the connector envelope on the dead-end side, keep the wires flush.

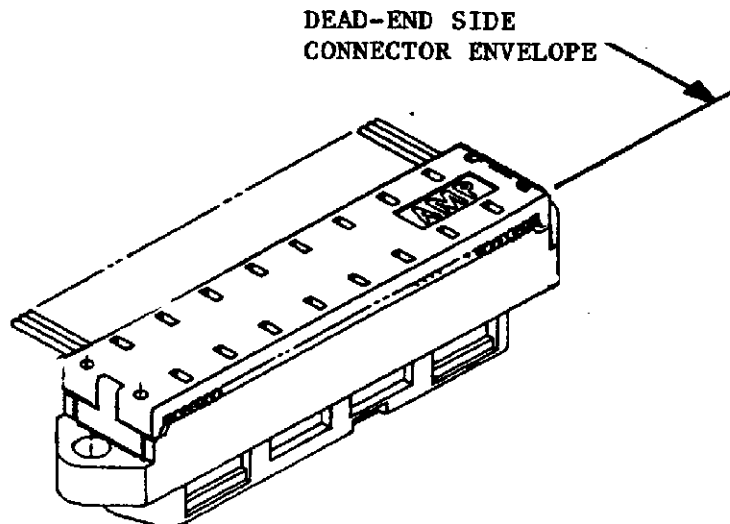

Fig. 7 End-of-Line Application

Mouser Electronics

Authorized Distributor

Click to View Pricing, Inventory, Delivery & Lifecycle Information:

[TE Connectivity:](#)

[552933-1](#)