

PART NUMBER	REVISION	DESCRIPTION	FEED TYPE
2150639-1	C	FINE CRIMP HEIGHT ADJUST	MECHANICAL
2150639-2	C	FINE CRIMP HEIGHT ADJUST	PNEUMATIC
7-2150639-1	C	MECHANICAL AND CRIMP TOOLING KIT	MECHANICAL
7-2150639-2	C	PNEUMATIC AND CRIMP TOOLING KIT	PNEUMATIC
7-2150639-7	B	CRIMP TOOLING KIT	-

ATLANTIC VERSION TERMINATOR INTERFACE ADAPTER

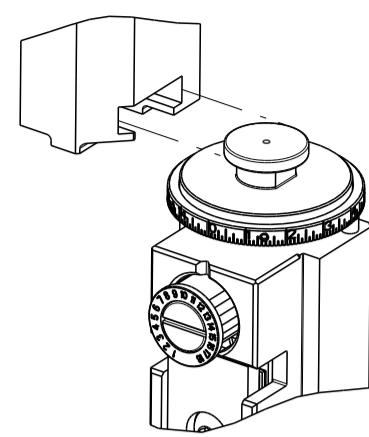

APPLICATOR DATA		
CRIMP	SIZE	TYPE
WIRE	4.57 mm [.180]	F
INSUL	6.35 mm [.250]	F
APPL INSTRUCTIONS 408-35043		

TERMINAL DATA: TE TERMINAL TE CRIMP SPECIFICATION			
TERMINAL NAME: RING TOUGUE			
WIRE STRIP LENGTH	INSULATION DIAMETER RANGE		
5.80-6.60 mm [.228-.260 IN]	∅3.18-5.33 mm [.125-.210 IN]		
TERMINAL APPLICATION SPECIFICATION	114-3118		
TERMINALS APPLIED			
TE TERMINAL	TE TERMINAL	TE TERMINAL	TE TERMINAL
626036-1	626036-2	626036-3	

WIRE SIZE	CRIMP HEIGHT mm [INCH]	CRIMP HEIGHT REFERENCE SETTING
6.00mm2	3.61+/-0.05 [.142+/- .002]	5.0
5.00mm2	3.43+/-0.05 [.135+/- .002]	7.2
4.00mm2	3.25+/-0.05 [.128+/- .002]	9.0

- RECOMMENDED SPARE PARTS
- REFER TO SUPPLIED INSTRUCTION SHEET FOR CLEANING, LUBRICATION AND STORAGE OF APPLICATOR.
- APPLY PART NUMBER 2-23419-6 LOCTITE TO THREADS OF ITEM 242.
- CRIMP HEIGHT REFERENCE SETTING WAS THE SETTING USED WHEN THE APPLICATOR WAS QUALIFIED AT THE FACTORY. ADJUSTMENT MAY BE NECESSARY WHEN RUNNING APPLICATOR IN THE FIELD.
- UNLESS SPECIFIED OTHERWISE TORQUE VALUES SHALL BE USED PER DOCUMENT, 101-35000.

***WARNING**
ON INSTALLATION, SET WIRE DISC TO CRIMP HEIGHT REFERENCE SETTING FOR LARGEST WIRE SIZE. CRIMP HEIGHT REFERENCE SETTINGS GREATER THAN THE VALUE SHOWN MAY CAUSE DAMAGE TO THE CRIMP TOOLING. REFER TO THE INSTRUCTION SHEET FOR PROPER SETUP AND ADJUSTMENTS.

ATLANTIC VERSION
Shown on sheets 1 of 4 & 2 of 4
(Pacific version shown on sheets 3 of 4 & 4 of 4)

LOC	DIST	REVISIONS					
A	66	P	LTN	DESCRIPTION	DATE	OWN	APVD
		1		DEVELOPMENT	06FEB2016	XZ	UG
		A		RELEASED	15MAR2016	BH	BH
		B		ECR-18-000685	16JAN2018	JAH	CT
		C		ECR-18-015353	27SEP2018	TB	TE

-	1	-	1	-	2119640-1	PUSH ROD, AIR FEED	250	
-	1	-	1	-	1803259-1	BUSHING, FLANGED	249	
-	1	-	1	-	2119641-1	FEED CAM, AIR FEED	248	
-	1	1	1	1	2119082-7	CAM, SNAIL, INSULATION ADJUSTMENT	244	
-	1	1	1	1	2079764-1	WASHER, WAVE SPRING, CREST-TO-CREST	243	
-	1	1	1	1	2119083-1	RETAINER, INSULATION DIAL	242	
-	-	1	-	1	2119580-1	MECHANICAL FEED ASSEMBLY	239	
-	1	-	1	-	2063440-1	AIR FEED MODULE	238	
-	1	1	1	1	1-18028-0	WASHER, FLAT, REG M8	192	
-	2	-	2	-	21045-3	RING, RETAIN, EXTERN, 3/16 CRESCENT	172	
-	REF	REF	REF	REF	994970-2	COUNTER, MAGNETIC	164	
-	1	-	1	-	240638-1	SPRING, FEED FINGER	163	
-	1	-	1	-	3-23627-7	PIN, RETAIN, GRVD, 3/16 X .854	137	
-	1	1	1	1	455888-4	SPACER, CRIMPER	82	
-	1	1	1	1	2119791-5	DEPRESSOR, WIRE	73	
-	1	1	1	1	1803607-2	DOCUMENTATION PACKAGE	71	
-	2	2	2	2	2-18032-2	SCR, SET, FLT PNT, M3 X 10.0	70	
-	1	1	1	1	2119943-1	WASHER, SPACER	69	
-	1	1	1	1	2119740-1	TAG, IDENTIFICATION	67	
-	2	2	2	2	2168078-1	SCREW, DRIVE, RH, RoHS, 2 x .188	66	
-	1	1	1	1	2168083-2	SCR, SKT HD CAP, RoHS, M4 X 8.0	60	
-	-	1	-	1	5-18022-5	SCR, HEX HD CAP, M4 X 6.0	59	
-	-	1	-	1	2063961-1	FEED FINGER	58	
-	4	4	4	4	2168400-4	SHCS, LOW HEAD, RoHS, M4 X 8	57	
-	2	2	2	2	1-2168083-0	SCR, SKT HD CAP, RoHS, M4 X 10	56	
-	2	2	2	2	5018030-1	NUT, HEX, REG, RoHS, M3	54	
-	2	2	2	2	986965-8	NUT, LOCK, HEX, TORQUE (M4)	53	
-	1	-	1	-	2119792-2	PAWL, EF, AIR	51	
-	1	2	1	2	18023-9	SCR, SKT HD CAP M4 X 6.0	49	
-	-	1	-	1	2119652-1	FEED CAM, PRE FEED	48	
-	-	1	-	1	2119653-1	FEED CAM, POST FEED	47	
-	1	1	1	1	2119655-5	APPLICATOR BASIC ASSEMBLY, EF	46	
-	1	1	1	1	1803517-1	RAM ASSEMBLY, EF ATLANTIC	44	
-	1	1	1	1	1803602-1	SCR, BHSC, RoHS (M8 X 25)	41	
-	8	8	8	8	1-18028-2	WASHER, FLAT, REG M4	33	
-	2	2	2	2	2168083-9	SCR, SKT HD CAP, RoHS, M4 X 20	31	
-	2	2	2	2	2168083-2	SCR, SKT HD CAP, RoHS, M4 X 8.0	29	
-	1	1	1	1	690455-1	STRIPPER, FRONT CASTING	27	
-	2	2	2	2	1-2168083-5	SCR, SKT HD CAP, RoHS, M4 X 30	25	
-	1	1	1	1	1752371-1	PLATE, STRIP GUIDE	24	
-	2	2	2	2	2-22281-3	SPRING, COMPRESSION	22	
-	1	1	1	1	1803292-4	DRAG	20	
-	1	1	1	1	1901696-4	STRIP GUIDE, REAR	19	
-	1	1	1	1	1901695-4	STRIP GUIDE, FRONT	18	
-	4	4	4	4	1-2079383-1	SCR, BHSC, RoHS (M6 X 12)	17	
-	1	1	1	1	1-240641-1	SPACER	16	
-	1	1	1	1	240644-1	PLATE, REAR SHEAR	11	
-	-	-	-	-	-	-	10	
-	1	1	1	1	690482-5	PLATE, FRONT SHEAR	9	
1	2	2	1	1	3-1803059-9	ANVIL, COMBINATION, END FEED	8	
-	1	1	1	1	2217206-7	BLADE, SLUG	7	
-	-	-	-	-	-	-	6	
-	1	1	1	1	240641-8	SPACER	5	
-	1	1	1	1	238011-2	BLOCK, CRIMPER SPACER	4	
1	2	2	1	1	2-1633961-5	CRIMPER, INSULATION F PREMIUM	3	
-	1	1	1	1	455888-9	SPACER, CRIMPER	2	
1	2	2	1	1	456412-7	CRIMPER, WIRE .180 F PREMIUM	1	
-	77	72	71	2	-1	PART NO	DESCRIPTION	ITEM NO

DIMENSIONS:		TOLERANCES UNLESS OTHERWISE SPECIFIED:		MATERIAL:		FINISH:		WEIGHT:		SCALE:		SHEET:		REV:	
mm	0 PLC	±													
	1 PLC	±													
	2 PLC	±													
	3 PLC	±													
	4 PLC	±													
	ANGLES	±													
	FINISH	±													

LOC		DIST		REVISIONS			
A	66	P	LTM	DESCRIPTION	DATE	OWN	APVD
		-		SEE SHEET 1			

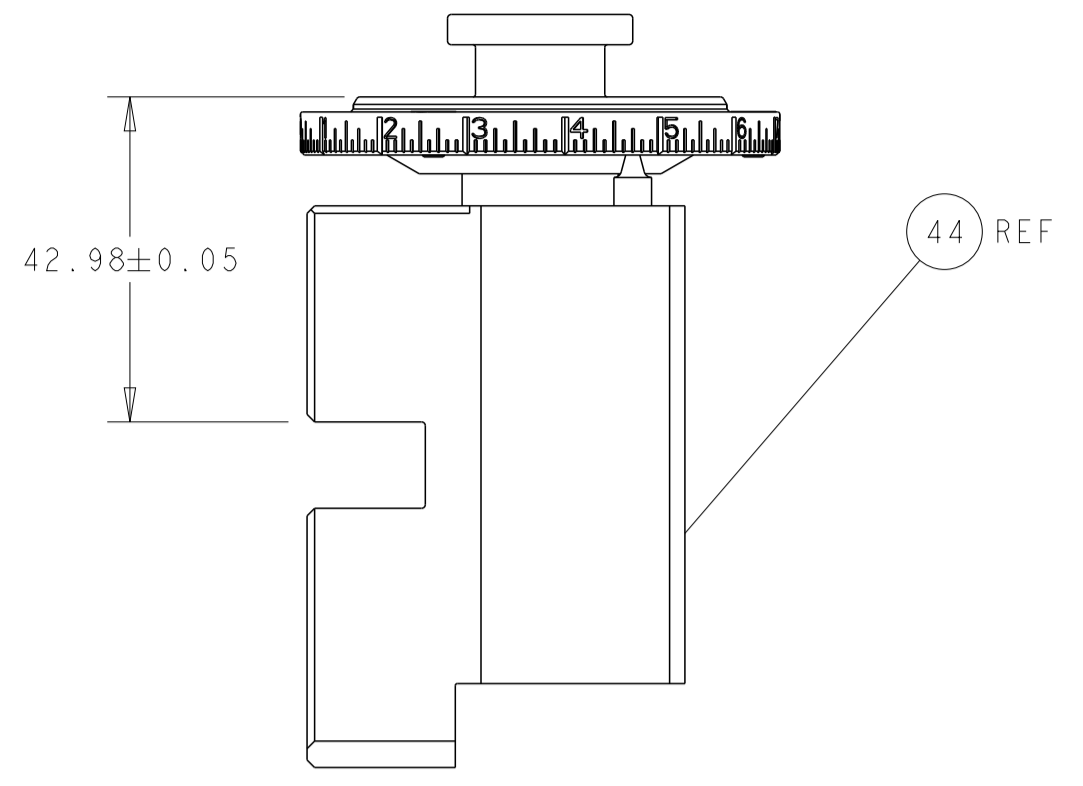

RAM SET-UP

FEED TYPE
MECHANICAL

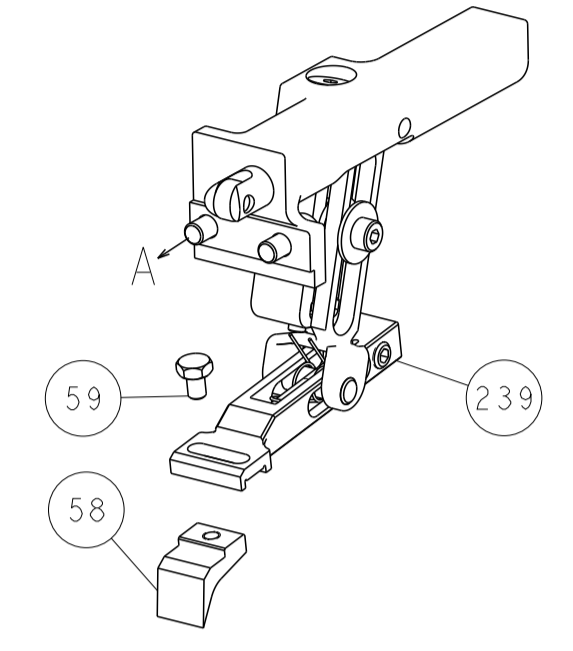

PNEUMATIC

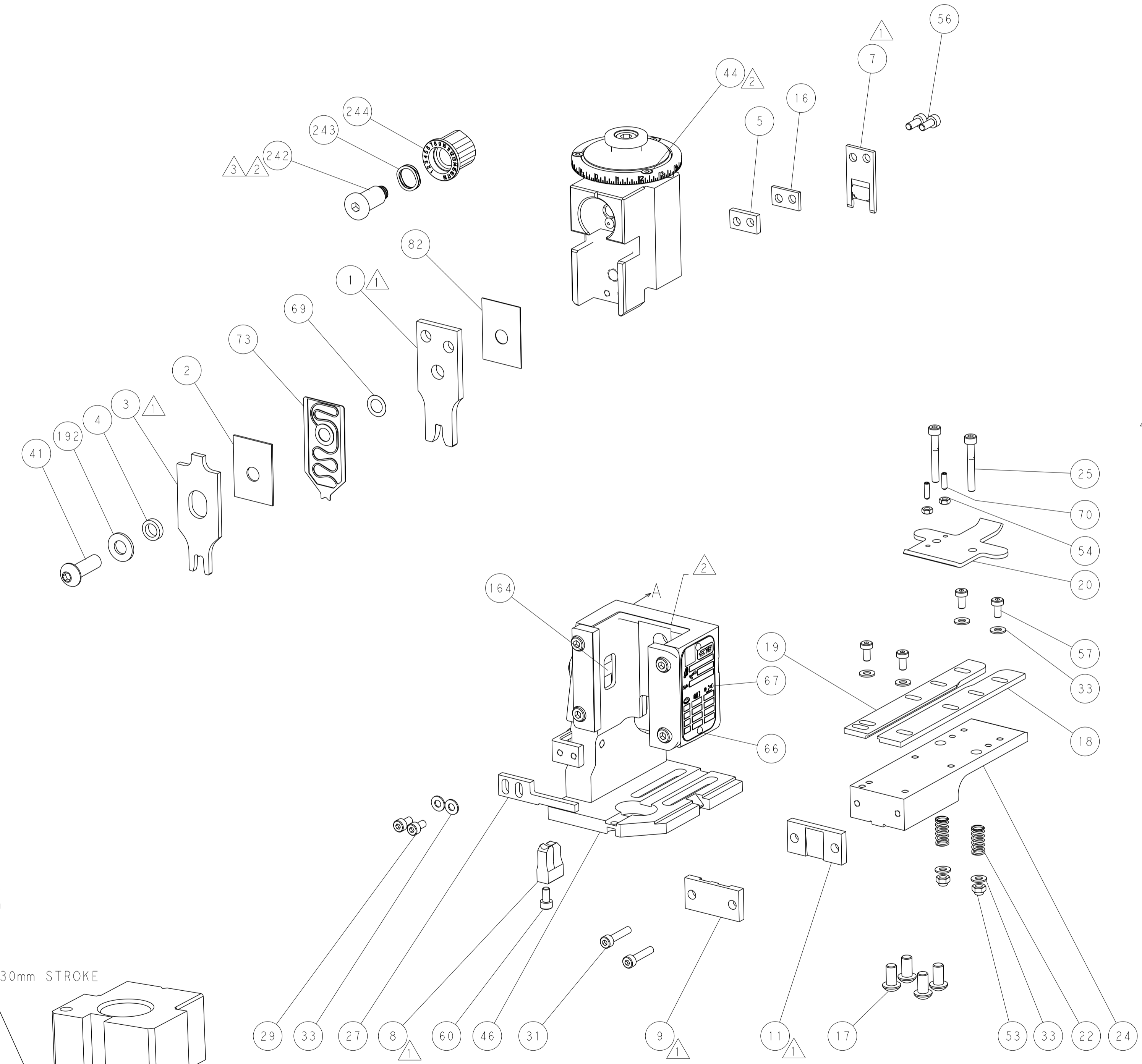
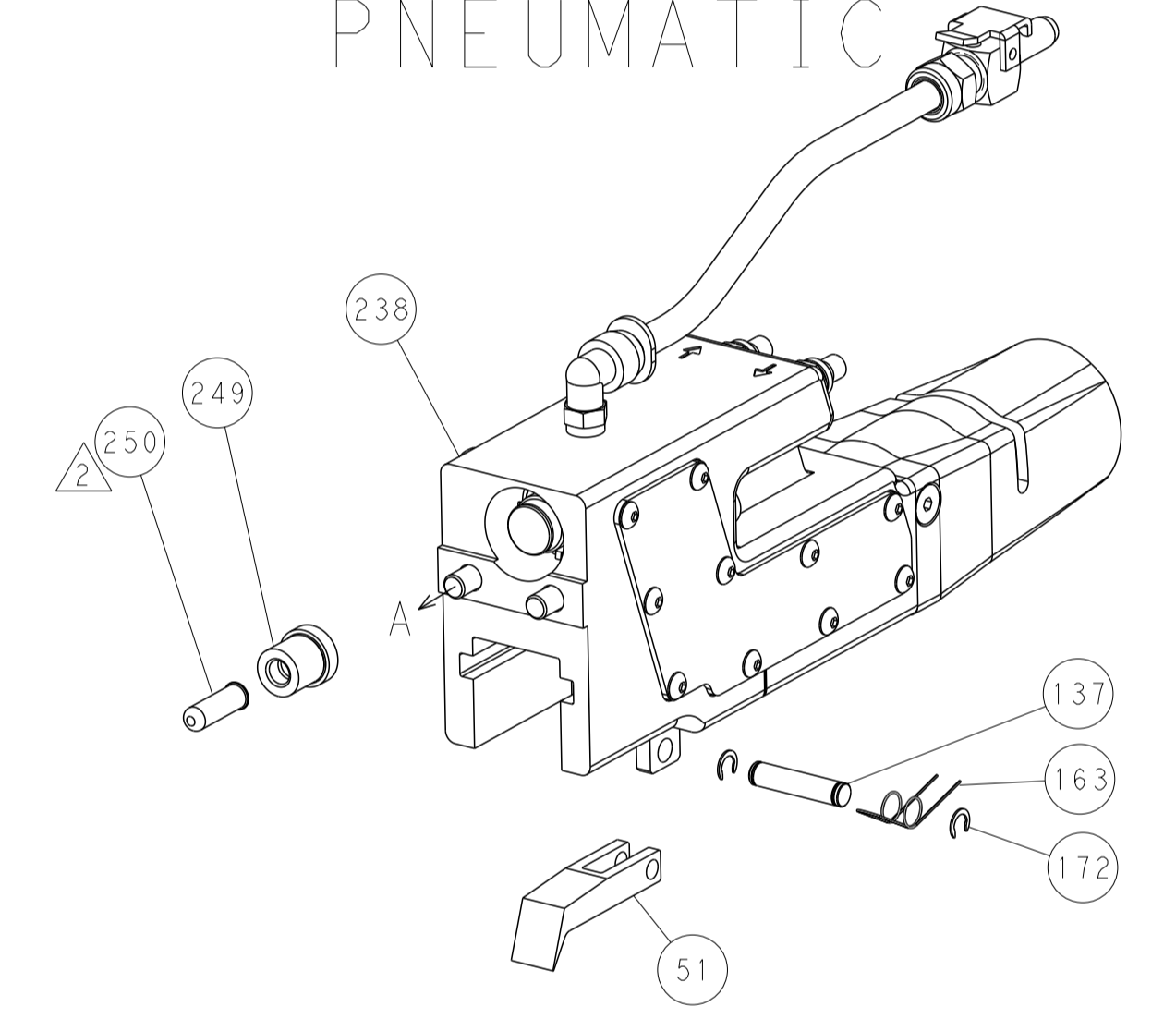

CAM POSITIONS

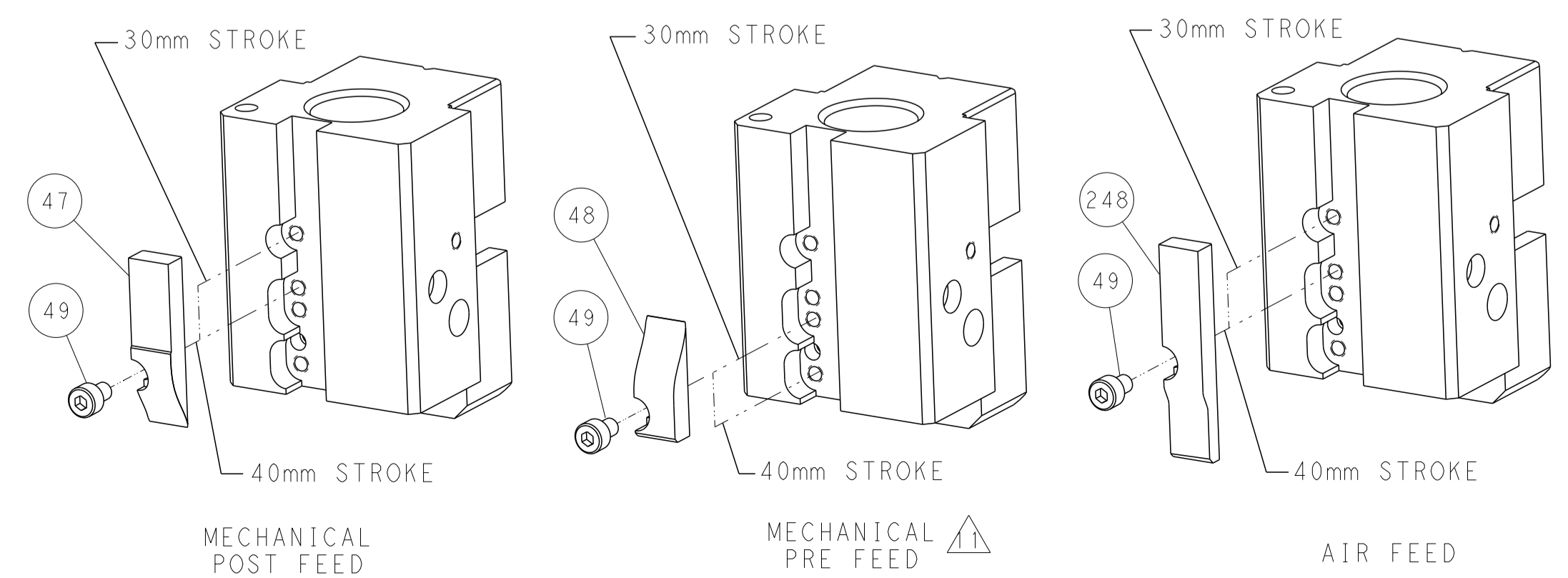

ATLANTIC VERSION
 Shown on sheets 1 of 4 & 2 of 4
 (Pacific version shown on sheets 3 of 4 & 4 of 4)

DIMENSIONS: mm 		TOLERANCES UNLESS OTHERWISE SPECIFIED: 0 PLC ± 1 PLC ± 2 PLC ± 3 PLC ± 4 PLC ± ANGLES ± FINISH		DWN X.ZHAO 06FEB2016 CHK L.ZHANG 06FEB2016 APVD JJ.GUO 06FEB2016		NAME Ocean End Feed Applicator	
MATERIAL:		WEIGHT:		SIZE: A1 CAGE CODE: 00779 DRAWING NO: C-2150639		RESTRICTED TO:	
Customer Accessible Production Drawing				SCALE: 1:1		SHEET 2 OF 4 REV C	

PART NUMBER	REVISION	DESCRIPTION	FEED TYPE
2-2150639-1	C	FINE CRIMP HEIGHT ADJUST	MECHANICAL
2-2150639-2	C	FINE CRIMP HEIGHT ADJUST	PNEUMATIC
7-2150639-7	B	CRIMP TOOLING KIT	-

PACIFIC VERSION TERMINATOR
INTERFACE ADAPTER



APPLICATOR DATA		
CRIMP	SIZE	TYPE
WIRE	4.57 mm [.180]	F
INSUL	6.35 mm [.250]	F
APPL INSTRUCTIONS 408-35043		

TERMINAL DATA: TE TERMINAL		TE CRIMP SPECIFICATION	
TERMINAL NAME: RING TOUGUE			
WIRE STRIP LENGTH		INSULATION DIAMETER RANGE	
5.80-6.60 mm [.228-.260 IN]		∅3.18-5.33 mm [.125-.210 IN]	
TERMINAL APPLICATION SPECIFICATION	114-3118		
TERMINALS APPLIED			
TE TERMINAL	TE TERMINAL	TE TERMINAL	TE TERMINAL
626036-1	626036-2	626036-3	

WIRE SIZE	CRIMP HEIGHT mm [INCH]	CRIMP HEIGHT REFERENCE SETTING
6.00mm2	3.61 +/- 0.05 [.142 +/- .002]	5.0
5.00mm2	3.43 +/- 0.05 [.135 +/- .002]	7.2
4.00mm2	3.25 +/- 0.05 [.128 +/- .002]	9.0

- RECOMMENDED SPARE PARTS
- REFER TO SUPPLIED INSTRUCTION SHEET FOR CLEANING, LUBRICATION AND STORAGE OF APPLICATOR.
- APPLY PART NUMBER 2-23419-6 LOCTITE TO THREADS OF ITEM 242.
- CRIMP HEIGHT REFERENCE SETTING WAS THE SETTING USED WHEN THE APPLICATOR WAS QUALIFIED AT THE FACTORY. ADJUSTMENT MAY BE NECESSARY WHEN RUNNING APPLICATOR IN THE FIELD.
- 5. UNLESS SPECIFIED OTHERWISE TORQUE VALUES SHALL BE USED PER DOCUMENT, 101-35000.

***WARNING**
ON INSTALLATION, SET WIRE DISC TO CRIMP HEIGHT REFERENCE SETTING FOR LARGEST WIRE SIZE. CRIMP HEIGHT REFERENCE SETTINGS GREATER THAN THE VALUE SHOWN MAY CAUSE DAMAGE TO THE CRIMP TOOLING. REFER TO THE INSTRUCTION SHEET FOR PROPER SETUP AND ADJUSTMENTS.

LOC	DIST	REVISIONS					
A	66	P	LTN	DESCRIPTION	DATE	OWN	APVD
-	-	-	-	SEE SHEET 1	-	-	-

-	1	1	2119640-1	PUSH ROD, AIR FEED	250	
-	1	1	1803259-1	BUSHING, FLANGED	249	
-	1	1	2119082-7	CAM, SNAIL, INSULATION ADJUSTMENT	244	
-	1	1	2079764-1	WASHER, WAVE SPRING, CREST-TO-CREST	243	
3	-	1	2119083-1	RETAINER, INSULATION DIAL	242	
-	-	1	2119580-1	MECHANICAL FEED ASSEMBLY	239	
-	1	-	2063440-1	AIR FEED MODULE	238	
-	1	1	1-18028-0	WASHER, FLAT, REG M8	192	
-	4	4	2079383-9	SCR, BHSC, RoHS (M6 X 20)	186	
-	2	2	21045-3	RING, RETAIN, EXTERN, 3/16 CRESCENT	172	
-	REF	REF	994970-2	COUNTER, MAGNETIC	164	
-	1	1	240638-1	SPRING, FEED FINGER	163	
-	1	-	2119641-2	FEED CAM, AIR FEED	152	
-	1	1	2168083-8	SCR, SKT HD CAP, RoHS, M4 X 16	144	
-	-	1	2119653-2	FEED CAM, POST FEED	142	
-	1	1	2119655-6	APPLICATOR BASIC ASSEMBLY, EF	141	
-	1	1	1803518-1	RAM ASSEMBLY, EF PACIFIC	140	
-	1	1	3-23627-7	PIN, RETAIN, GRVD, 3/16 X .854	137	
-	1	1	455888-4	SPACER, CRIMPER	82	
-	1	1	2119791-5	DEPRESSOR, WIRE	73	
-	1	1	1803607-2	DOCUMENTATION PACKAGE	71	
-	2	2	2-18032-2	SCR, SET, FLT PNT, M3 X 10.0	70	
-	1	1	2119943-1	WASHER, SPACER	69	
-	1	1	2119740-1	TAG, IDENTIFICATION	67	
-	2	2	2168078-1	SCREW, DRIVE, RH, RoHS, 2 x .188	66	
-	1	1	5-18022-5	SCR, HEX HD CAP, M4 X 6.0	59	
-	-	1	2063961-1	FEED FINGER	58	
-	4	4	2168400-4	SHCS, LOW HEAD, RoHS, M4 X 8	57	
-	2	2	1-2168083-0	SCR, SKT HD CAP, RoHS, M4 X 10	56	
-	2	2	5018030-1	NUT, HEX, REG, RoHS, M3	54	
-	2	2	986965-8	NUT, LOCK, HEX, TORQUE (M4)	53	
-	1	-	2119792-2	PAWL, EF, AIR	51	
-	1	2	18023-9	SCR, SKT HD CAP M4 X 6.0	49	
-	-	1	2119652-1	FEED CAM, PRE FEED	48	
-	1	1	1803602-1	SCR, BHSC, RoHS (M8 X 25)	41	
-	8	8	1-18028-2	WASHER, FLAT, REG M4	33	
-	2	2	2168083-9	SCR, SKT HD CAP, RoHS, M4 X 20	31	
-	2	2	2168083-2	SCR, SKT HD CAP, RoHS, M4 X 8.0	29	
-	1	1	690455-1	STRIPPER, FRONT CASTING	27	
-	2	2	1-2168083-5	SCR, SKT HD CAP, RoHS, M4 X 30	25	
-	1	1	1752371-1	PLATE, STRIP GUIDE	24	
-	2	2	2-22281-3	SPRING, COMPRESSION	22	
-	1	1	1803292-4	DRAG	20	
-	1	1	1901696-4	STRIP GUIDE, REAR	19	
-	1	1	1901695-4	STRIP GUIDE, FRONT	18	
-	1	1	1-240641-1	SPACER	16	
1	-	1	240644-1	PLATE, REAR SHEAR	11	
-	-	-	-	-	10	
-	1	1	690482-5	PLATE, FRONT SHEAR	9	
1	1	1	3-1803059-9	ANVIL, COMBINATION, END FEED	8	
1	-	1	2217206-7	BLADE, SLUG	7	
-	-	-	-	-	6	
-	1	1	240641-8	SPACER	5	
-	1	1	238011-2	BLOCK, CRIMPER SPACER	4	
1	1	1	2-1633961-5	CRIMPER, INSULATION F PREMIUM	3	
-	1	1	455888-9	SPACER, CRIMPER	2	
1	1	1	456412-7	CRIMPER, WIRE .180 F PREMIUM	1	
-	77	22	21	PART NO	DESCRIPTION	ITEM NO

PACIFIC VERSION
Shown on sheets 3 of 4 & 4 of 4
(Atlantic version shown on sheets 1 of 4 & 2 of 4)

DIMENSIONS: mm		TOLERANCES UNLESS OTHERWISE SPECIFIED:		DWG: X.ZHAO 06FEB2016		CHK: L.ZHANG 06FEB2016		APVD: J.GUO 06FEB2016		NAME: Ocean End Feed Applicator	
0 PLC ±		1 PLC ±		2 PLC ±		3 PLC ±		4 PLC ±		SIZE: A1	
ANGLES		FINISH		WEIGHT		SCALE: 1:1		SHEET: 3 OF 4		REV: C	
Customer Accessible Production Drawing										Customer Accessible Production Drawing	

LOC		DIST		REVISIONS			
A	66	P	LTM	DESCRIPTION	DATE	DWN	APVD
		-		SEE SHEET 1			

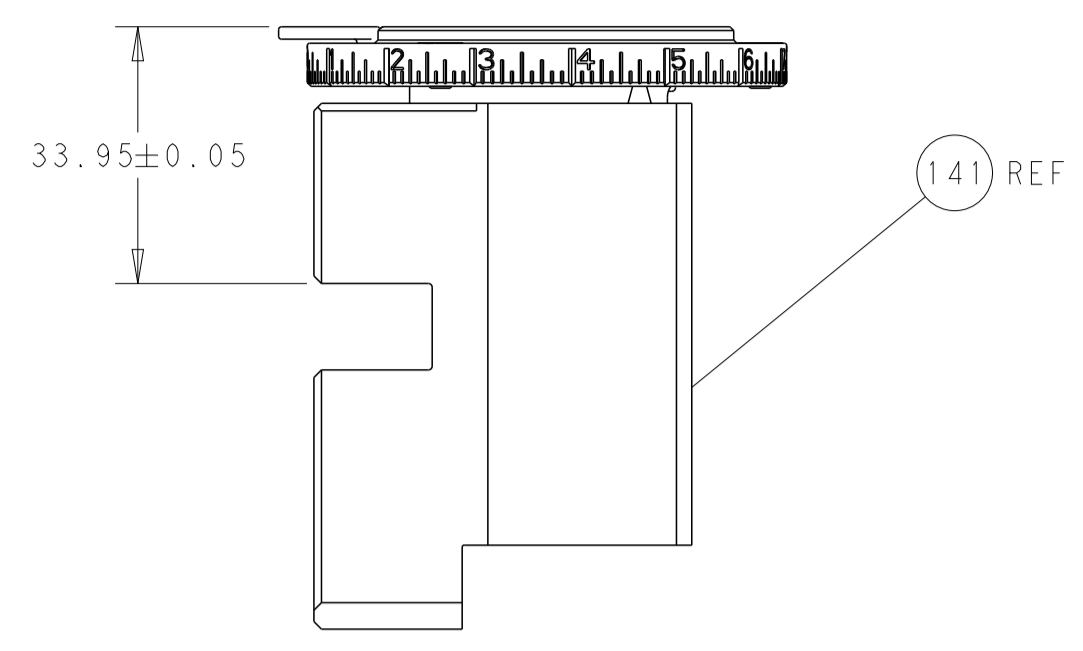

RAM SET-UP

FEED TYPE
MECHANICAL

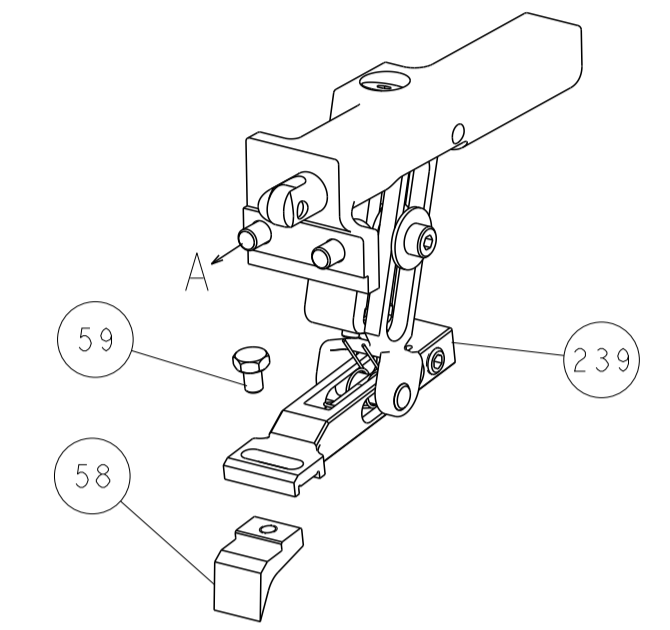

PNEUMATIC

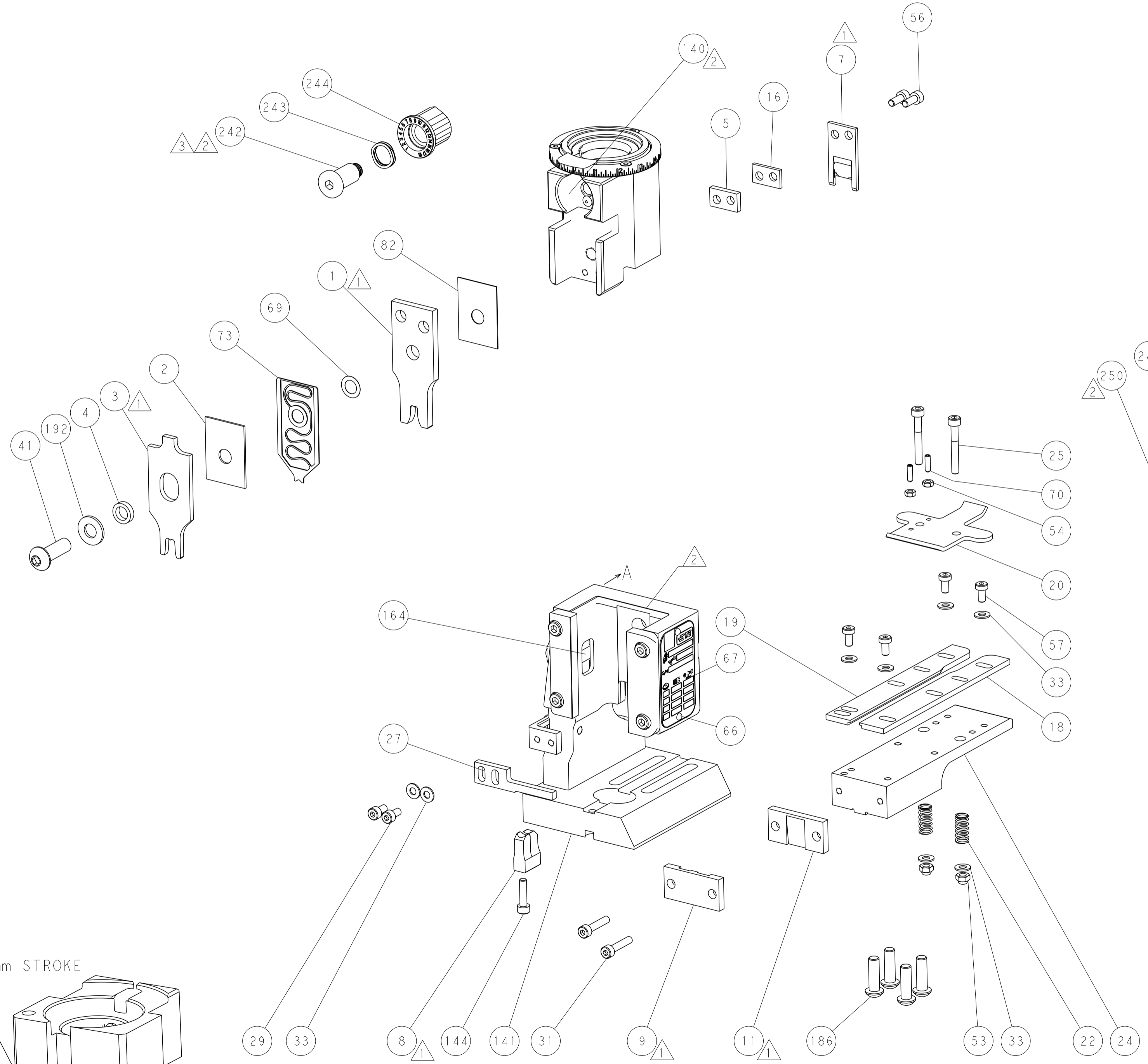
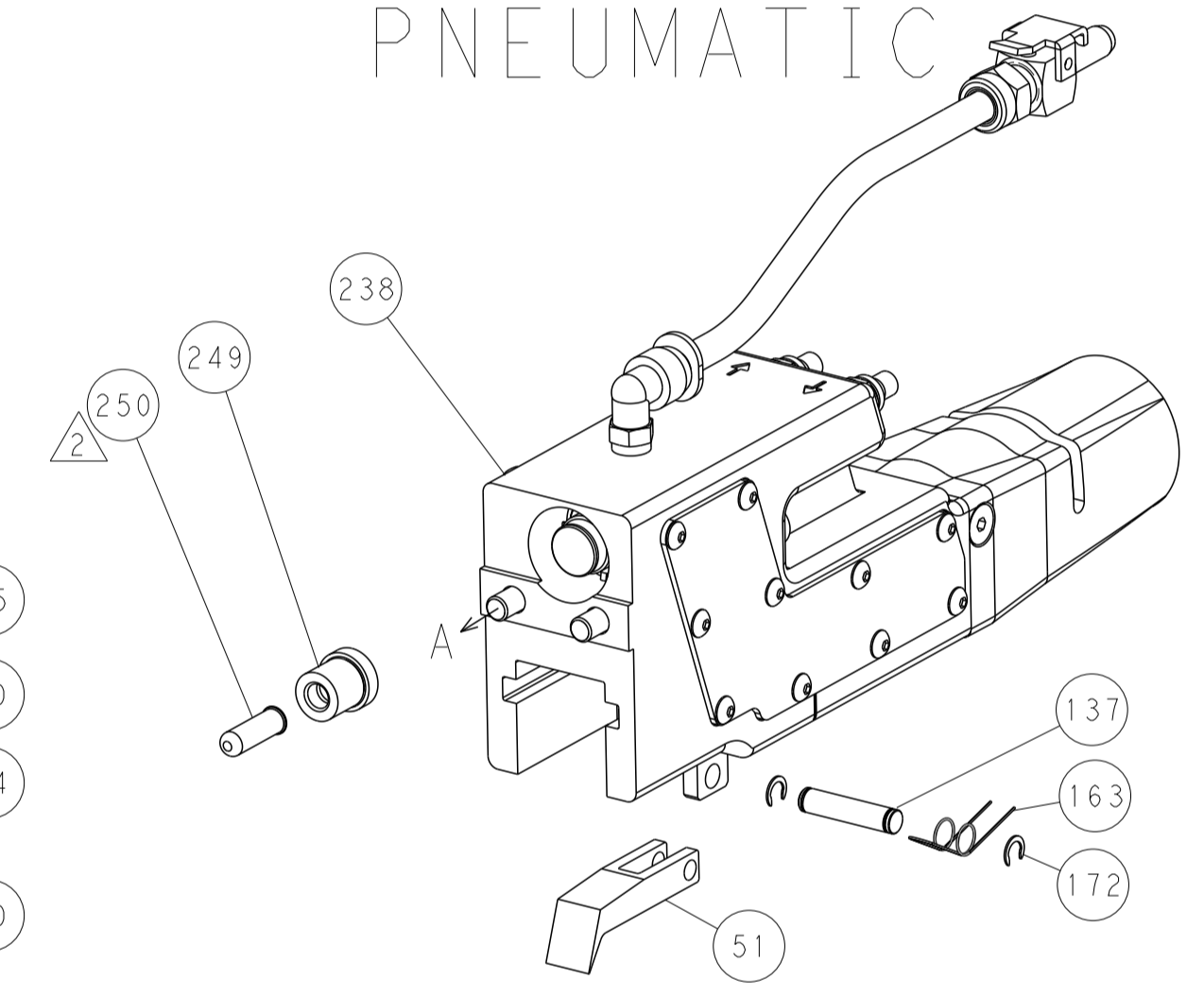

CAM POSITIONS

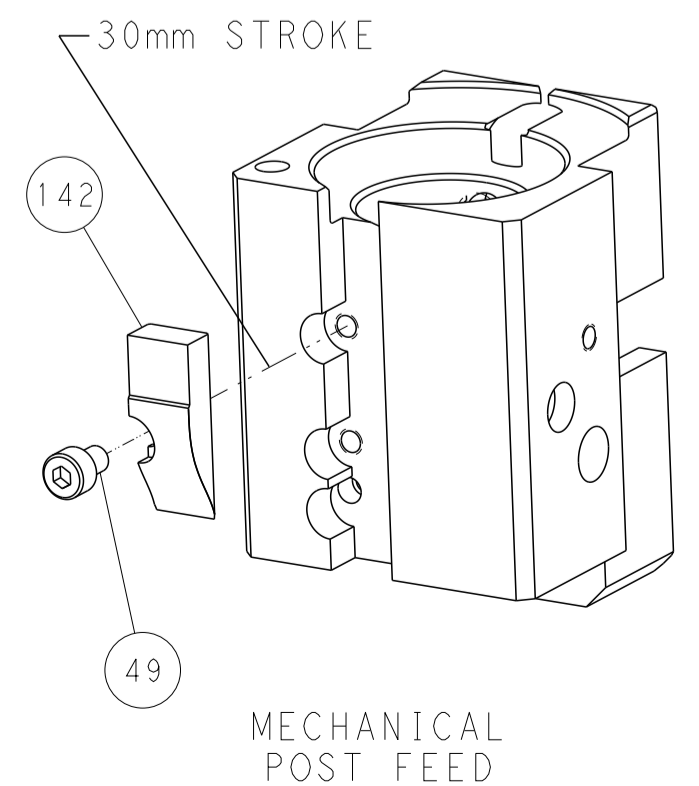

MECHANICAL POST FEED

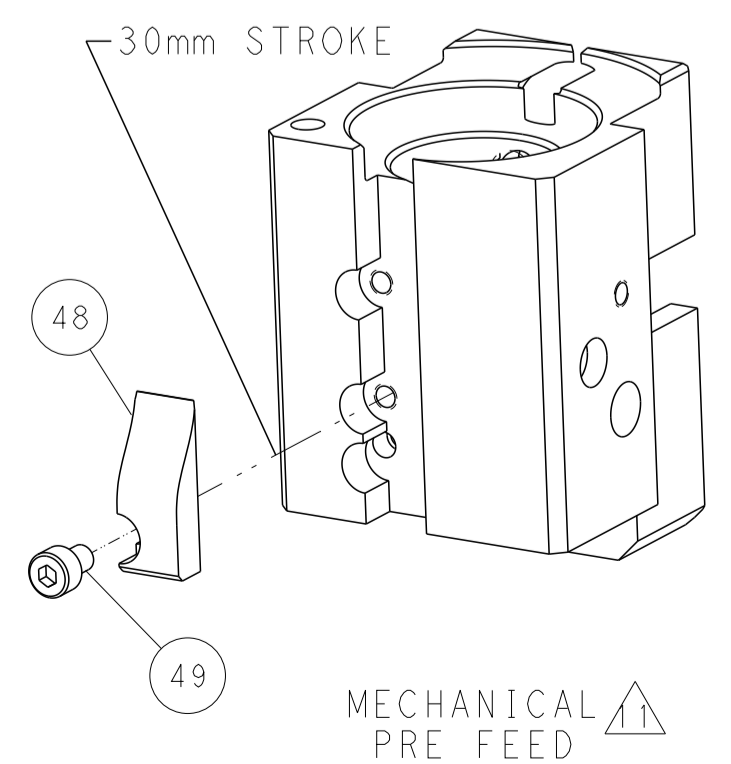

MECHANICAL PRE FEED

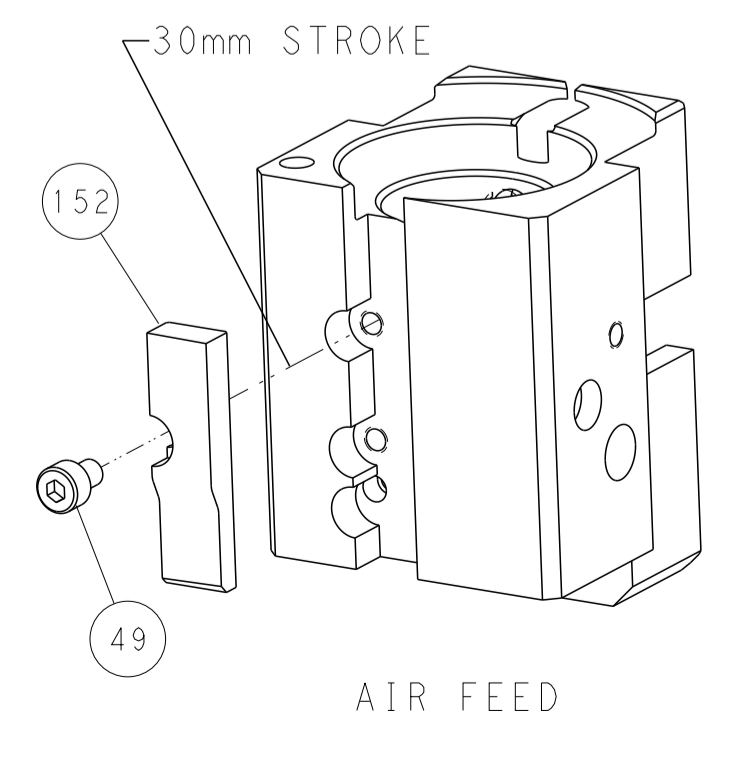

AIR FEED

PACIFIC VERSION
 Shown on sheets 3 of 4 & 4 of 4
 (Atlantic version shown on sheets 1 of 4 & 2 of 4)

DIMENSIONS:		TOLERANCES UNLESS OTHERWISE SPECIFIED:		DWN X.ZHAO 06FEB2016		CHK L.ZHANG 06FEB2016		APVD JJ.GUO 06FEB2016		NAME		STE TE Connectivity Harrisburg, PA 17105-3608	
mm	0 PLC	±		PRODUCT SPEC		SIZE	CAGE CODE	DRAWING NO	RESTRICTED TO				
	1 PLC	±		APPLICATION SPEC		WEIGHT		A 00779	Customer Accessible Production Drawing	SCALE	1:1	SHEET	4 of 4
	2 PLC	±						©=2150639					REV
	3 PLC	±											C
	4 PLC	±											
	ANGLES	±											
	FINISH												

Mouser Electronics

Authorized Distributor

Click to View Pricing, Inventory, Delivery & Lifecycle Information:

[TE Connectivity:](#)

[2150639-2](#)