

PART NUMBER	REVISION	DESCRIPTION	FEED TYPE
2150343-1	E	FINE CRIMP HEIGHT ADJUST	MECHANICAL
2150343-2	E	FINE CRIMP HEIGHT ADJUST	PNEUMATIC
7-2150343-1	E	MECHANICAL AND CRIMP TOOLING KIT	MECHANICAL
7-2150343-2	E	PNEUMATIC AND CRIMP TOOLING KIT	PNEUMATIC
7-2150343-7	C	CRIMP TOOLING KIT	-

ATLANTIC VERSION TERMINATOR INTERFACE ADAPTER

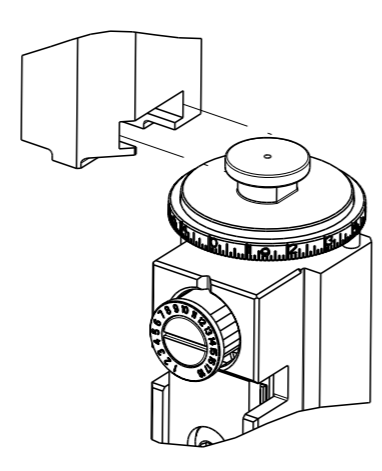

APPLICATOR DATA		
CRIMP	SIZE	TYPE
WIRE	2.03 mm [.080]	F
INSUL	2.29 mm [.090]	O
APPLICATOR INSTRUCTIONS 408-35043		

TERMINAL DATA: TE TERMINAL TE CRIMP SPECIFICATION			
TERMINAL NAME: RING			
WIRE STRIP LENGTH 3.94-4.70 mm [.155-.185 IN]		INSULATION DIAMETER RANGE Ø1.22-1.98 mm [.048-.078 IN]	
TERMINAL APPLICATION SPECIFICATION 114-2084			
TERMINALS APPLIED			
TE TERMINAL	TE TERMINAL	TE TERMINAL	TE TERMINAL
42164-2	42508-2	63721-1	
42164-3	42508-3		

TERMINAL DATA: TE TERMINAL TE CRIMP SPECIFICATION			
TERMINAL NAME: RING			
WIRE STRIP LENGTH 0.14-0.16 mm [.006-.006 IN]		INSULATION DIAMETER RANGE Ø1.65-1.91 mm [.065-.075 IN]	
TERMINAL APPLICATION SPECIFICATION			
TERMINALS APPLIED			
TE TERMINAL	TE TERMINAL	TE TERMINAL	TE TERMINAL
42508-2			

WIRE SIZE	CRIMP HEIGHT mm [INCH]	CRIMP HEIGHT REFERENCE SETTING
20 AWG	1.40 +/- 0.05 [0.055 +/- .002]	7.6
22 AWG	1.35 +/- 0.05 [0.053 +/- .002]	8.2
24 AWG	1.27 +/- 0.05 [0.050 +/- .002]	9.0

WIRE SIZE	CRIMP HEIGHT mm [INCH]	CRIMP HEIGHT REFERENCE SETTING
0.35mm ²	1.35 +/- 0.05 [0.053 +/- .002]	8.2

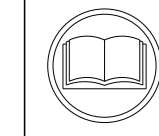

- 1 RECOMMENDED SPARE PARTS
- 2 REFER TO SUPPLIED INSTRUCTION SHEET FOR CLEANING, LUBRICATION AND STORAGE OF APPLICATOR.
- 3 APPLY PART NUMBER 2-23419-6 LOCTITE TO THREADS OF ITEM 242.
- 4 CRIMP HEIGHT REFERENCE SETTING WAS THE SETTING USED WHEN THE APPLICATOR WAS QUALIFIED AT THE FACTORY. ADJUSTMENT MAY BE NECESSARY WHEN RUNNING APPLICATOR IN THE FIELD.
- 5 TERMINAL LUBRICANT IS RECOMMENDED.
- 6 THIS CRIMP PARAMETER IS PROVIDED TO MEET A CUSTOM AND UNIQUE CUSTOMER REQUIREMENT. IT HAS BEEN EVALUATED AND IS CONDITIONALLY SPECIFIED BY TE CONNECTIVITY. THIS CUSTOMIZED CRIMP PARAMETER IS NOT LISTED AS AN APPROVED APPLICATION WITHIN A TE CONNECTIVITY APPLICATION SPECIFICATION; HOWEVER, IT HAS BEEN VALIDATED ACCORDING TO TE CONNECTIVITY SPECIFICATIONS 109-18079 (TEST GROUP 1) AND 114-18022. **TE CONNECTIVITY EXPRESSLY DISCLAIMS ANY AND ALL WARRANTIES THAT THE PRODUCT WILL PERFORM SIMILARLY TO VALIDATED AND APPROVED APPLICATIONS, AS STATED WITHIN TE CONNECTIVITY APPLICATION SPECIFICATIONS, INCLUDING BUT NOT LIMITED TO IMPLIED WARRANTIES OF MERCHANTABILITY OR FITNESS FOR PARTICULAR PURPOSE.** AS SUCH, IT IS HIGHLY RECOMMENDED THAT THE CUSTOMER PERFORM FURTHER DETAILED EVALUATION TO ASSESS PRODUCT PERFORMANCE IN THE SPECIFIC APPLICATION.
- 7. UNLESS SPECIFIED OTHERWISE TORQUE VALUES SHALL BE USED PER DOCUMENT, 101-35000.

***WARNING**
 ON INSTALLATION, SET WIRE DISC TO CRIMP HEIGHT REFERENCE SETTING FOR LARGEST WIRE SIZE. CRIMP HEIGHT REFERENCE SETTINGS GREATER THAN THE VALUE SHOWN MAY CAUSE DAMAGE TO THE CRIMP TOOLING, REFER TO THE INSTRUCTION SHEET FOR PROPER SETUP AND ADJUSTMENTS.

ATLANTIC VERSION
 Shown on sheets 1 of 4 & 2 of 4
 (Pacific version shown on sheets 3 of 4 & 4 of 4)

LOC	DIST	REVISIONS					
A	66	#	LY#	DESCRIPTION	DATE	OWN	APVD
		C		ECR-16-014187	06OCT2016	LG	JD
		C1		ECR-18-007834	22MAY2018	AW	JD
		D		ECR-18-017346	02NOV2018	CT	TB
		E		ECR-19-000041	02JAN2019	JAH	TE

-	1	-	1	-	2119640-1	PUSH ROD, AIR FEED	250	
-	1	-	1	-	1803259-1	BUSHING, FLANGED	249	
-	1	-	1	-	2119641-1	FEED CAM, AIR FEED	248	
-	1	1	1	1	2119082-9	CAM, SNAIL, INSULATION ADJUSTMENT	244	
-	1	1	1	1	2079764-1	WASHER, WAVE SPRING, CREST-TO-CREST	243	
-	1	1	1	1	2119083-1	RETAINER, INSULATION DIAL	242	
-	-	1	-	1	2119580-1	MECHANICAL FEED ASSEMBLY	239	
-	1	-	1	-	2063440-1	AIR FEED MODULE	238	
-	1	1	1	1	1-18028-0	WASHER, FLAT, REG M8	192	
-	2	-	2	-	21045-3	RING, RETAIN, EXTERN, 3/16 CRESCENT	172	
-	REF	REF	REF	REF	994970-2	COUNTER, MAGNETIC	164	
-	1	-	1	-	240638-1	SPRING, FEED FINGER	163	
-	1	-	1	-	3-23627-7	PIN, RETAIN, GRVD, 3/16 X .854	137	
-	1	1	1	1	2119955-2	ASSY, LUBRICATOR, END FEED	84	
-	1	1	1	1	455888-4	SPACER, CRIMPER	82	
-	1	1	1	1	2119791-9	DEPRESSOR, WIRE	73	
-	1	1	1	1	1803607-2	DOCUMENTATION PACKAGE	71	
-	2	2	2	2	2-18032-2	SCR, SET, FLT PNT, M3 X 10.0	70	
-	1	1	1	1	2119740-1	TAG, IDENTIFICATION	67	
-	2	2	2	2	2168078-1	SCREW, DRIVE, RH, RoHS, 2 x .188	66	
-	1	1	1	1	2168083-2	SCR, SKT HD CAP, RoHS, M4 X 8.0	60	
-	-	1	-	1	5-18022-5	SCR, HEX HD CAP, M4 X 6.0	59	
-	-	1	-	1	2063961-1	FEED FINGER	58	
-	4	4	4	4	2168400-4	SHCS, LOW HEAD, RoHS, M4 X 8	57	
-	2	2	2	2	2-2168083-5	SCR, SKT HD CAP, RoHS, M4 X 14	56	
-	2	2	2	2	5018030-1	NUT, HEX, REG, RoHS, M3	54	
-	2	2	2	2	986965-8	NUT, LOCK, HEX, TORQUE (M4)	53	
-	1	-	1	-	2119792-2	PAWL, EF, AIR	51	
-	1	2	1	2	18023-9	SCR, SKT HD CAP M4 X 6.0	49	
-	-	1	-	1	2119652-1	FEED CAM, PRE FEED	48	
-	-	1	-	1	2119653-1	FEED CAM, POST FEED	47	
-	1	1	1	1	2119655-5	APPLICATOR BASIC ASSEMBLY, EF	46	
-	1	1	1	1	1803517-1	RAM ASSEMBLY, EF ATLANTIC	44	
-	1	1	1	1	1803602-1	SCR, BHSC, RoHS (M8 X 25)	41	
-	8	8	8	8	1-18028-2	WASHER, FLAT, REG M4	33	
-	2	2	2	2	2168083-9	SCR, SKT HD CAP, RoHS, M4 X 20	31	
-	2	2	2	2	1-2168083-0	SCR, SKT HD CAP, RoHS, M4 X 10	29	
-	1	1	1	1	240639-1	STRIPPER (MACHINING)	27	
-	2	2	2	2	1-2168083-5	SCR, SKT HD CAP, RoHS, M4 X 30	25	
-	1	1	1	1	1752371-5	PLATE, STRIP GUIDE	24	
-	2	2	2	2	2-22281-3	SPRING, COMPRESSION	22	
-	1	1	1	1	1803292-4	DRAG	20	
-	1	1	1	1	1901696-2	STRIP GUIDE, REAR	19	
-	1	1	1	1	1901695-2	STRIP GUIDE, FRONT	18	
-	4	4	4	4	1-2079383-1	SCR, BHSC, RoHS (M6 X 12)	17	
-	1	1	1	1	240644-1	PLATE, REAR SHEAR	11	
-	-	-	-	-	-	-	10	
-	1	1	1	1	690482-7	PLATE, FRONT SHEAR	9	
-	1	2	2	1	1	3-1333216-3	ANVIL, COMBINATION	8
-	1	1	1	1	1	1-2217206-7	BLADE, SLUG	7
-	-	-	-	-	-	-	6	
-	1	1	1	1	1	6-240641-0	SPACER	5
-	1	1	1	1	1	6-238011-7	BLOCK, CRIMPER SPACER	4
-	1	2	2	1	1	1-2119784-8	CRIMPER, INSULATION O PREMIUM	3
-	-	-	-	-	-	-	2	
-	1	2	2	1	1	1633730-5	CRIMPER, WIRE	1
-	77	72	71	2	1	PART NO	DESCRIPTION	ITEM NO

DIMENSIONS:		TOLERANCES UNLESS OTHERWISE SPECIFIED:		MATERIAL:		FINISH:		WEIGHT:		SCALE:		SHEET:		REV:				
mm	0 PLC ±	1 PLC ±	2 PLC ±	3 PLC ±	4 PLC ±	ANGLES	FINISH	-	-	Customer Accessible Production Drawing	SCALE	1:1	SHEET	1	OF	4	REV	E

TE Connectivity
 Harrisburg, PA 17105-3608

STE

Ocean End Feed
 Applicator

SIZE: A1 CAGE CODE: 00779 DRAWING NO: 2150343

LOC	DIST	REVISIONS					
A	66	P	LYR	DESCRIPTION	DATE	OWN	APVD
		-		SEE SHEET 1	-	-	-

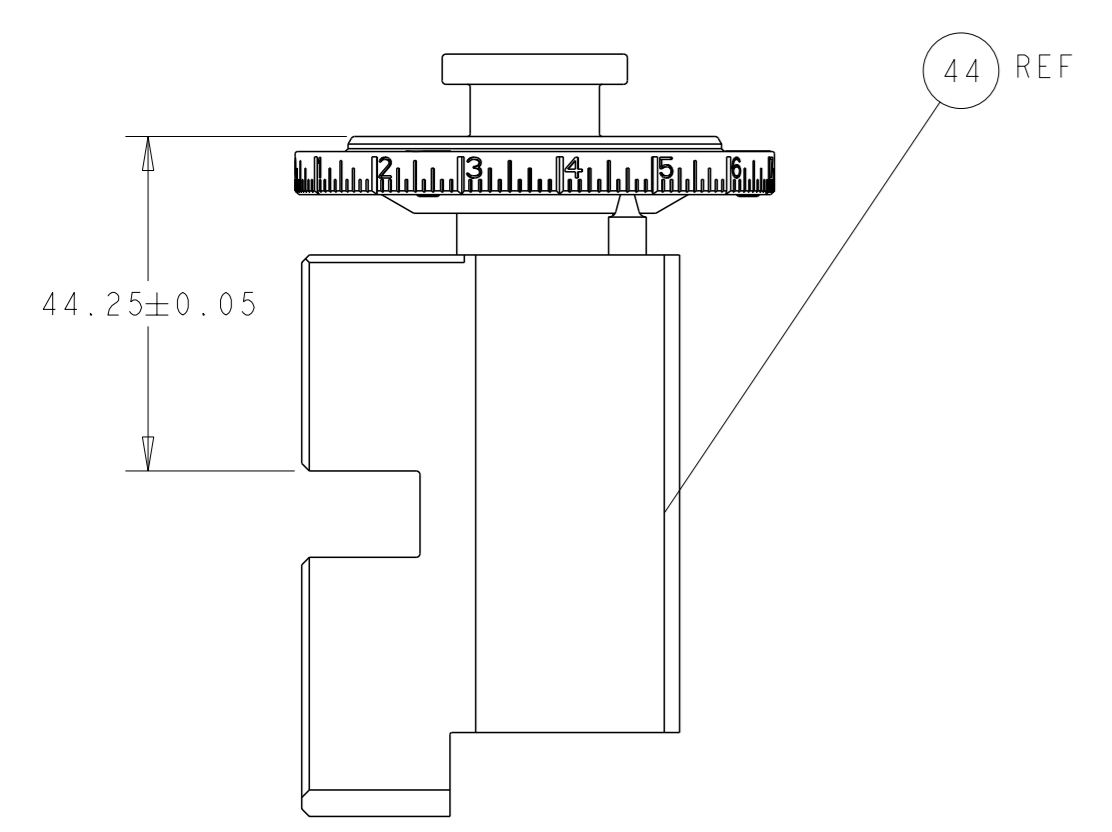

RAM SET-UP

FEED TYPE
MECHANICAL

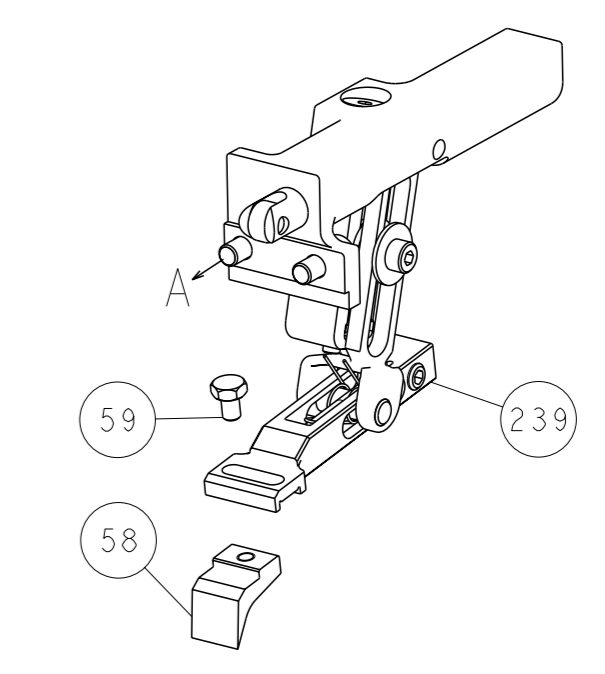

PNEUMATIC

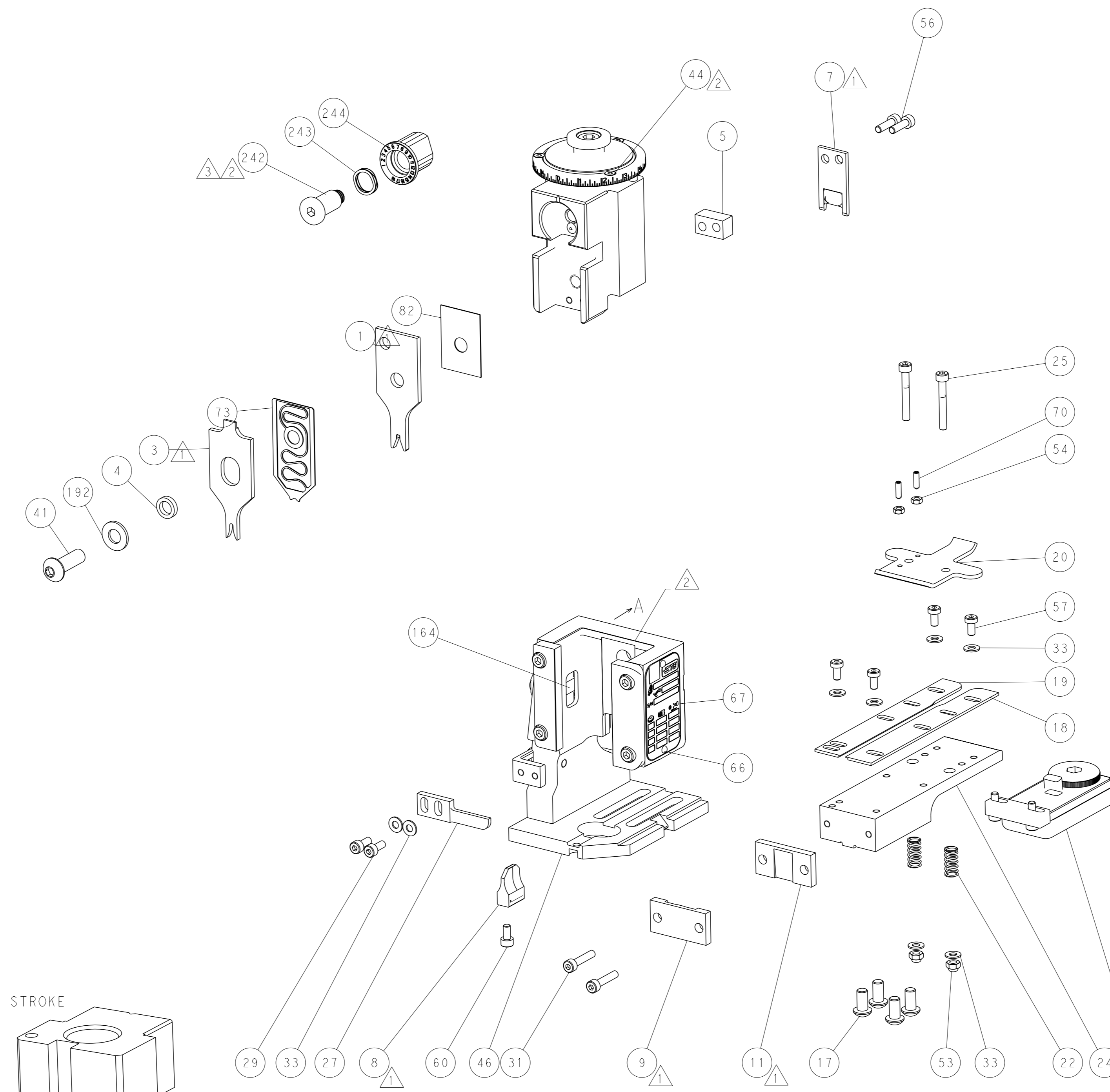
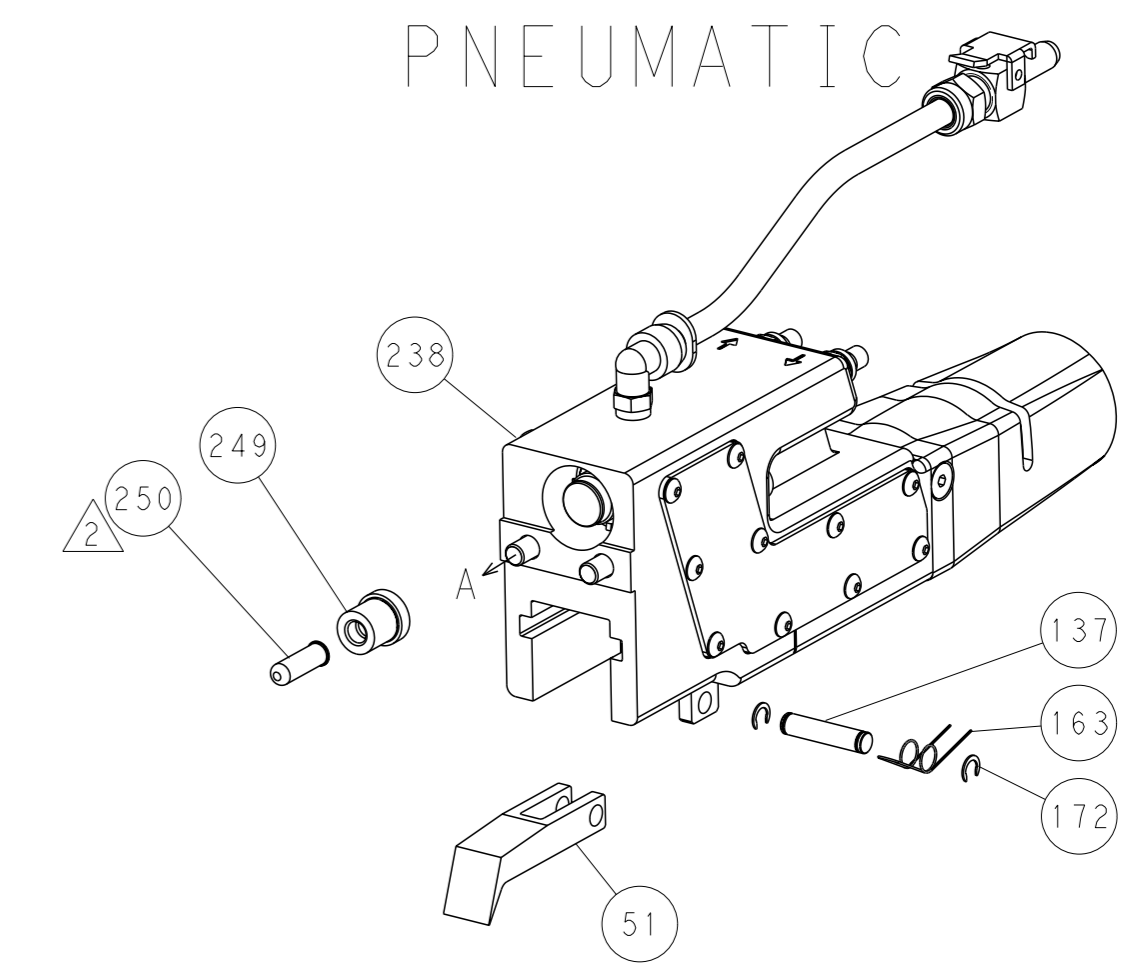

CAM POSITIONS

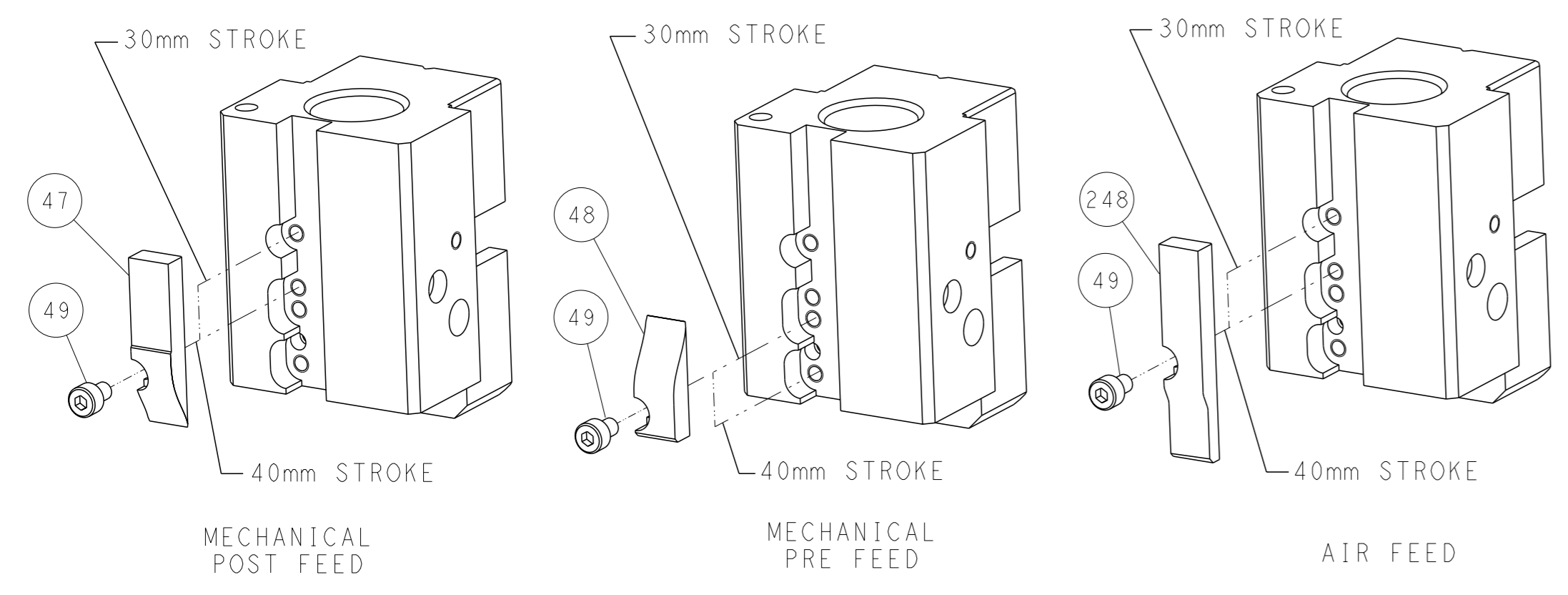

ATLANTIC VERSION
 Shown on sheets 1 of 4 & 2 of 4
 (Pacific version shown on sheets 3 of 4 & 4 of 4)

<small>THIS DRAWING IS A CONTROLLED DOCUMENT FROM TYCO ELECTRONICS CORPORATION. IT IS SUBJECT TO CHANGE AND THE CONTROL AND REVISIONS ORGANIZATION SHOULD BE CONTACTED FOR THE LATEST REVISION.</small>		OWN: Y. YIN 13JUN2013 CHK: G. BAILEY 13JUN2013 APVD: H. GUO 13JUN2013	NAME: Ocean End Feed Applicator SIZE: A1 CAGE CODE: 00779 DRAWING NO: 2150343	TE Connectivity Harrisburg, PA 17105-3608
DIMENSIONS: mm TOLERANCES UNLESS OTHERWISE SPECIFIED: 0 PLC ± 1 PLC ± 2 PLC ± 3 PLC ± 4 PLC ± ANGLES FINISH ±	WEIGHT: - SCALE: 1:1 SHEET: 2 of 4 REV: E	RESTRICTED TO: -		

PART NUMBER	REVISION	DESCRIPTION	FEED TYPE
2-2150343-1	E	FINE CRIMP HEIGHT ADJUST	MECHANICAL
2-2150343-2	E	FINE CRIMP HEIGHT ADJUST	PNEUMATIC
7-2150343-7	C	CRIMP TOOLING KIT	-

PACIFIC VERSION TERMINATOR
INTERFACE ADAPTER

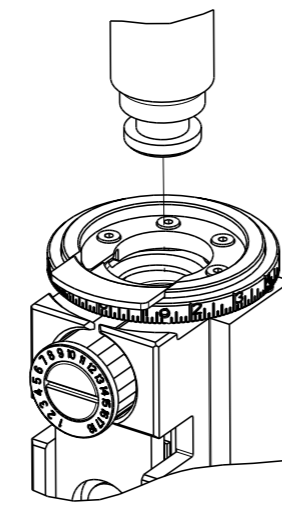

APPLICATOR DATA		
CRIMP	SIZE	TYPE
WIRE	2.03 mm [.080]	F
INSUL	2.29 mm [.090]	O
APPLICATOR INSTRUCTIONS 408-35043		

TERMINAL DATA: TE TERMINAL				TE CRIMP SPECIFICATION			
TERMINAL NAME: RING							
WIRE STRIP LENGTH 3.94-4.70 mm [.155-.185 IN]				INSULATION DIAMETER RANGE Ø1.22-1.98 mm [.048-.078 IN]			
TERMINAL APPLICATION SPECIFICATION 114-2084							
TERMINALS APPLIED							
TE TERMINAL	TE TERMINAL	TE TERMINAL	TE TERMINAL	TE TERMINAL	TE TERMINAL	TE TERMINAL	TE TERMINAL
42164-2	42508-2	63721-1					
42164-3	42508-3						

TERMINAL DATA: TE TERMINAL				TE CRIMP SPECIFICATION			
TERMINAL NAME: RING							
WIRE STRIP LENGTH 0.14-0.16 mm [.006-.006 IN]				INSULATION DIAMETER RANGE Ø1.65-1.91 mm [.065-.075 IN]			
TERMINAL APPLICATION SPECIFICATION							
TERMINALS APPLIED							
TE TERMINAL	TE TERMINAL	TE TERMINAL	TE TERMINAL	TE TERMINAL	TE TERMINAL	TE TERMINAL	TE TERMINAL
42508-2							

WIRE SIZE	CRIMP HEIGHT mm [INCH]	CRIMP HEIGHT REFERENCE SETTING
20 AWG	1.40 +/- 0.05 [0.055 +/- .002]	7.6
22 AWG	1.35 +/- 0.05 [0.053 +/- .002]	8.2
24 AWG	1.27 +/- 0.05 [0.050 +/- .002]	9.0

WIRE SIZE	CRIMP HEIGHT mm [INCH]	CRIMP HEIGHT REFERENCE SETTING
0.35mm2	1.35 +/- 0.05 [0.053 +/- .002]	8.2

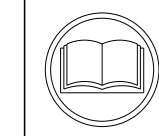

- 1 RECOMMENDED SPARE PARTS
 - 2 REFER TO SUPPLIED INSTRUCTION SHEET FOR CLEANING, LUBRICATION AND STORAGE OF APPLICATOR.
 - 3 APPLY PART NUMBER 2-23419-6 LOCTITE TO THREADS OF ITEM 242.
 - 4 CRIMP HEIGHT REFERENCE SETTING WAS THE SETTING USED WHEN THE APPLICATOR WAS QUALIFIED AT THE FACTORY. ADJUSTMENT MAY BE NECESSARY WHEN RUNNING APPLICATOR IN THE FIELD.
 - 5 TERMINAL LUBRICANT IS RECOMMENDED.
 - 6 THIS CRIMP PARAMETER IS PROVIDED TO MEET A CUSTOM AND UNIQUE CUSTOMER REQUIREMENT. IT HAS BEEN EVALUATED AND IS CONDITIONALLY SPECIFIED BY TE CONNECTIVITY. THIS CUSTOMIZED CRIMP PARAMETER IS NOT LISTED AS AN APPROVED APPLICATION WITHIN A TE CONNECTIVITY APPLICATION SPECIFICATION; HOWEVER, IT HAS BEEN VALIDATED ACCORDING TO TE CONNECTIVITY SPECIFICATIONS 109-18079 (TEST GROUP 1) AND 114-18022. **TE CONNECTIVITY EXPRESSLY DISCLAIMS ANY AND ALL WARRANTIES THAT THE PRODUCT WILL PERFORM SIMILARLY TO VALIDATED AND APPROVED APPLICATIONS, AS STATED WITHIN TE CONNECTIVITY APPLICATION SPECIFICATIONS, INCLUDING BUT NOT LIMITED TO IMPLIED WARRANTIES OF MERCHANTABILITY OR FITNESS FOR PARTICULAR PURPOSE.** AS SUCH, IT IS HIGHLY RECOMMENDED THAT THE CUSTOMER PERFORM FURTHER DETAILED EVALUATION TO ASSESS PRODUCT PERFORMANCE IN THE SPECIFIC APPLICATION.
7. UNLESS SPECIFIED OTHERWISE TORQUE VALUES SHALL BE USED PER DOCUMENT, 101-35000.

***WARNING**
ON INSTALLATION, SET WIRE DISC TO CRIMP HEIGHT REFERENCE SETTING FOR LARGEST WIRE SIZE. CRIMP HEIGHT REFERENCE SETTINGS GREATER THAN THE VALUE SHOWN MAY CAUSE DAMAGE TO THE CRIMP TOOLING. REFER TO THE INSTRUCTION SHEET FOR PROPER SETUP AND ADJUSTMENTS.

PACIFIC VERSION
Shown on sheets 3 of 4 & 4 of 4
(Atlantic version shown on sheets 1 of 4 & 2 of 4)

LOC	DIST	REVISIONS					
		P	LY#	DESCRIPTION	DATE	OWN	APVD
A	66	-	-	SEE SHEET 1	-	-	-

-	1	1	2119640-1	PUSH ROD, AIR FEED	250	
-	1	1	1803259-1	BUSHING, FLANGED	249	
-	1	1	2119082-9	CAM, SNAIL, INSULATION ADJUSTMENT	244	
-	1	1	2079764-1	WASHER, WAVE SPRING, CREST-TO-CREST	243	
-	1	1	2119083-1	RETAINER, INSULATION DIAL	242	
-	-	1	2119580-1	MECHANICAL FEED ASSEMBLY	239	
-	1	-	2063440-1	AIR FEED MODULE	238	
-	1	1	1-18028-0	WASHER, FLAT, REG M8	192	
-	4	4	2079383-9	SCR, BHSC, RoHS (M6 X 20)	186	
-	2	2	21045-3	RING, RETAIN, EXTERN, 3/16 CRESCENT	172	
-	REF	REF	994970-2	COUNTER, MAGNETIC	164	
-	1	1	240638-1	SPRING, FEED FINGER	163	
-	1	-	2119641-2	FEED CAM, AIR FEED	152	
-	1	1	2168083-8	SCR, SKT HD CAP, RoHS, M4 X 16	144	
-	-	1	2119653-2	FEED CAM, POST FEED	142	
-	1	1	2119655-6	APPLICATOR BASIC ASSEMBLY, EF	141	
-	1	1	1803518-1	RAM ASSEMBLY, EF PACIFIC	140	
-	1	1	3-23627-7	PIN, RETAIN, GRVD, 3/16 X .854	137	
-	1	1	2119955-2	ASSY, LUBRICATOR, END FEED	84	
-	1	1	455888-4	SPACER, CRIMPER	82	
-	1	1	2119791-9	DEPRESSOR, WIRE	73	
-	1	1	1803607-2	DOCUMENTATION PACKAGE	71	
-	2	2	2-18032-2	SCR, SET, FLT PNT, M3 X 10.0	70	
-	1	1	2119740-1	TAG, IDENTIFICATION	67	
-	2	2	2168078-1	SCREW, DRIVE, RH, RoHS, 2 x .188	66	
-	1	1	5-18022-5	SCR, HEX HD CAP, M4 X 6.0	59	
-	-	1	2063961-1	FEED FINGER	58	
-	4	4	2168400-4	SHCS, LOW HEAD, RoHS, M4 X 8	57	
-	2	2	2-2168083-5	SCR, SKT HD CAP, RoHS, M4 X 14	56	
-	2	2	5018030-1	NUT, HEX, REG, RoHS, M3	54	
-	2	2	986965-8	NUT, LOCK, HEX, TORQUE (M4)	53	
-	1	-	2119792-2	PAWL, EF, AIR	51	
-	1	2	18023-9	SCR, SKT HD CAP M4 X 6.0	49	
-	-	1	2119652-1	FEED CAM, PRE FEED	48	
-	1	1	1803602-1	SCR, BHSC, RoHS (M8 X 25)	41	
-	8	8	1-18028-2	WASHER, FLAT, REG M4	33	
-	2	2	2168083-9	SCR, SKT HD CAP, RoHS, M4 X 20	31	
-	2	2	1-2168083-0	SCR, SKT HD CAP, RoHS, M4 X 10	29	
-	1	1	240639-1	STRIPPER (MACHINING)	27	
-	2	2	1-2168083-5	SCR, SKT HD CAP, RoHS, M4 X 30	25	
-	1	1	1752371-5	PLATE, STRIP GUIDE	24	
-	2	2	2-22281-3	SPRING, COMPRESSION	22	
-	1	1	1803292-4	DRAG	20	
-	1	1	1901696-2	STRIP GUIDE, REAR	19	
-	1	1	1901695-2	STRIP GUIDE, FRONT	18	
-	1	1	240644-1	PLATE, REAR SHEAR	11	
-	-	-	-	-	10	
-	1	1	690482-7	PLATE, FRONT SHEAR	9	
-	1	1	3-1333216-3	ANVIL, COMBINATION	8	
-	1	1	1-2217206-7	BLADE, SLUG	7	
-	-	-	-	-	6	
-	1	1	6-240641-0	SPACER	5	
-	1	1	6-238011-7	BLOCK, CRIMPER SPACER	4	
-	1	1	1-2119784-8	CRIMPER, INSULATION O PREMIUM	3	
-	-	-	-	-	2	
-	1	1	1633730-5	CRIMPER, WIRE	1	
-	77	22	21	PART NO	DESCRIPTION	ITEM NO

DIMENSIONS:		TOLERANCES UNLESS OTHERWISE SPECIFIED:		APPROVED BY:		DATE:	
mm	0 PLC ±	1 PLC ±	2 PLC ±	3 PLC ±	4 PLC ±	FINISH	★
MATERIAL:		FINISH:		WEIGHT:		SCALE:	
Customer Accessible Production Drawing		SCALE: 1:1		SHEET 3 of 4		REV E	

LOC	DIST	REV	DESCRIPTION	DATE	OWN	APVD
A	66		SEE SHEET 1			

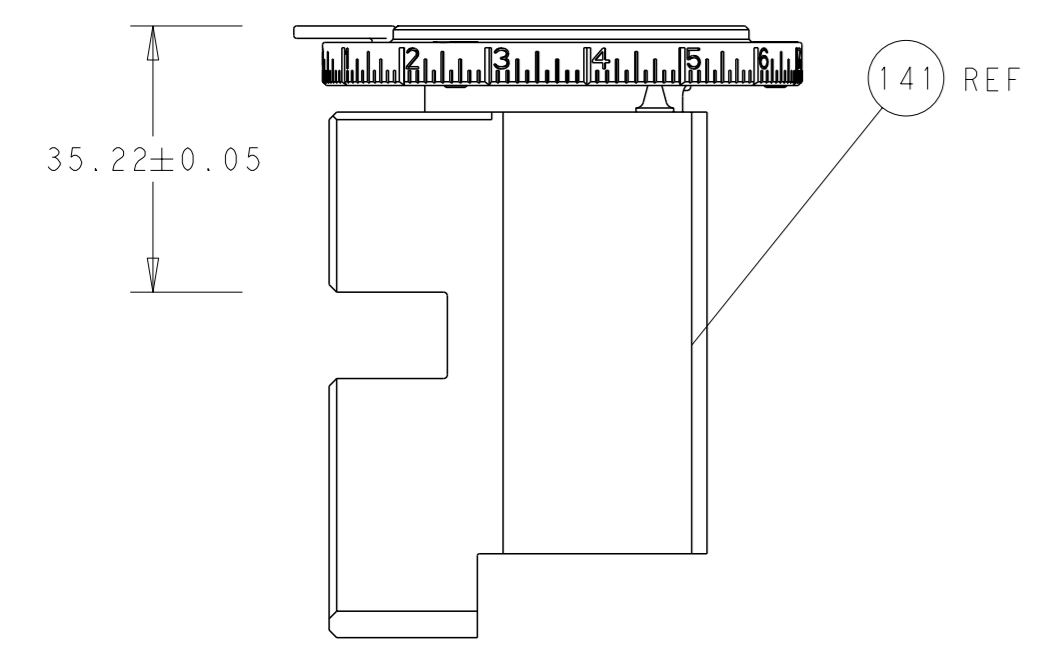

RAM SET-UP

FEED TYPE
MECHANICAL

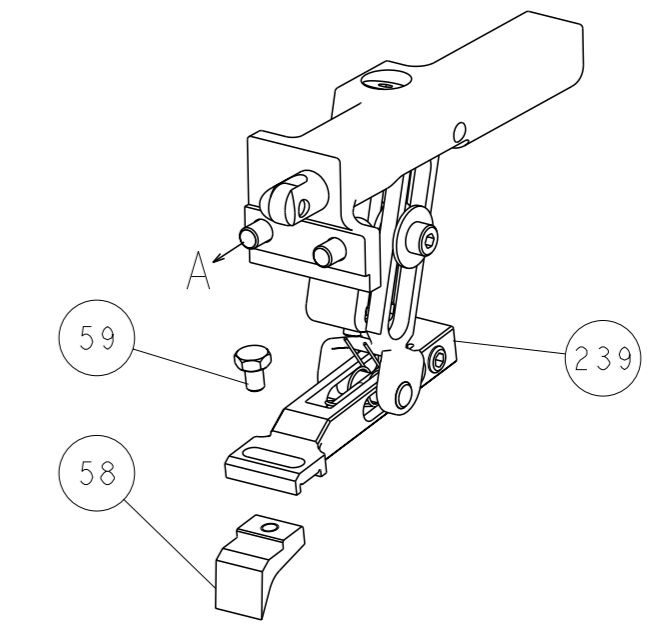

PNEUMATIC

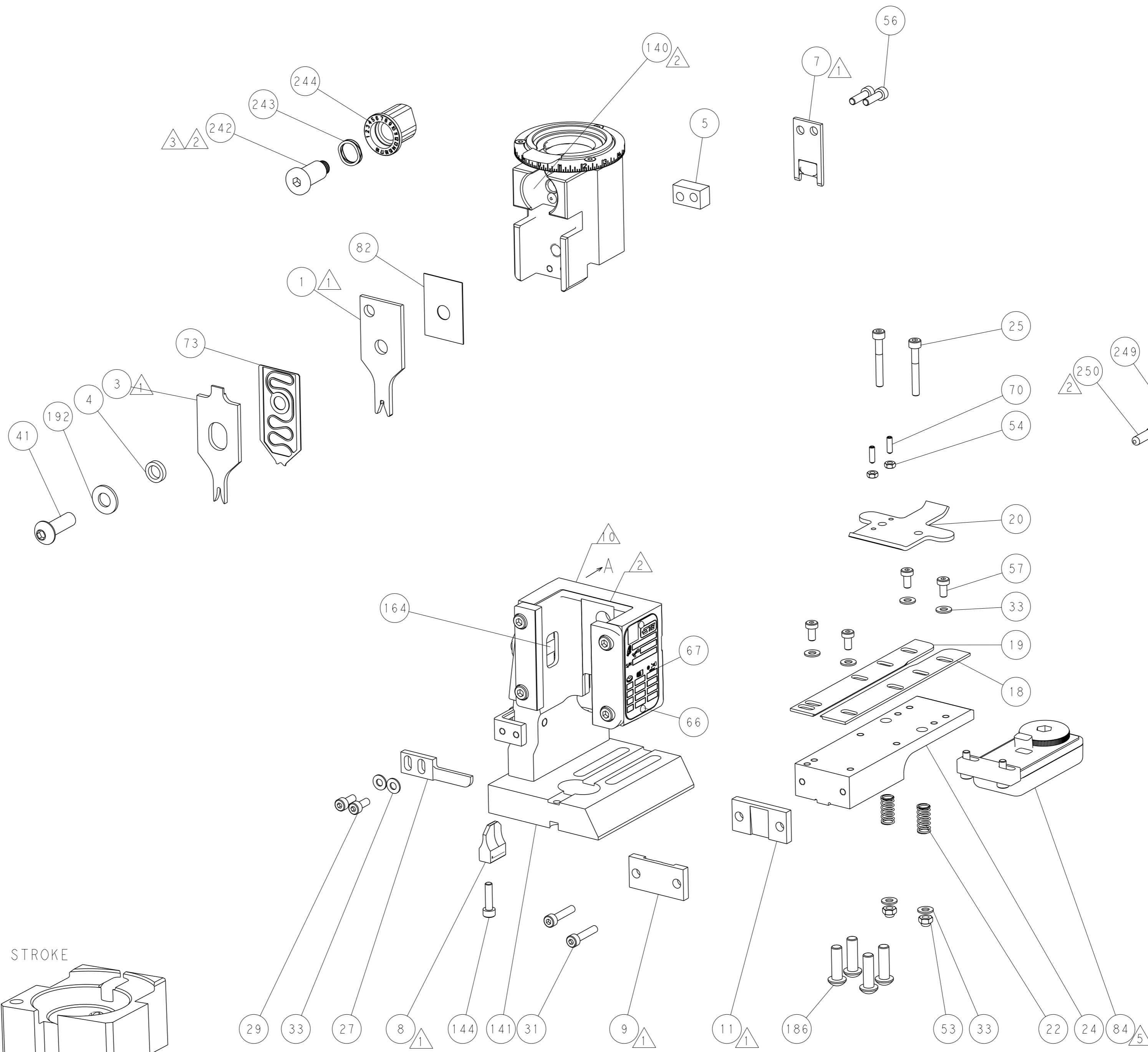
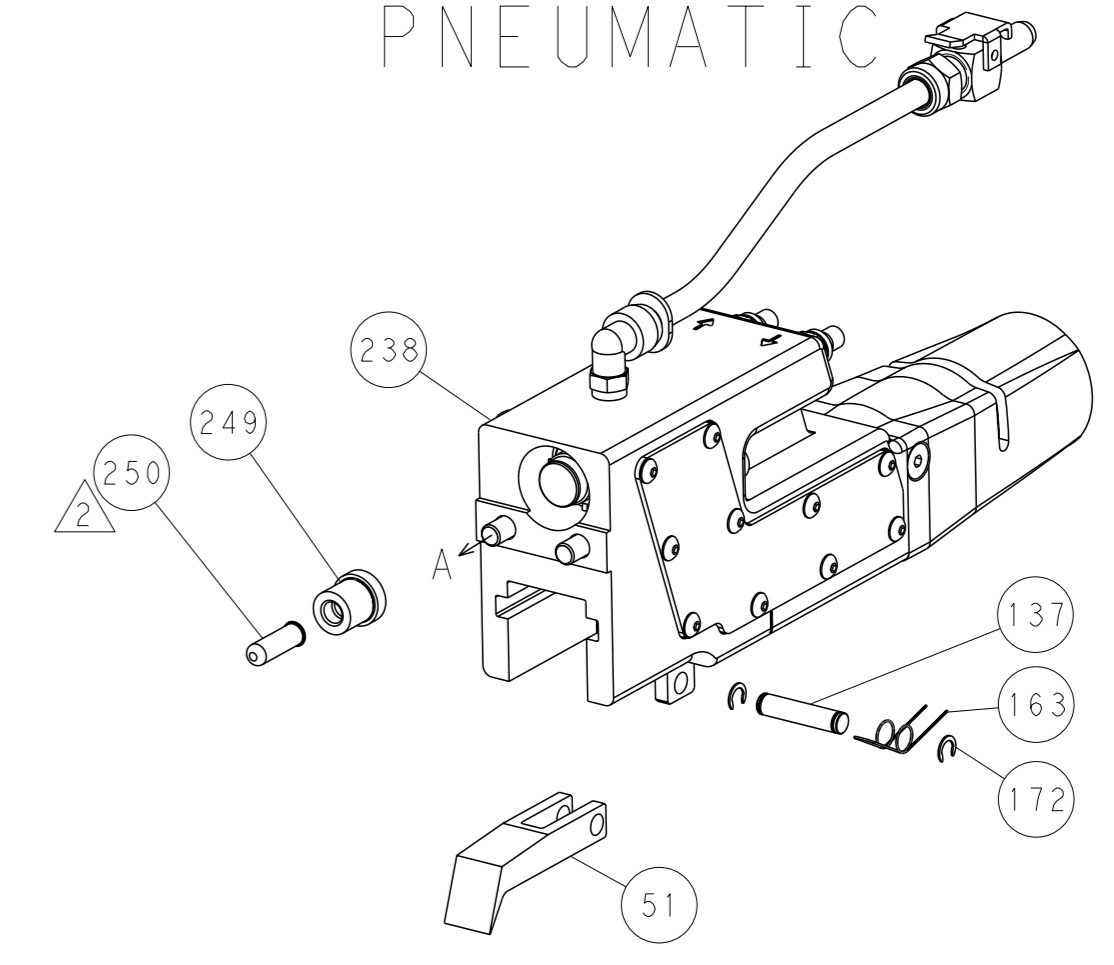

CAM POSITIONS

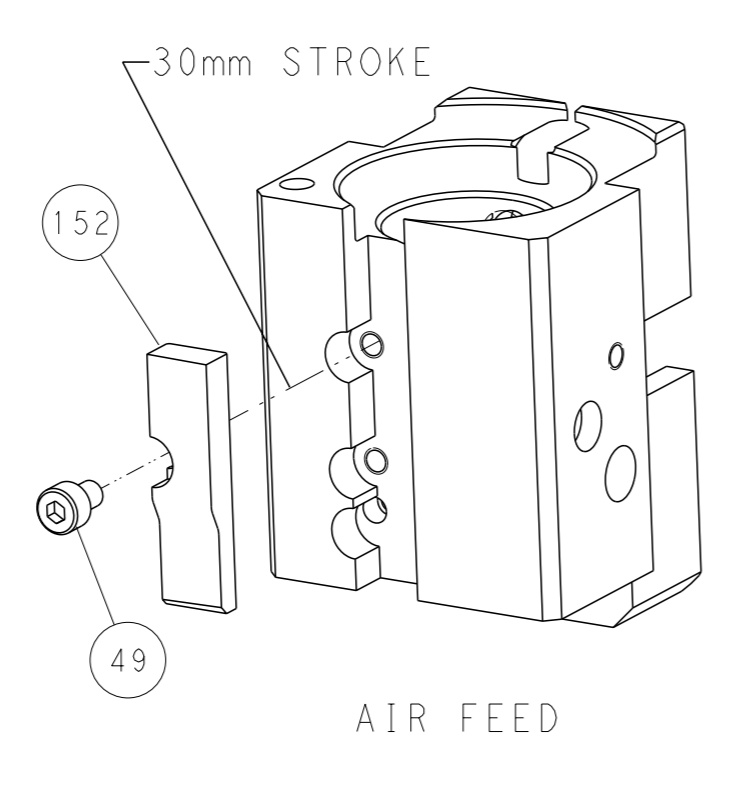
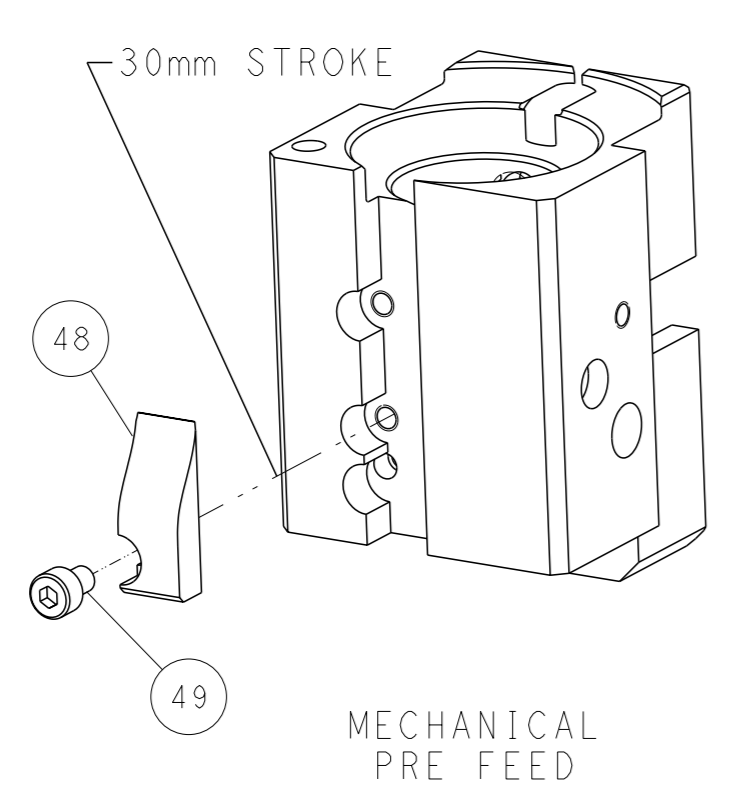
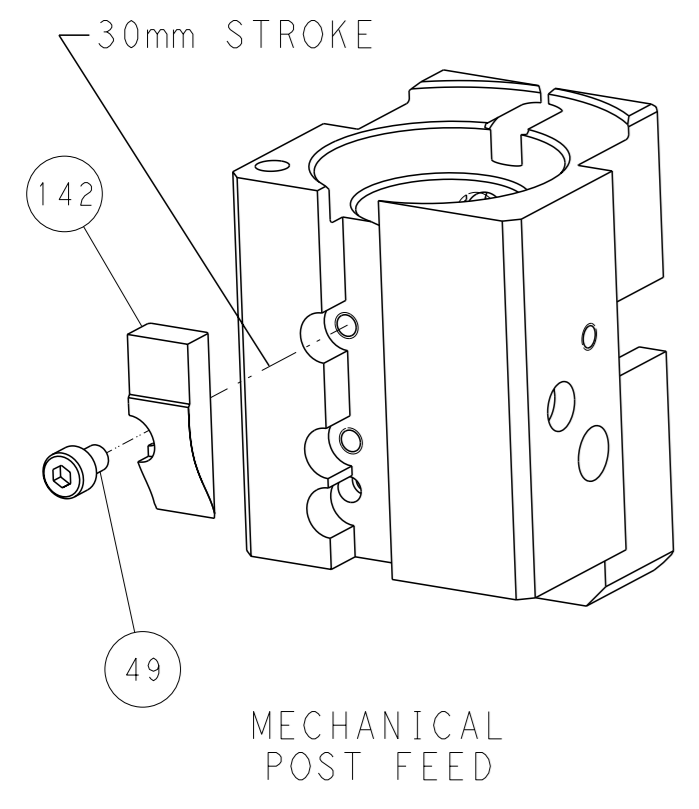

PACIFIC VERSION
 Shown on sheets 3 of 4 & 4 of 4
 (Atlantic version shown on sheets 1 of 4 & 2 of 4)

DIMENSIONS: mm 		TOLERANCES UNLESS OTHERWISE SPECIFIED: 0 PLC ± 1 PLC ± 2 PLC ± 3 PLC ± 4 PLC ± ANGLES ± FINISH *		OWN Y. YIN 13JUN2013 CHK G. BAILEY 13JUN2013 APVD JJ. GUO 13JUN2013 PRODUCT SPEC APPLICATION SPEC WEIGHT Customer Accessible Production Drawing		NAME Ocean End Feed Applicator SIZE CAGE CODE DRAWING NO A1 00779 C=2150343 SCALE 1:1 SHEET 4 OF 4 REV E		RESTRICTED TO	
-----------------------	--	---	--	---	--	--	--	---------------	--

Mouser Electronics

Authorized Distributor

Click to View Pricing, Inventory, Delivery & Lifecycle Information:

[TE Connectivity:](#)

[2150343-1](#)