



BAND (SUPPLIED FLAT) (3)(8)
(SEE PART NUMBER BREAKDOWN FOR OPTIONS)

CODE 40 - BANDING BACKSHELL

BNX40AB00-1608 -S

SERIES _____
 BNX - BAND STRAP NOT INCLUDED
 BND - BAND STRAP INCLUDED
 (SEE BAND TERMINATION CONFIGURATION)
 CONNECTOR INTERFACE _____
 MATERIAL _____
 REFER TO CH00-0250-016
 FINISH _____
 REFER TO CH00-0250-016
 ANGLE _____
 ORDER NUMBER (TABLE 1) _____
 ENTRY SIZE (TABLE 2) _____
 BAND TERMINATION CONFIGURATION (3)(8) _____
 V - ONE STEP STANDARD BAND
 W - ONE STEP MICROBAND
 U - TWO STEP STANDARD BAND
 FOR BNX, LEAVE BLANK
 OPTION FIELD SEPARATOR _____
 MODIFICATION CODE _____
 REFER TO CH00-0250-016 (2)

NOTES:

1. THIS PRODUCT IS DESIGNED TO TERMINATE A BRAIDED CABLE SHIELD BY MEANS OF A BAND STRAP AND A HEAT SHRINKABLE LIPPED BOOT TO A CONNECTOR.

(2) FOR ADDITIONAL DIMENSIONS, ORDERING INFORMATION AND MODIFICATIONS, SEE CH00-0250-016.

(3) SEE DRAWING BND-XXXXX FOR MORE INFORMATION.



4. BACKSHELL TO BE PERMANENTLY MARKED WITH CODE IDENTIFICATION NUMBER AND FULL BASIC PART NUMBER (e.g. 06090-BND40AB00-1814). BACKSHELL TO BE MARKED WITH "BND" EVEN IF NO BAND IS ORDERED. THE BAND TERMINATION CONFIGURATION CODE IS FOR ORDERING INFORMATION ONLY AND IS NOT A PART MARKING REQUIREMENT.

(5) ALL ENTRY SIZES ARE SHOWN IN TABLE 2. MAXIMUM ENTRY SIZES ARE SHOWN IN TABLE 1. IF MAX ENTRY IS EXCEEDED, A 2 PIECE BACKSHELL ASSEMBLY (TYPE 2) IS SUPPLIED. SEE CH00-0250-016 FOR FURTHER DETAILS.

6. BACKSHELL MATES TO MIL-DTL-38999, SERIES III AND IV, CLASS C, F, K, AND W, D38999/20, /24, /26, /40, /46 AND /47 CONNECTORS, AND WHEN SO MATED SHALL PROVIDE A WATER-TIGHT SEAL MEETING THE REQUIREMENTS OF MIL-C-85049, PARA. 3. 5. 7.

(7) THESE DIMENSIONS APPLY IF A SELF-LOCKING COUPLING NUT IS USED

(8) V AND U BANDS ARE SUITABLE FOR ENTRY SIZES 03-24, W IS SUITABLE FOR ENTRY SIZES 03-12 ONLY. CONTACT FACTORY FOR BAND OPTIONS ON LARGER ENTRY SIZES.

DRAWN	K.WINCZURA	DATE	01/12/2014	 3RD ANGLE PROJECTION NOT TO SCALE UNLESS OTHERWISE SPECIFIED ALL DIMENSIONS IN MILLIMETRES GENERAL TOL LINEAR +/-0.25MM ANGULAR +/- 1°	TITLE:	BANDING BACKSHELL	 Polanco 	
CHECKED		DATE	01/12/2014					ASSY USED ON:
APPROVED	K.SHEPPARD	DATE	08/12/2014					
APPROVED	H.SMITH	DATE	10/08/2015					
REVISIONS								
LTR	DESCRIPTION	DATE	APPROVED					
F	REVISED PER ECO-15-010973	10/08/2015	H.SMITH					
G	REVISED PER ECO-15-016545	17/11/2015	H.SMITH					
TE CAGE CODE: 06090 POLAMCO/TE CAGE CODE: U5792				TE CONNECTIVITY - POLAMCO LTD RESERVES THE RIGHT TO AMEND THIS DRAWING AND THE INFORMATION SET FORTH HEREON AT ANY TIME. USERS SHOULD INDEPENDENTLY EVALUATE THE SUITABILITY OF THE PRODUCT FOR THEIR APPLICATION.		DRAWING NO: BND40	DRAWING REV: G	SHT 1

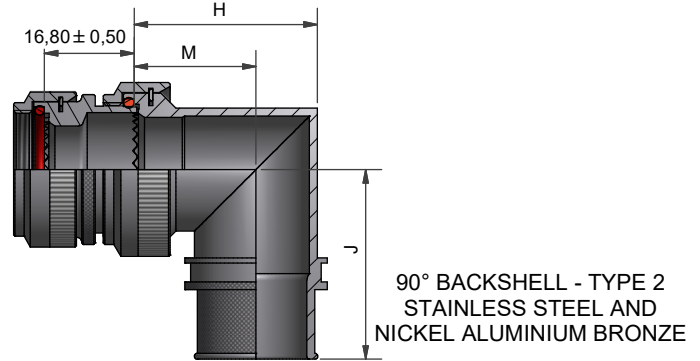
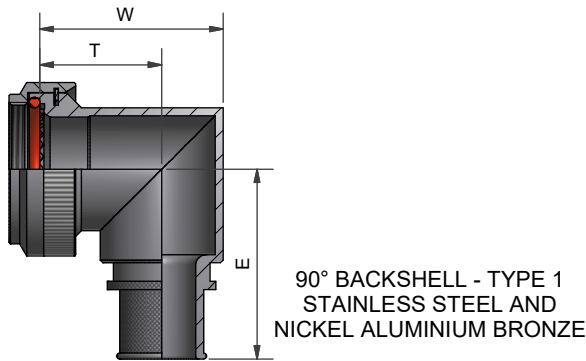
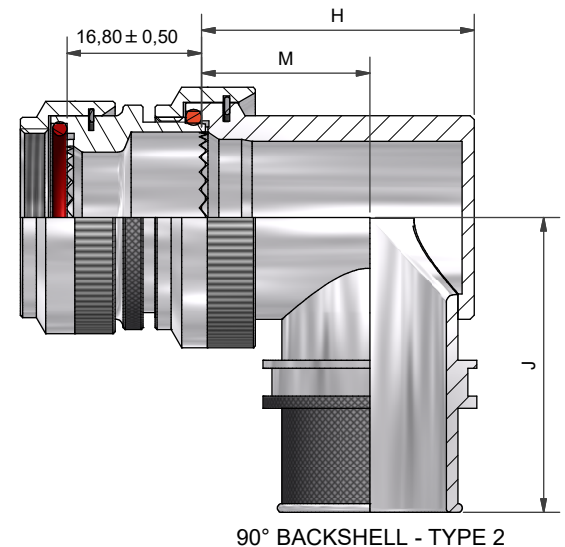
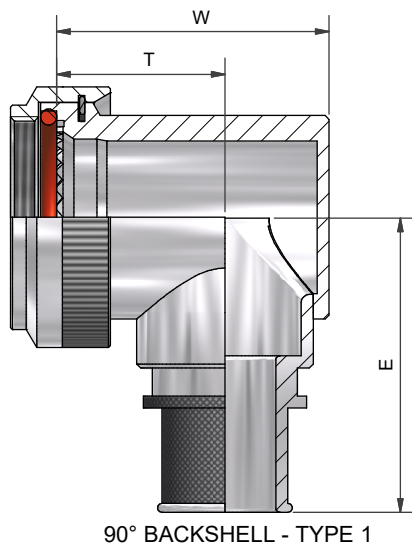
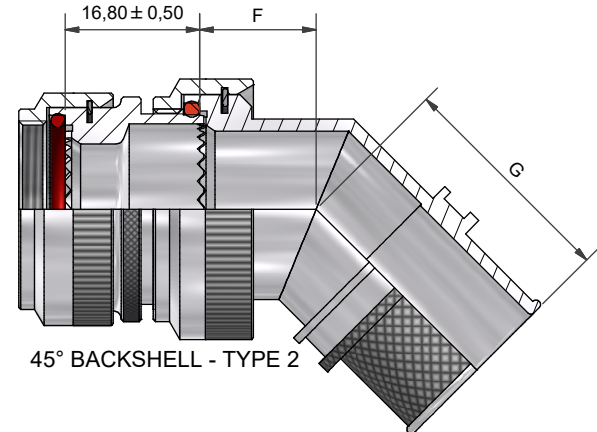
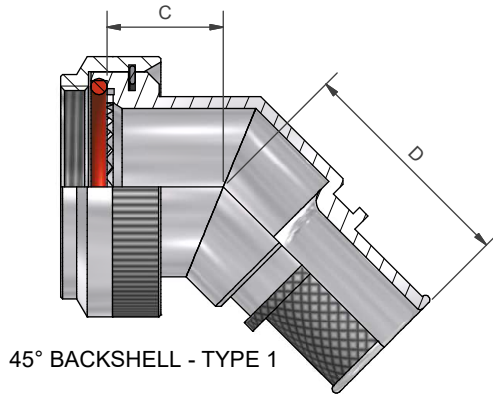
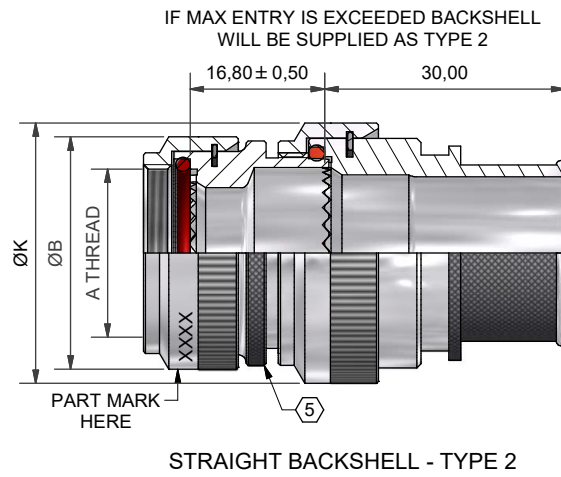
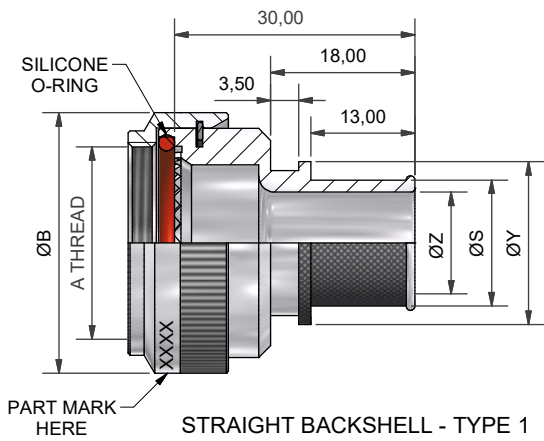

DRAWN	K.WINCZURA	DATE	01/12/2014
CHECKED		DATE	01/12/2014
APPROVED	K.SHEPPARD	DATE	08/12/2014
APPROVED	H.SMITH	DATE	10/08/2015

3RD ANGLE PROJECTION NOT TO SCALE

UNLESS OTHERWISE SPECIFIED ALL DIMENSIONS IN MILLIMETRES

GENERAL TOL
LINEAR +/-0.25MM
ANGULAR +/- 1°

TITLE:

BANDING BACKSHELL

ASSY USED ON:

MIL-DTL-38999 SERIES III & IV



REVISIONS			
LTR	DESCRIPTION	DATE	APPROVED
F	REVISED PER ECO-15-010973	10/08/2015	H.SMITH
G	REVISED PER ECO-15-016545	17/11/2015	H.SMITH

TE CAGE CODE: 06090
POLAMCO/TE CAGE CODE: U5792

TE CONNECTIVITY - POLAMCO LTD RESERVES THE RIGHT TO AMEND THIS DRAWING AND THE INFORMATION SET FORTH HEREON AT ANY TIME. USERS SHOULD INDEPENDENTLY EVALUATE THE SUITABILITY OF THE PRODUCT FOR THEIR APPLICATION.			
DRAWING NO:	DRAWING REV:	SHT	
BND40	G	2	

MODIFICATION S (SELF-LOCKING COUPLING NUT)

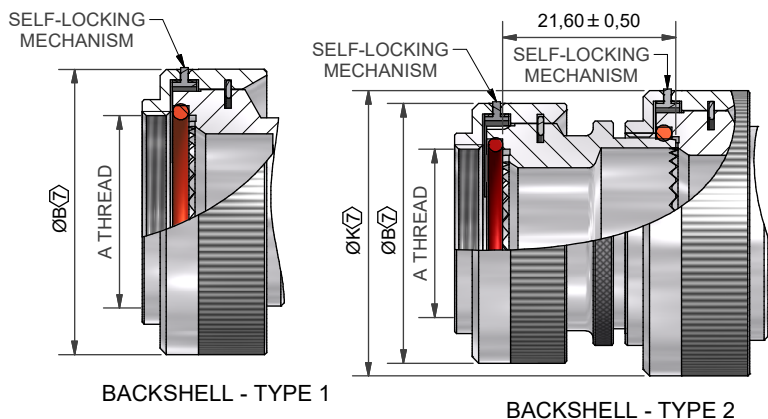

TABLE 1

ORDER NUMBER	SHELL SIZE COM'L / MIL	A THREAD	ØB MAX	ØB MAX (7)	MAX ENTRY	C ±0,5	D ±0,5	W ±0,5	T ±0,5	E ±0,5	THESE DIMENSIONS APPLY IF BACKSHELL IS STAINLESS STEEL OR NICKEL ALUMINIUM BRONZE		
											W ±0,5	T ±0,5	E ±0,5
08	9 / A	M12 × 1.0	18,0	21,5	04	12,0	25,1	21,0	14,0	30,0	21,2	16,3	29,0
10	11 / B	M15 × 1.0	21,0	24,6	07	12,5	26,2	24,0	15,5	32,0	24,3	17,2	31,2
12	13 / C	M18 × 1.0	24,5	28,3	09	13,1	26,6	27,0	17,0	33,5	28,3	19,4	33,0
14	15 / D	M22 × 1.0	29,0	32,4	10	13,5	27,5	31,0	19,5	35,4	31,1	21,0	34,9
16	17 / E	M25 × 1.0	32,5	35,6	12	14,5	28,3	34,0	21,0	36,7	34,2	22,8	35,5
18	19 / F	M28 × 1.0	35,5	38,5	14	15,5	28,8	35,0	20,0	38,3	38,5	25,3	37,2
20	21 / G	M31 × 1.0	37,0	41,7	16	16,1	29,7	38,0	21,5	40,0	40,7	26,1	38,7
22	23 / H	M34 × 1.0	40,0	43,9	18	16,5	30,0	42,0	24,0	41,6	43,7	27,6	40,2
24	25 / J	M37 × 1.0	43,5	47,0	20	17,0	30,9	45,0	25,5	43,0	46,4	29,1	44,9

TABLE 2

ENTRY SIZE	ØZ MIN	ØS MAX	ØY MAX	ØK MAX	ØK MAX (7)	F ±0,5	G ±0,5	H ±0,5	M ±0,5	J ±0,5	THESE DIMENSIONS APPLY IF BACKSHELL IS STAINLESS STEEL OR NICKEL ALUMINIUM BRONZE		
											H ±0,5	M ±0,5	J ±0,5
03	4,7	7,8	14,0	NA	NA	NA	NA	NA	NA	NA	NA	NA	NA
04	6,3	9,4	14,0	NA	NA	NA	NA	NA	NA	NA	NA	NA	NA
05	7,9	11,0	15,5	21,0	24,6	12,5	26,2	24,0	15,5	32,0	24,3	17,2	31,2
06	9,5	12,5	17,2	21,0	24,6	12,5	26,2	24,0	15,5	32,0	24,3	17,2	31,2
07	11,1	14,1	18,7	21,0	24,6	12,5	26,2	24,0	15,5	32,0	24,3	17,2	31,2
08	12,7	15,7	20,3	24,5	28,3	13,1	26,6	27,0	17,0	33,5	28,3	19,4	33,0
09	14,2	17,3	21,9	24,5	28,3	13,1	26,6	27,0	17,0	33,5	28,3	19,4	33,0
10	15,8	18,8	23,5	29,0	32,4	13,5	27,5	31,0	19,5	35,4	31,1	21,0	34,9
11	17,4	20,5	25,1	32,5	35,6	14,5	28,3	34,0	21,0	36,7	34,2	22,8	35,5
12	19,0	22,0	26,7	32,5	35,6	14,5	28,3	34,0	21,0	36,7	34,2	22,8	35,5
13	20,6	23,6	28,3	35,5	38,5	15,5	28,8	35,0	20,0	38,3	38,5	25,3	37,2
14	22,2	25,2	29,9	35,5	38,5	15,5	28,8	35,0	20,0	38,3	38,5	25,3	37,2
15	23,8	26,8	31,5	37,0	41,7	16,1	29,7	38,0	21,5	40,0	40,7	26,1	38,7
16	25,4	28,4	33,1	37,0	41,7	16,1	29,7	38,0	21,5	40,0	40,7	26,1	38,7
18	28,6	30,0	36,3	40,0	43,9	16,5	30,0	42,0	24,0	41,6	43,7	27,6	40,2
20	31,8	34,8	39,5	43,5	47,0	17,0	30,9	45,0	25,5	43,0	46,4	29,1	44,9
22	35,0	38,0	42,7	48,5	50,0	18,5	31,3	54,5	31,0	45,1	50,0	31,0	45,1
24	38,1	41,1	45,9	52,1	56,0	21,9	32,8	58,0	33,0	51,1	53,5	33,0	51,1
26 (8)	41,3	44,3	49,1	56,6	61,3	25,7	32,8	62,5	35,0	51,1	58,0	35,0	51,1
28 (8)	44,5	47,5	52,3	63,0	64,5	26,9	33,8	65,5	34,5	54,1	61,0	34,5	54,1
30 (8)	47,6	50,7	55,6	75,5	80,2	29,2	34,4	69,0	36,0	57,4	64,5	36,0	57,4
32 (8)	50,8	53,8	58,5	75,5	80,2	29,2	34,4	72,0	37,5	57,4	67,5	37,5	57,4
34 (8)	54,0	57,0	61,8	75,5	80,2	29,2	34,4	75,5	39,0	57,4	71,0	39,0	57,4

DRAWN	K.WINCZURA	DATE	01/12/2014	<p>3RD ANGLE PROJECTION NOT TO SCALE</p> <p>UNLESS OTHERWISE SPECIFIED ALL DIMENSIONS IN MILLIMETRES</p> <p>GENERAL TOL LINEAR +/-0,25MM ANGULAR +/- 1°</p>
CHECKED		DATE	01/12/2014	
APPROVED	K.SHEPPARD	DATE	08/12/2014	
APPROVED	H.SMITH	DATE	10/08/2015	
REVISIONS				
LTR	DESCRIPTION	DATE	APPROVED	
F	REVISED PER ECO-15-010973	10/08/2015	H.SMITH	
G	REVISED PER ECO-15-016545	17/11/2015	H.SMITH	
TE CAGE CODE: 06090 POLAMCO/TE CAGE CODE: U5792				

TITLE:		BANDING BACKSHELL		
ASSY USED ON:		MIL-DTL-38999 SERIES III & IV		
TE CONNECTIVITY - POLAMCO LTD RESERVES THE RIGHT TO AMEND THIS DRAWING AND THE INFORMATION SET FORTH HEREON AT ANY TIME. USERS SHOULD INDEPENDENTLY EVALUATE THE SUITABILITY OF THE PRODUCT FOR THEIR APPLICATION.				
DRAWING NO:		DRAWING REV:		SHT
BND40		G		3



Mouser Electronics

Authorized Distributor

Click to View Pricing, Inventory, Delivery & Lifecycle Information:

[TE Connectivity:](#)

[CV0609-000](#)