

THIS DRAWING IS UNPUBLISHED. RELEASED FOR PUBLICATION 20
 © COPYRIGHT 20 BY - ALL RIGHTS RESERVED.

REVISIONS					
P	LTR	DESCRIPTION	DATE	DWN	APVD
F1		COLOR CODE DETAILS ADDED	09JAN2014	TJ	JK
F2		ADDITION OF NOTE 12. TEXT "REF" DIM 1.9 & 2.42 IN ZONE C1 & C2. DIM 29.4 CHANGED TO "29.4 MAX" IN ZONE B3	21JULY2015	TJ	PS
F3		PN 164159-5 DISCONTINUED	19DEC2017	TJ	NG
F4		REVISED PER ECO-18-010674	06JUL2018	RS	MZ

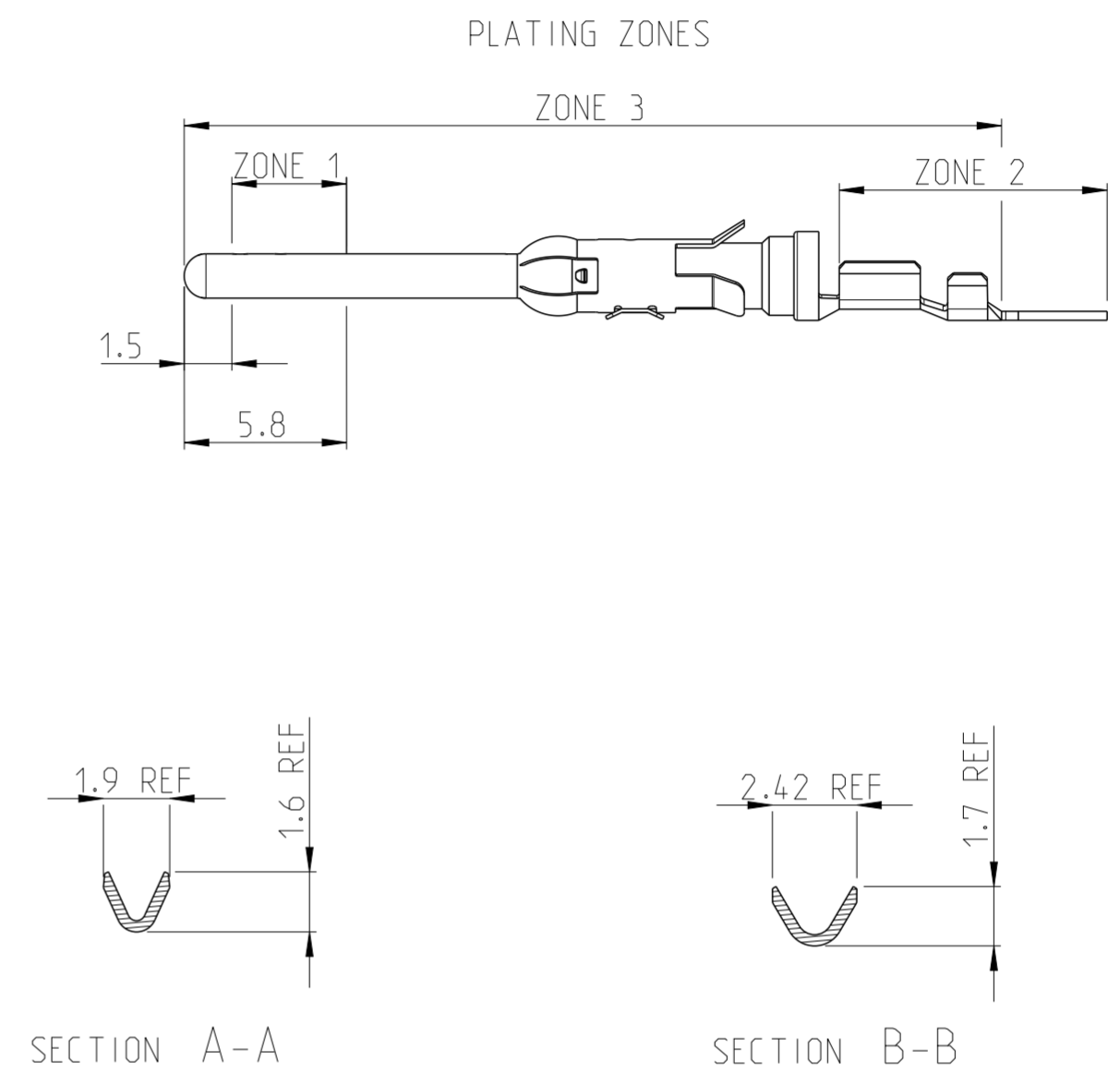
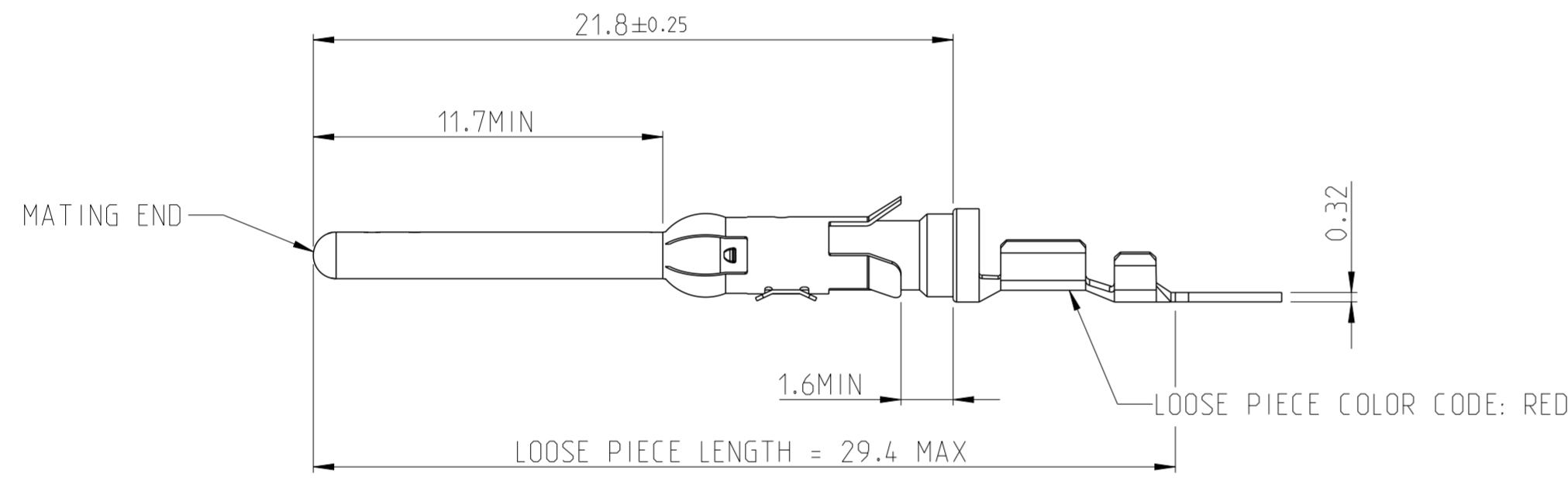
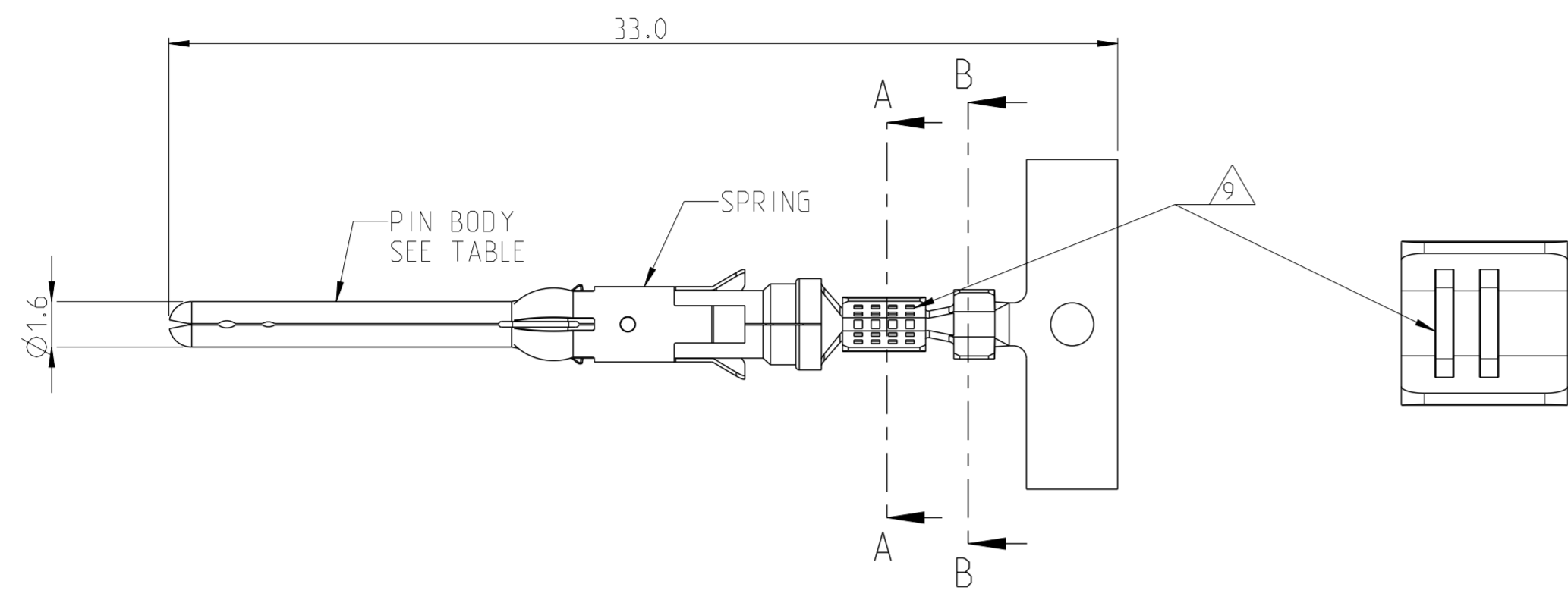

- 1 1.27 MICRON MIN NICKEL PLATE OVER ZONE 3.
0.76 MICRON MIN PRECIOUS METAL PLATE OVER ZONE 1.
1 MICRON MIN TIN PLATE OVER ZONE 2.
CONFORMS TO THE REQUIREMENTS OF TE CONNECTIVITY PRODUCT SPEC 108-10042
BASED ON EIA/ECA-364-1000.01A (CONTROLLED ENVIRONMENT APPLICATIONS)
- 2 1.27 MICRONS MIN NICKEL PLATE OVER ZONE 3.
0.76 MICRON MIN PRECIOUS METAL ELECTROPLATE OVER ZONE 1.
0.076 MICRON MIN GOLD FLASH PLATE OVER THE REMAINDER OF ZONE 3.
CONFORMS TO THE REQUIREMENTS OF TE CONNECTIVITY PRODUCT SPEC 108-10042
BASED ON EIA/ECA-364-1000.01A (CONTROLLED ENVIRONMENT APPLICATIONS)
- 3 1.54 - 2.54 MICRON SILVER PLATE OVER ZONE 3.
- 4 1.27 MICRON MIN NICKEL PLATE OVER ZONE 3.
0.76 MICRON MIN GOLD PLATE OVER ZONE 1.
0.076 MICRON MIN GOLDFLASH PLATE OVER THE REMAINDER OF ZONE 3.
- 5 1.27 MICRON MIN NICKEL PLATE OVER ZONE 3.
0.76 MICRON MIN GOLD PLATE OVER ZONE 1.
1 MICRON MIN TIN PLATE OVER ZONE 2.
- 6 HOT-DIPPED PRETIN
- 7 1.27 MICRONS MIN NICKEL PLATE OVER ZONE 3.
1 - 3 MICRON ELECTRO-TIN PLATE OVER ZONE 3
- 8 0.76 MICRON MIN NICKEL PLATE OVER ZONE 3 PER QQ-N-290
1.5 - 2.54 MICRON SILVER PLATE OVER ZONE 3,
- 9 SERRATIONS CAN BE MULTILOCK OR TWO SLOTS.
- 10. WIRE RANGE: 0.12-0.20 mm² (26-24 AWG)
- 11. INSULATION RANGE: 0.9-1.4 mm (.035-.055) DIA
- 12. OMISSION OF 6 CONTACTS MAX PER REEL OF 5000PCS

A	1	STAINLESS STEEL	BRASS	164162-4	164159-7
B	1	STAINLESS STEEL	BRASS		164159-6
A	2	STAINLESS STEEL	BRASS		164159-4
A	7	STAINLESS STEEL	BRASS		164159-3
B	2	STAINLESS STEEL	BRASS	164162-2	164159-2
B	7	STAINLESS STEEL	BRASS	164162-1	164159-1
REELING	FINISH	SPRING MATERIAL	PIN BODY	LOOSE PIECE	PART NO

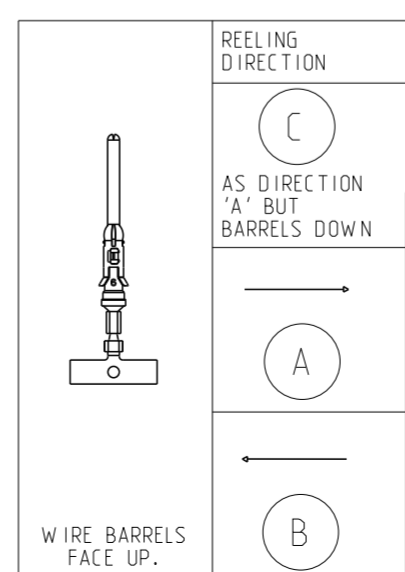

THIS DRAWING IS A CONTROLLED DOCUMENT.

DIMENSIONS: mm

TOLERANCES UNLESS OTHERWISE SPECIFIED:
 0 PLC ±0.5
 1 PLC ±0.25
 2 PLC ±0.15
 3 PLC ±0.15
 4 PLC ±
 ANGLES ±2°
 FINISH SEE TABLE

MATERIAL SEE TABLE

APVD: M.GREENER 01JUN2012
 CHK: J.BRIGHT 01JUN2012
 APVD: D.PENNINGTON 01JUN2012

PRODUCT SPEC: 108-10042
 APPLICATION SPEC: 114-19000

NAME: TYPE III+, SIZE 16, PIN ASS'Y, LONG SERIES, 26-24 AWG, 0.9-1.4mm DIA INSULATION

SIZE: A2 CAGE CODE: 100779 DRAWING NO: C-164159

SCALE: 10:1 SHEET: 1 OF 1 REV: F4

Mouser Electronics

Authorized Distributor

Click to View Pricing, Inventory, Delivery & Lifecycle Information:

[TE Connectivity:](#)

[164162-2](#)