

THIS DRAWING IS UNPUBLISHED. RELEASED FOR PUBLICATION  
 © COPYRIGHT - By - ALL RIGHTS RESERVED.

LOC		DIST		REVISIONS			
P	LTR	DESCRIPTION		DATE	DWN	APVD	
	E	UPDATE PER ECO-14-000182		6 JAN 14	GS	CAS	

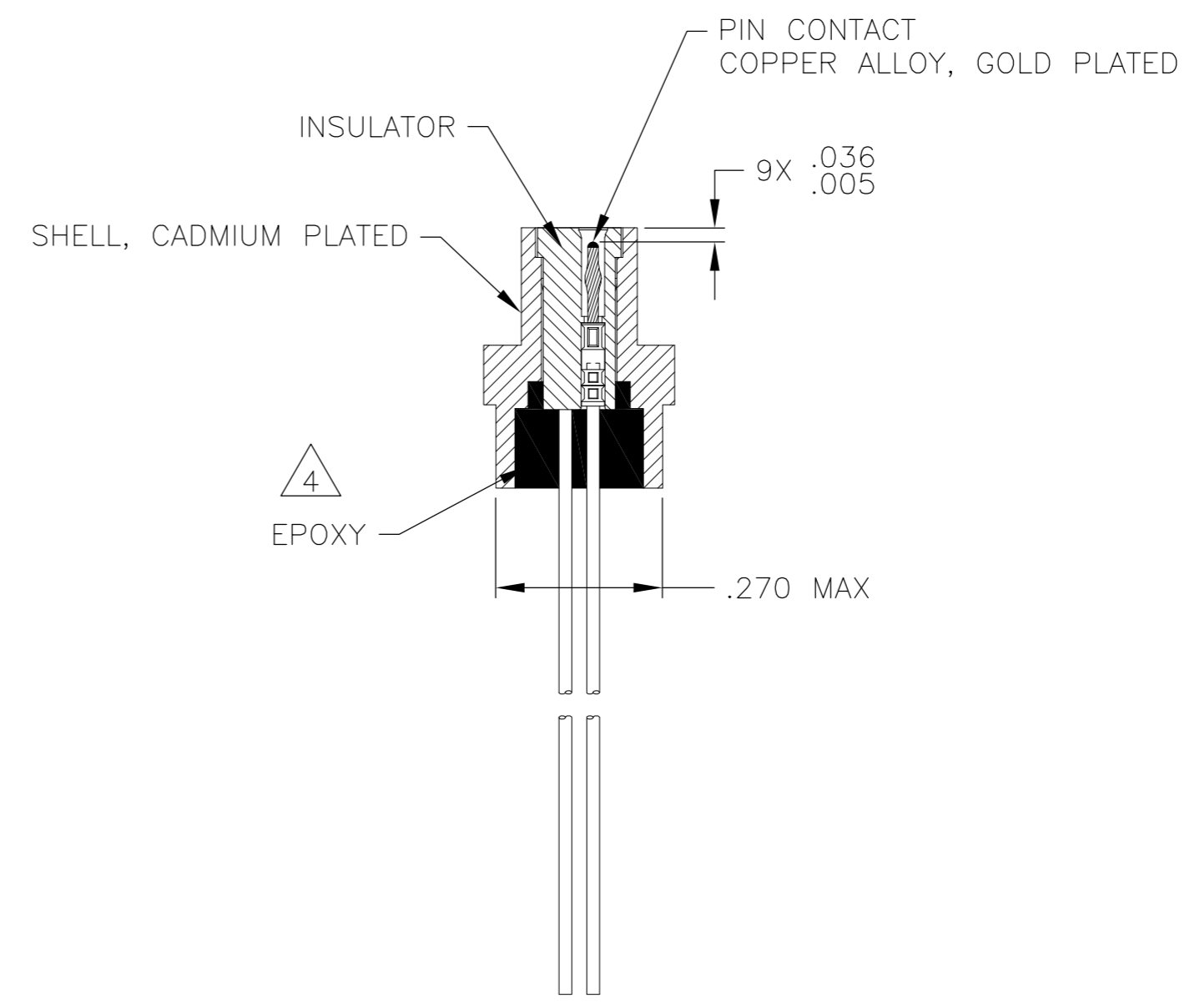
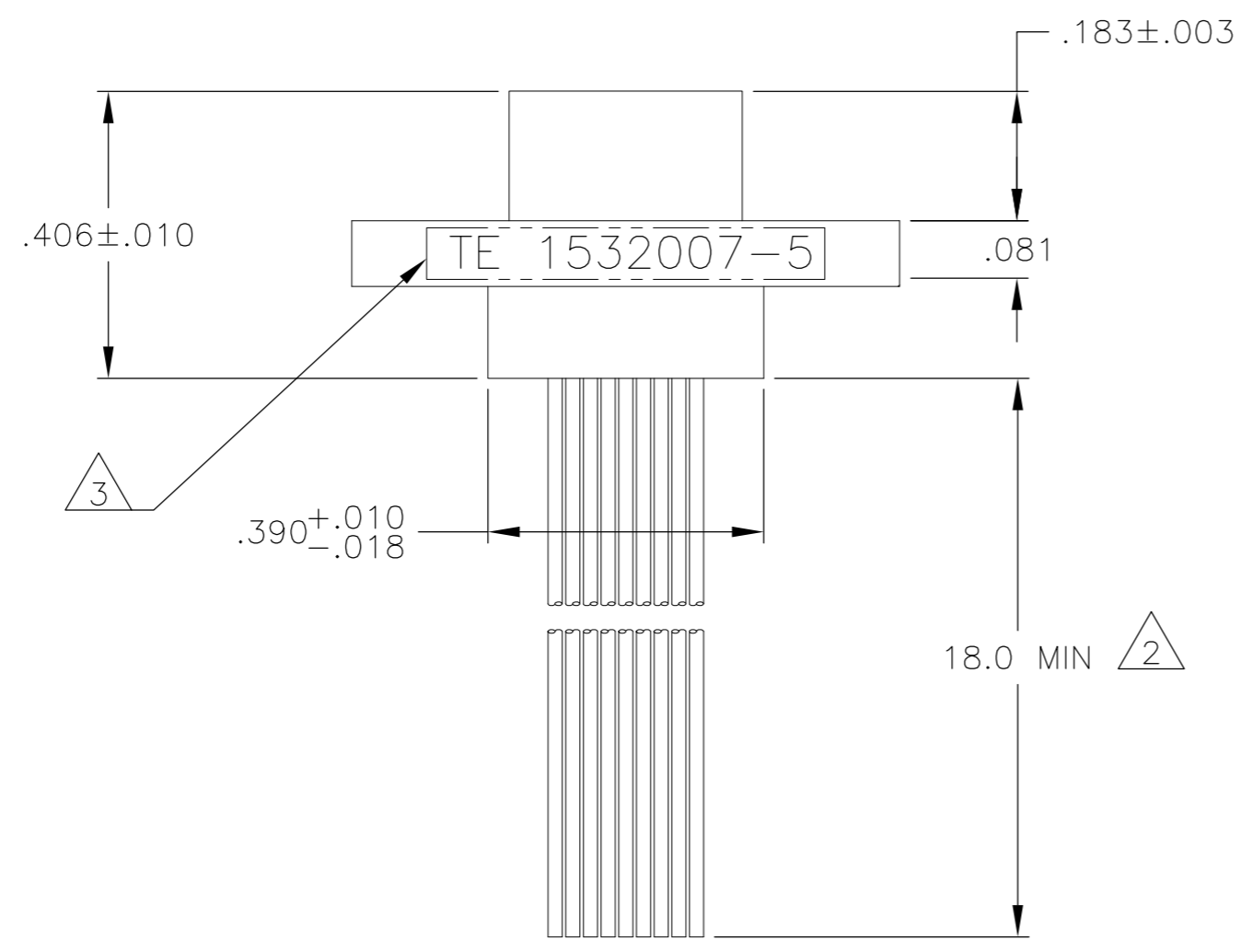
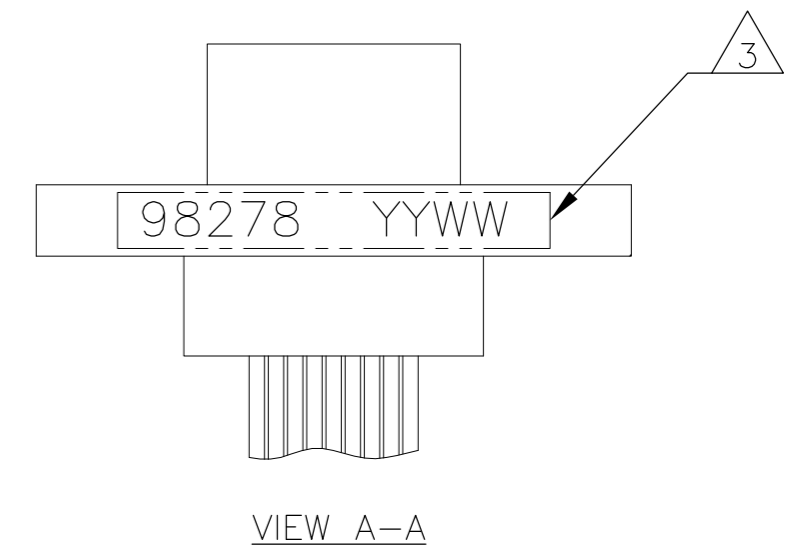
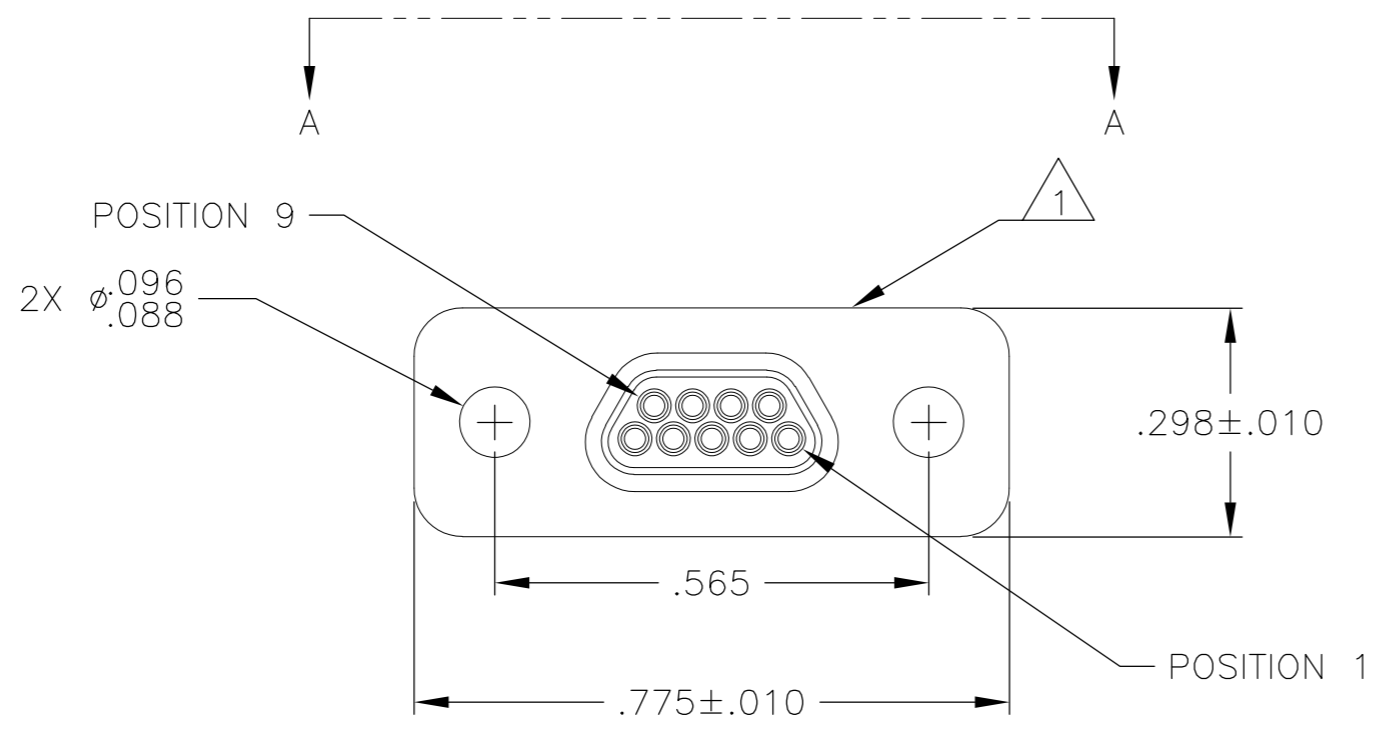

- 1 SHELL MATERIAL: 6061-T6 ALUMINUM, CADMIUM PLATE PER SAE-AMS-QQ-P-416.
- 2 INSULATOR MATERIAL: RYTON, POLYPHENYLENE SULFIDE (PPS), COLOR BLACK, PER ASTM D406
- 3 THIS CONFIGURATION TO BE TERMINATED WITH 26AWG, 7/34 COLOR CODED PER MEP 217-00, CODE 00.
- 4 MARK PER MEP203-12, CODES B, C, D AND E AS SHOWN
- 5 EPOXY ENCAPSULATION. EPOXY MAY WICK .125 INCH MAX

THIS DRAWING IS A CONTROLLED DOCUMENT.		DWN	23 FEB 94									
DIMENSIONS: INCHES		CHK	CAMPOS									
TOLERANCES UNLESS OTHERWISE SPECIFIED:		APVD	-									
0 PLC ± -		PRODUCT SPEC	-									
1 PLC ± -		APPLICATION SPEC	-									
2 PLC ± .005		WEIGHT	-									
3 PLC ± .010		CUSTOMER DRAWING	SCALE 3:1 SHEET 1 OF 1 REV E									
4 PLC ± -		MATERIAL SEE NOTES FINISH SEE NOTES										
ANGLES ± 2°		<table border="1"> <tr> <th>SIZE</th> <th>CAGE CODE</th> <th>DRAWING NO</th> <th>RESTRICTED TO</th> </tr> <tr> <td>A2</td> <td>98278</td> <td>1532007-5</td> <td>-</td> </tr> </table>			SIZE	CAGE CODE	DRAWING NO	RESTRICTED TO	A2	98278	1532007-5	-
SIZE	CAGE CODE	DRAWING NO	RESTRICTED TO									
A2	98278	1532007-5	-									

# Mouser Electronics

Authorized Distributor

Click to View Pricing, Inventory, Delivery & Lifecycle Information:

[TE Connectivity:](#)

[1532007-5](#)