

PART NUMBER	REV	FIRST USED	POWER UNIT	FEED TYPE
466779-3	AB	854400-1	LEADMAKER	AIRFEED
466779-4	AB	565435-5	BENCH MODEL K	AIRFEED
466779-5	AB	843083-1	LEADMAKER	DOUBLE-ACTING AIRFEED
466779-6	AB	354500-1	BENCH MODEL G	AIRFEED
7-466779-7	U	-	SPARE TOOLING KIT	-

- 1 RECOMMENDED SPARE PARTS.
- 2 GREASE LIGHTLY.
- 3 GUARD MUST BE IN PLACE WHEN OPERATING APPLICATOR IN A BENCH MACHINE.
- 4 SEE DRAWING FOR COMPONENTS.
- 5 TO CHECK CRIMP HEIGHT, CRIMP SOLDER (Ø .12 60/40 SOLID CORE) AND MEASURE AT CENTER OF SLUG.

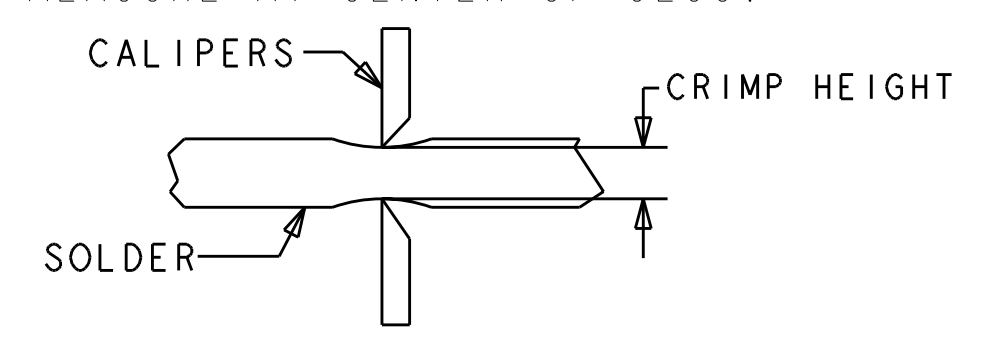

- 6 CUT TO LENGTH AT ASSEMBLY.
- 7 ITEM 16 MUST BE REMOVED IF APPLICATOR IS REMOVED FROM LEADMAKER AND PLACED IN AMP-O-LECTRIC* TERMINATING UNIT.
- 8 ITEM 76 REQUIRED WHEN APPLICATOR IS REMOVED FROM LEADMAKER AND PLACED IN AMP-O-LECTRIC* TERMINATING UNIT.
- 9 INSTALL ITEM 75 IN CHIP RELIEF HOLE OF T-TERMINATOR UNIT BEFORE INSTALLING APPLICATOR.
- 10 REMOVE WIRE FUNNEL WHEN USING THIS APPLICATOR ON AMPOMATOR* FEED SIDE T-TERMINATOR UNIT.
- 11 IT MAY BE NECESSARY TO MODIFY THE T-TERMINATING UNIT'S BASE PLATE BEFORE INSTALLING THIS APPLICATOR BY ADDING A 10-32 HOLE TO RELOCATE THE FORWARD STOP AS SHOWN.

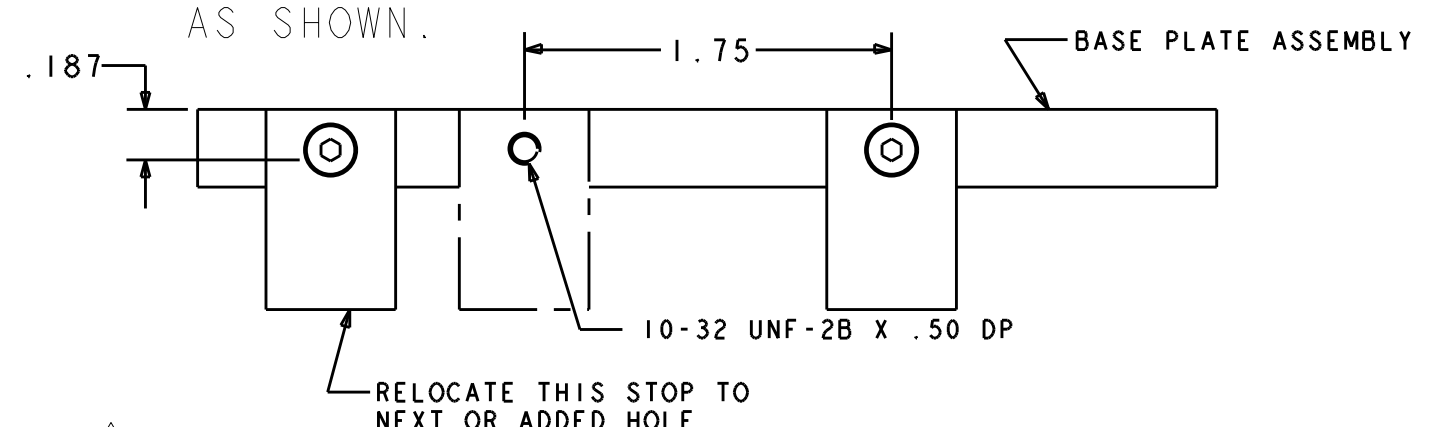

- 12 GROUP I: Ø .135 MAX INSULATION
- 13 GROUP II: Ø .200 MAX INSULATION.
- 14 USE ITEMS 5 & 9 WITH GROUP I. USE ITEMS 20 & 10 WITH GROUP II.
- 15 USE ITEM 21 WITH GROUP I. USE ITEM 22 WITH GROUP II.
- 16 ITEMS 75 AND 77 MUST BE INSTALLED IN THE G-TERMINATING UNIT CHIP RELIEF HOLE BEFORE INSTALLING THE APPLICATOR.
- 17 ITEM NOT SHOWN.

GROUP I		GROUP II		AMP TERMINAL - AMP CRIMP SPECS		
520102	520261					
520181	520263	PAD LTR		CRIMP HEIGHT	WIRE SIZE	Ø SOLDER
520183	520274	A		.070±.002	18 OR (2)22 OR (1)20 + (1)22	Ø .12
520193	521144	B		.065±.002	22 OR 20	Ø .12
520302	-	C		-	-	-
521102	-	D		-	-	-
521104	-		CRIMP	SIZE	TYPE	RANGE
521308	-					
-	-		WIRE	.176	D	22-18
-	-		INSUL	-	-	-
521406	-					
WIRE STRIP LENGTH .265-.291	TERM APPL SPEC 114-2123	FEED .785-.940	APPL INSTRUCTIONS 408-8051	SET UP GAGE 458637-1	LAYOUT 1040	

-	1	1	1	1	-	4-21028-0	PIN, SLOTTED SPRING .094 X .750	121
-	3	3	3	3	-	21024-5	WASHER, SPRG LOCK, REG NO 10	117
-	4	4	4	4	-	21024-2	WASHER, SPRG LOCK, REG NO 4	114
-	1	1	1	1	-	21024-8	WASHER, SPRG LOCK, REG 3/8	112
-	4	4	4	4	-	21024-4	WASHER, SPRG LOCK, REG NO 8	111
-	1	1	1	1	-	22353-8	SCR, SHLD, SLOT HD, 3/16 DIA	105
-	1	1	1	1	-	21009-2	SCR, SET, SELF LOCKING 1/4-20 X .250	103
-	2	2	2	2	-	21017-2	SCREW, DRIVE	102
-	1	1	1	1	-	461264-1	PLATE, IDENTIFICATION	100
-	2	2	2	2	-	5-21006-6	SCR, SET, CUP POINT 10-32 X .750	99
-	1	1	1	1	-	22733-8	SCR, BHSC, SELF-LOCKING, 8-32 X .375	98
-	REF	REF	REF	REF	-	2-21002-9	SCR, BTN SKT HD CAP 10-32 X .750	97
-	REF	REF	REF	REF	-	2-22733-8	SCR, BHSC, SELF-LOCKING, 1/4-20 X .625	96
-	1	1	1	1	-	2-21002-7	SCR, BTN SKT HD CAP 10-32 X .500	95
-	4	4	4	4	-	2-21002-2	SCR, BTN SKT HD CAP 8-32 X .500	94
-	2	6	2	6	-	1-21000-4	SCR, SKT HD CAP 4-40 X .375	93
-	-	2	-	2	-	1-21002-7	SCR, BTN SKT HD CAP 6-32 X .375	92
-	2	2	2	2	-	3-21000-0	SCR, SKT HD CAP 8-32 X .875	87
-	1	1	1	1	-	2-22603-1	SCREW, MACH, HEX HD, 8-32 X .375	86
-	6	4	6	4	-	1-21000-3	SCR, SKT HD CAP 4-40 X .250	85
-	1	1	1	1	-	2-21000-7	SCR, SKT HD CAP 8-32 X .500	84
-	1	1	1	1	-	3-21000-4	SCR, SKT HD CAP 10-32 X .375	81
-	-	1	-	1	-	1-18023-1	SCR, SHC, M4x10	80
-	-	REF	1	-	-	462992-5	GUARD ASSY	79
-	REF	-	-	-	-	679532-1	INSERT, GUARD	78
-	-	1	-	1	-	189728-1	BRACKET, SPACER	77
-	-	-	1	-	-	803931-1	BRACKET, HOLD DOWN	76
-	-	1	-	1	-	568681-1	SPACER, BASE PLATE	75
-	1	1	1	1	-	690603-1	SPRING ASSIST AMP-O-MATOR APPLICATOR	74
-	1	1	1	1	-	23030-1	SCR, SKT HD CAP, S-LOCK, 6-32 X .25	73
-	1	1	1	1	-	3-21001-5	SCR, SKT HD CAP 3/8-16 X 1.000	72
-	1	1	1	1	-	459610-3	MOUNT, FEED BRACKET	71
-	-	-	1	-	-	692655-5	AIR FEED VALVE ASSEMBLY	69
-	-	1	-	-	-	461065-4	AIR FEED ASSY	68
-	-	-	REF	-	-	24042-2	VALVE, SHUT-OFF	67
-	-	-	REF	-	-	692655-6	AIR FEED VALVE ASSEMBLY	66

LOC	DIST	REV	DATE	BY	APPD
A	66	Z1	19JAN2007	WEAVER	
		AA	18JUL2007	ELBIN	
		AB	16OCT2007	ELBIN	
		ABI	08JUL2009	ELBIN	

ITEM NO	DESCRIPTION	ITEM NO
65	ASSEMBLY, AIR FEED	65
64	SCR, SKT HD CAP 10-32 X 1.000	64
63	ELBOW, SWIVEL, 1/8 NPT-1/4 T	63
62	INSERT, COUPLING	62
61	TUBING 1/4" O.D.	61
60	AIR FEED VALVE ASSEMBLY	60
59	CAP, RAM	59
58	HOUSING, APPL CSTG	58
56	FINGER, FEED	56
53	FEED FINGER ASSEMBLY	53
49	PLATE, REAR SHEAR	49
48	HOLDER, SHEAR	48
47	APPLICATOR, BASIC SUBASSEMBLY	47
46	APPLICATOR, BASIC SUBASSEMBLY	46
45	PLUG, NYLON	45
44	RAM, SIDE FEED	44
43	SHIM SUB-ASSY	43
42	WASHER, RAM (.115)	42
41	CRIMPER, BOLT SPECIAL	41
40	BALL, STEEL	40
39	SPRING, COMPRESSION	39
38	DISC, SPRING	38
37	WIRE DISC	37
36	SPRING, COMPRESSION	36
35	POST, RAM	35
34	PLATE, BASE	34
33	PLATE, BASE	33
32	ADJUSTMENT SCREW	32
31	WASHER, WAVE SPRING	31
30	BLOCK, STRIP GUIDE ADJUST	30
29	PLATE, STRIP GUIDE	29
27	SPRING, COMPRESSION	27
26	LEVER, DRAG RELEASE	26
25	DRAG, TERMINAL	25
24	FRONT STRIP GUIDE	24
23	GUIDE, STRIP, FRONT	23
22	SUPPORT, INSULATION	22
21	SUPPORT, INSULATION	21
20	FUNNEL, WIRE	20
19	STRIPPER	19
18	HOLD DOWN, TERMINAL	18
17	SPRING, COMPRESSION	17
16	GUIDE, CARRIER SCRAP	16
15	PLATE, REAR SHEAR	15
14	HOLDER, SHEAR, REAR	14
13	REAR FLOATING SHEAR	13
12	SPRING, COMPRESSION	12
11	STOP, SHEAR	11
10	TERMINAL SUPPORT	10
9	TERMINAL SUPPORT	9
8	ANVIL, SAND-BLASTED 22-18	8
7	SPACER	7
6	DEPRESSOR SHEAR, REAR	6
5	WIRE FUNNEL	5
4	BLOCK, FL CRIMPER SPACER	4
3	STABILIZER	3
2	SPACER	2
1	CRIMPER, SEMI-FLAT 22-18	1
-77	U/M PART NO	

TRADEMARK - *

DIMENSIONS: IN		TOLERANCES UNLESS OTHERWISE SPECIFIED:		DWG NO: 19JAN2007		DATE: 19JAN2007		BY: WEAVER		APPD: T. ELBIN	
9 PLC ±		3 PLC ±		19JAN2007		DATE: 19JAN2007		BY: WEAVER		APPD: T. ELBIN	
5 PLC ±		2 PLC ±		19JAN2007		DATE: 19JAN2007		BY: WEAVER		APPD: T. ELBIN	
4 PLC ±		1.5 PLC ±		19JAN2007		DATE: 19JAN2007		BY: WEAVER		APPD: T. ELBIN	
ANGLES ±		FINISH ±		19JAN2007		DATE: 19JAN2007		BY: WEAVER		APPD: T. ELBIN	
MATERIAL		FINISH		19JAN2007		DATE: 19JAN2007		BY: WEAVER		APPD: T. ELBIN	
CUSTOMER DRAWING		SCALE: 1:2		SHEET 1 OF 2		REV: ABI		Tjco Electronics		Tyco Electronics Harrisburg, PA 17105-3608	
CUSTOMER DRAWING		SCALE: 1:2		SHEET 1 OF 2		REV: ABI		Tjco Electronics		Tyco Electronics Harrisburg, PA 17105-3608	

CUSTOMER VIEWABLE ASSEMBLY

LOC		DIST		REVISIONS			
A	66	P	LTR	DESCRIPTION	DATE	OWN	APVD
		-	-	SEE SHEET 1			

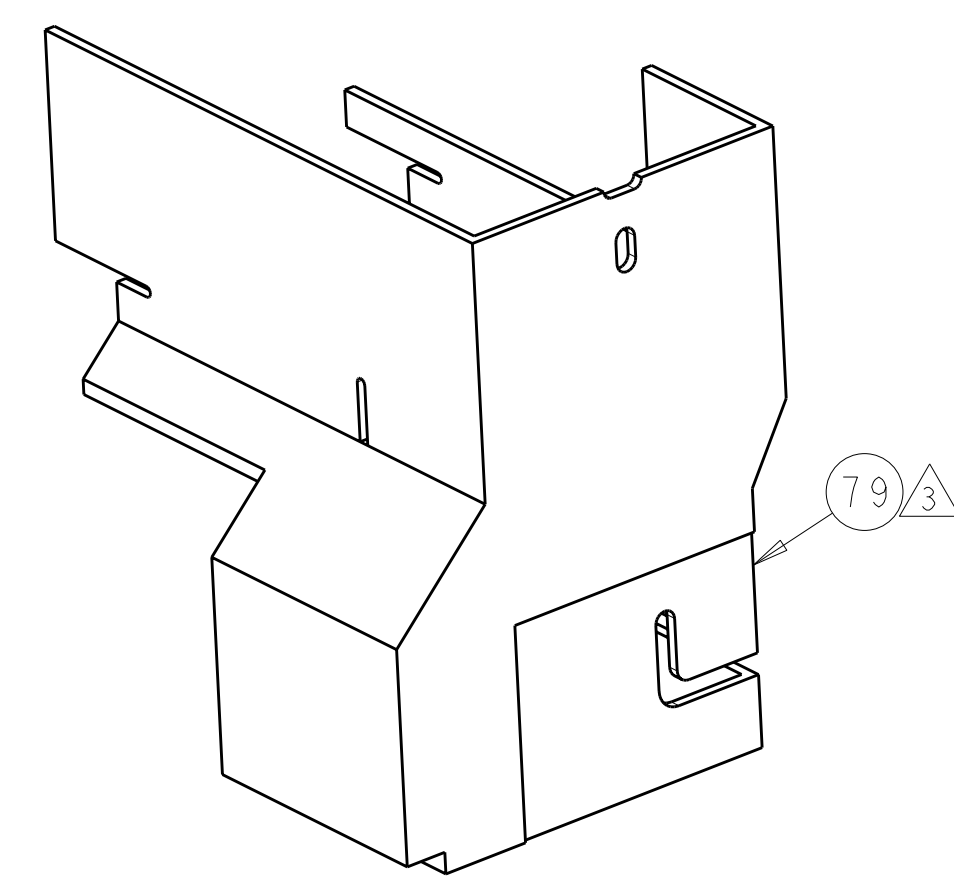
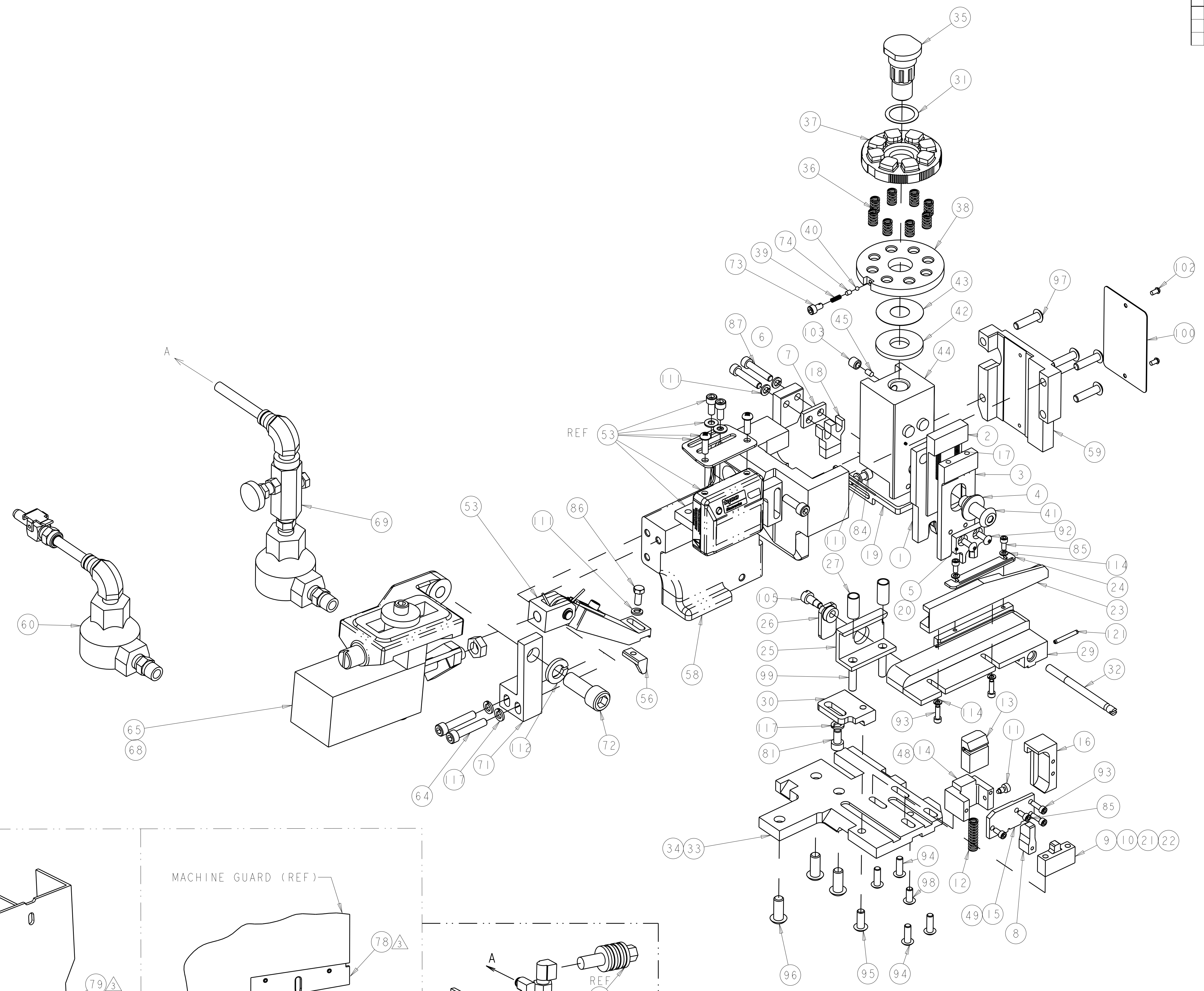

AMP-O-LECTRIC* TERMINATOR GUARD

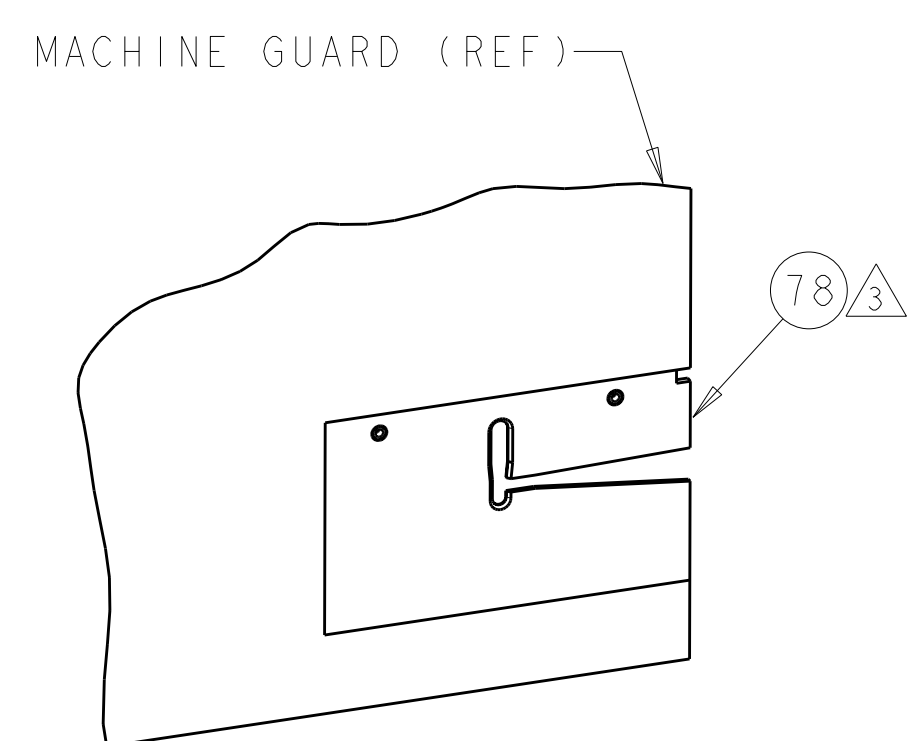

G TERMINATOR GUARD

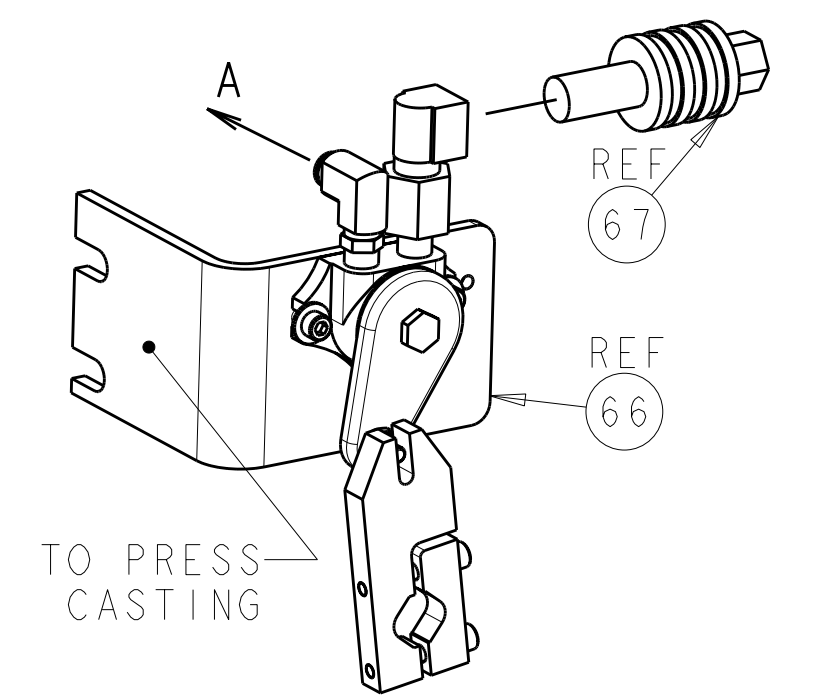

TO PRESS CASTING

<small>THIS DRAWING IS UNPUBLISHED. RELEASED FOR PUBLICATION 2007. ALL RIGHTS RESERVED. THIS IS SUBJECT TO CHANGE WITHOUT NOTICE. THE USER SHALL BE RESPONSIBLE FOR OBTAINING THE LATEST REVISIONS. CONTACT THE DRAWING OFFICE FOR THE LATEST REVISIONS.</small>		DWN: B. WEAVER 19JAN2007 CHK: T. ELBIN 19JAN2007 APVD: T. ELBIN 19JAN2007	tyco Electronics Tyco Electronics Harrisburg, PA 17105-3608
DIMENSIONS: IN 		TOLERANCES UNLESS OTHERWISE SPECIFIED: 9 PLC ± 1 PLC ± 5 PLC ± 4 PLC ± ANGLES ± FINISH:	NAME: SIDE FEED HDM APPLICATOR PRODUCT SPEC: - APPLICATION SPEC: - SIZE: CAGE CODE DRAWING NO: A1100779C-466779 WEIGHT: - CUSTOMER DRAWING:
MATERIAL: - FINISH: -		SCALE: 3:4 SHEET: 2 OF 2 REV: ABI	RESTRICTED TO: -

Mouser Electronics

Authorized Distributor

Click to View Pricing, Inventory, Delivery & Lifecycle Information:

[TE Connectivity:](#)

[7-466779-7](#)