

PART NUMBER	REV	FIRST USED
466090-1	L	122500-1
466090-2	L	565435-5

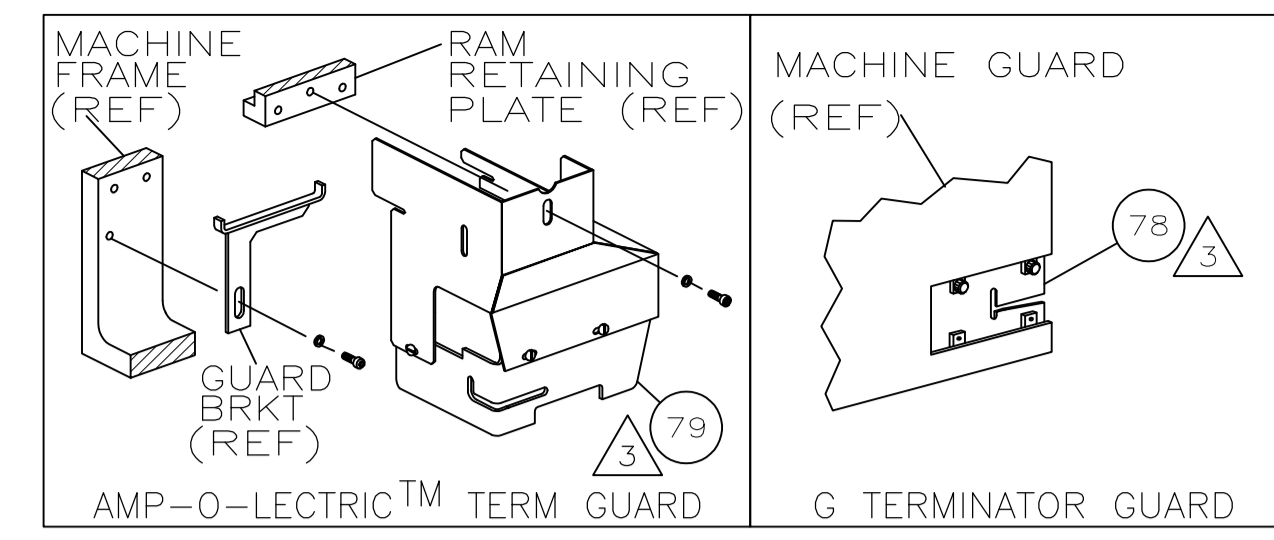

TERMINAL NAME: FASTON™ RECEPTACLE		CRIMPING DATA	
61818	63837	CRIMP HEIGHT	WIRE SIZE
63924	1742656	A .031 ±.002 [0.79 ±0.05mm]	22 OR (2)26
1217198		B .028 ±.002 [0.71 ±0.05mm]	24
		C .027 ±.002 [0.69 ±0.05mm]	26
		D NOT USED	
		CRIMP SIZE	TYPE RANGE
		WIRE .055 [1.4mm]	F 26-22
		INSUL -	-
WIRE STRIP LENGTH	TERM APPL SPEC	FEED	APPL INSTRUCTION
.141-.171	114-2036	.397	408-8039
			SET UP GAGE
			458638-1
			LAYOUT
			414

LOC	DIST	REVISIONS			
A	66	F LTR	DESCRIPTION	DATE	BY
		L	ECR-09-015272	7-2009	MY

-1	LEADMAKER & BENCH MODEL G	MECH POST FEED
-2	BENCH MODEL K	MECH PRE FEED

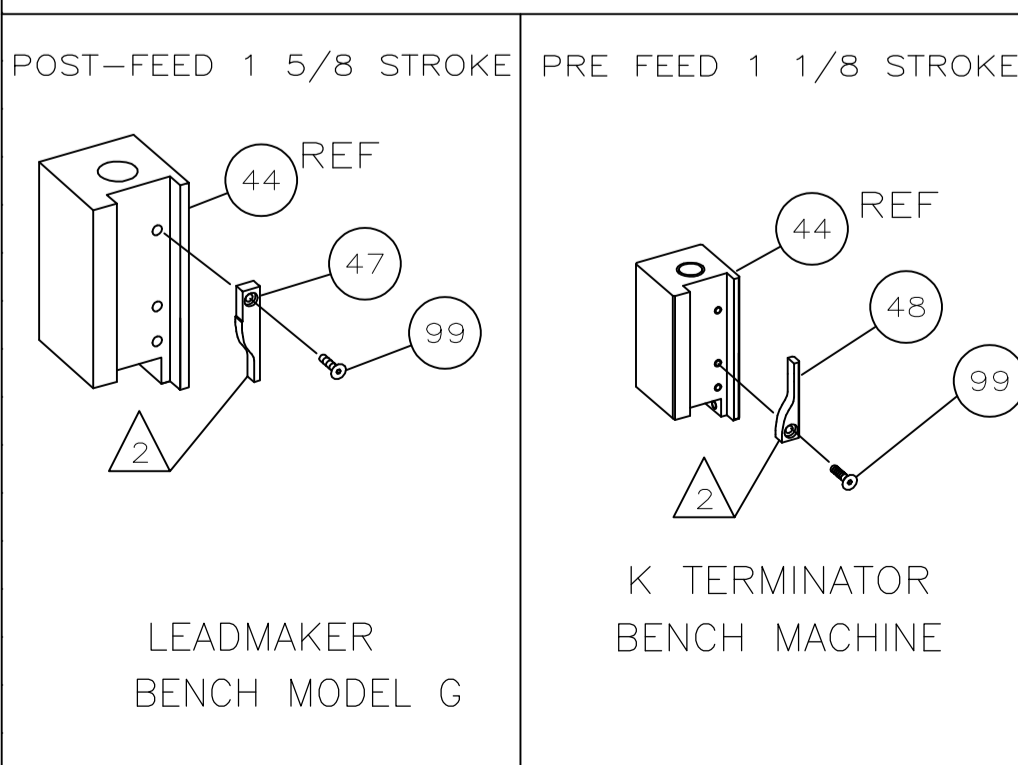
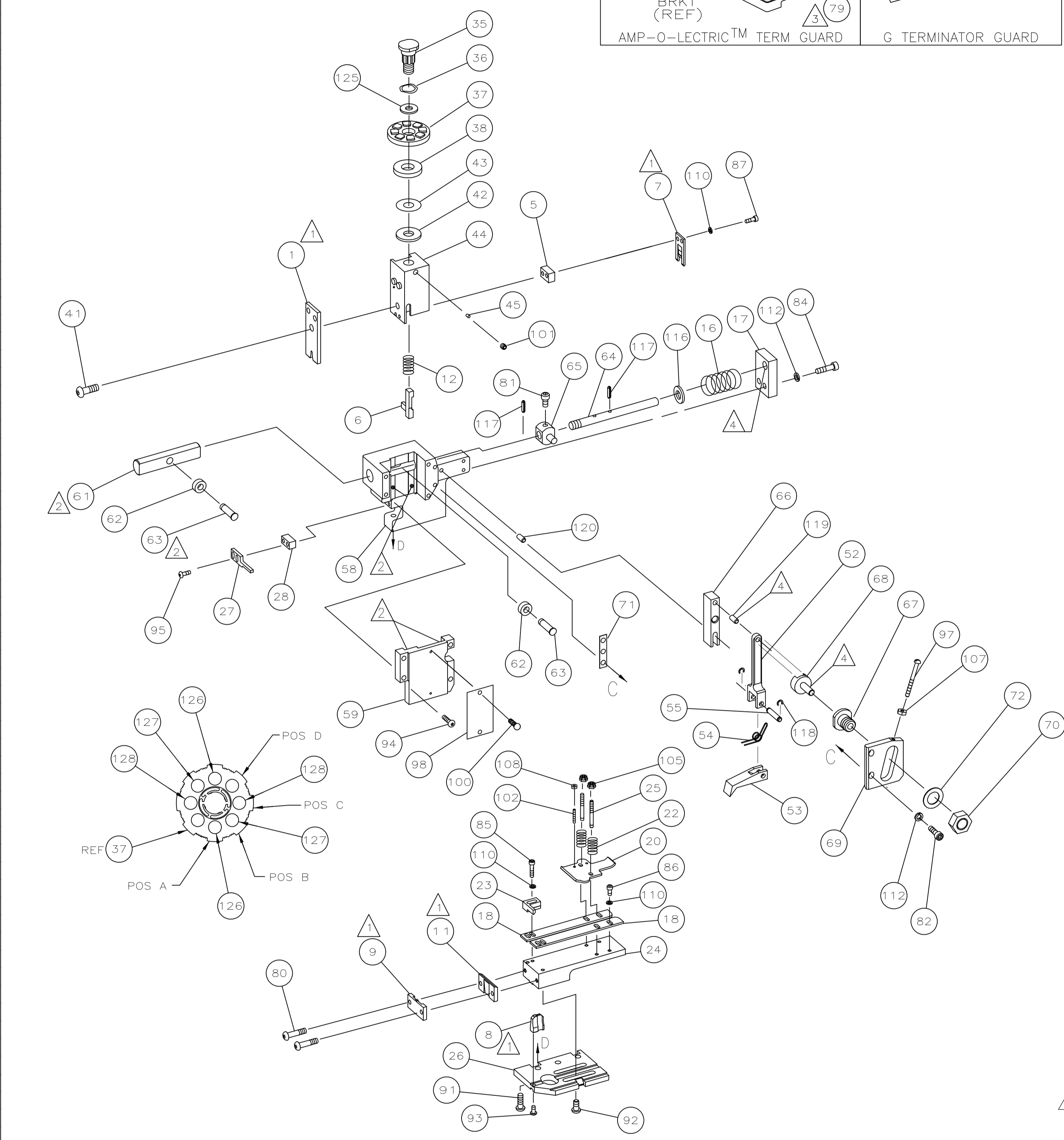

- 1 RECOMMENDED SPARE PARTS.
- 2 GREASE LIGHTLY.
- 3 GUARD MUST BE IN PLACE WHEN OPERATING APPLICATOR IN A BENCH MACHINE.
- 4 LUBRICATE DAILY USING NO. 20 MACHINE OIL.
- 5 ITEMS WITH QTY OF REF SPECIFIED (EXCEPT ITEMS 78 AND 79) ARE USED ON ITEM 32.
- 6 ITEM 78 USED WITH G TERMINATOR ONLY.
- 7 SET UP APPLICATOR TO FEED OFF OF RECEPTACLE END OF TERMINAL.

QTY	REF	QTY	REF	DESCRIPTION	ITEM NO
2	2	-	6-354779-8	PIN, WIRE DISC (.3330)C	129
2	2	-	6-354779-6	PIN, WIRE DISC (.3320)B	127
2	2	-	6-354779-0	PIN, WIRE DISC (.3290)A	126
1	1	-	986950-1	WASHER, FLAT PRECISION	125
1	1	-	217238-1	GENERAL INSTRUCTION PACKAGE	124
1	1	-	4088039	EF APPL INST 408-8039	123
					122
					121
REF	REF	-	1-21030-7	PIN, DOWEL (Ø.187x1.50)HSG	120
REF	REF	-	1-21030-1	PIN, DOWEL (Ø.187x.50)LEVER	119
REF	REF	-	21045-3	RING, RET "C" (Ø.187)FD PIN	118
REF	REF	-	5-21028-1	PIN, STD SPRING (Ø.12)FD ADJ ROD	117
REF	REF	-	21899-4	WASHER, FLAT (Ø5/16)SCR ADJ	116
					115
					114
					113
REF	REF	-	21024-5	WASHER, LOCK (NO.10)FD ROD GDE	112
					111
7	7	-	21024-4	WASHER, LOCK (NO.8)SHEAR BL	110
					109
2	2	-	21018-4	NUT, HEX (4-40)DRAG	108
REF	REF	-	21018-5	NUT, HEX (6-32)FD ADJ PL	107
					106
2	2	-	21022-2	NUT, HEX SL (8-32)DRAG STUD	105
					104
					103
2	2	-	2-21006-6	SCR, SKT SET (4-40x.62)DRAG	102
1	1	-	21009-2	SCR, SKT SET (1/4-20x.25 )RAM	101
2	2	-	21017-2	SCR, DRIVE (#2x.19)ID PLATE	100
1	1	-	1-21002-7	SCR, BHC (6-32x.38)CAM	99
1	1	-	461264-1	PLATE, IDENTIFICATION	98
REF	REF	-	6-23715-5	SCR, PAN HD (6-32x1.50)FEED ADJ	97
					96
2	2	-	2-21002-2	SCR, BHC (8-32x.50)STRIPPER	95
REF	REF	-	2-21002-9	SCR, BHC (10-32x.75)HSG CAP	94
1	1	-	22733-8	SCR, BHC (8-32x.38 LW)ANVIL	93
4	4	-	3-21002-3	SCR, BHC (1/4-20x.50)ST GD PL	92
REF	REF	-	2-22733-8	SCR, BHC (1/4-20x.62)BASE PL	91
					90
					89
					88
2	2	-	2-21000-5	SCR, SHC (8-32x.25)SLUG BLADE	87
3	3	-	7-21000-4	SCR, SHC (8-32x.31)STRIP GUIDE	86
2	2	-	2-21000-8	SCR, SHC (8-32x.62)R STRIP GUIDE	85
REF	REF	-	3-21000-7	SCR, SHC (10-32x.75)FEED ROD GDE	84
					83
REF	REF	-	3-21000-6	SCR, SHC (10-32x.62)FEED ADJ PL	82
REF	REF	-	3-21000-4	SCR, SHC (10-32x.38)PIVOT BLOCK	81
2	2	-	3-21002-0	SCR, BHC (10-32x.88)SHEAR PL	80
REF	-	-	455745-1	GUARD, WINDOW	79
-	REF	-	679532-1	INSERT, GUARD	78
					77
					76
					75
					74
					73
					72
REF	REF	-	458109-1	WASHER, FLAT (SPECIAL)	71
REF	REF	-	690517-1	SPACER	70
					69
					68
					67
					66
					65
					64
					63
					62
					61
					60
					59
					58
					57
					56
					55
					54
					53
					52
					51
					50
					49
1	-	-	690602-5	CAM, PRE FEED 1 1/8 ST	48
-	1	-	690501-4	CAM, POST-FEED 1 5/8 ST	47
					46
1	1	-	690191-1	PLUG, NYLON	45
1	1	-	455674-2	RAM	44
1	1	-	690125-1	WASHER, LAMINATED	43
1	1	-	690124-1	WASHER, RAM	42
1	1	-	7-21002-9	BOLT, CRIMPER (5/16-24x1.00)	41
					40
					39
					38
1	1	-	690223-2	SPACER, INSULATION DISC	37
1	1	-	354777-1	WIRE DISC, PLASTIC	36
1	1	-	22480-5	WASHER, SPRING	35
1	1	-	690212-1	POST, RAM	34
					33
1	1	-	458980-1	APPLICATOR, BASIC (SUB ASSY)	32
					31
					30
					29
1	1	-	4-690451-7	SPACER, STRIPPER	28
1	1	-	240639-2	STRIPPER	27
REF	REF	-	455676-1	PLATE, BASE	26
2	2	-	22354-8	DRAG, STUD	25
1	1	-	455678-1	PLATE, STRIP GUIDE	24
1	1	-	240825-9	PLATE, STRIP HOLD DOWN	23
2	2	-	4-22281-1	SPRING, DRAG	22
					21
1	1	-	454177-1	DRAG, STOCK	20
					19
2	2	-	454204-9	GUIDE, STRIP (FRONT)	18
REF	REF	-	454178-1	GUIDE, FEED ROD	17
REF	REF	-	4-22284-9	SPRING, FEED RETURN	16
					15
					14
					13
1	1	-	5-22282-3	SPRING, HOLD DOWN	12
1	1	-	240644-1	PLATE, REAR SHEAR	11
					10
1	1	-	690482-5	PLATE, FRONT SHEAR	9
1	1	-	3-240654-2	ANVIL	8
1	1	-	690474-5	BLADE, SLUG	7
1	1	-	6-455892-5	HOLD DOWN, TERMINAL	6
1	1	-	5-240641-8	SPACER, SLUG BLADE	5
					4
					3
					2
1	1	-	1-456402-6	CRIMPER, WIRE	1

REF	REF	QTY	REF	DESCRIPTION	ITEM NO
REF	REF	-	22594-8	NUT, HEX	70
REF	REF	-	240628-1	PLATE, ADJ	69
REF	REF	-	240626-1	SHAFT, PIVOT	68
REF	REF	-	240633-1	BUSHING	67
REF	REF	-	455680-1	LEVER, INTERMEDIATE	66
REF	REF	-	240629-1	BLOCK, PIVOT	65
REF	REF	-	240632-2	SCR, ADJ	64
REF	REF	-	240659-3	PIN, CAM ROLLER	63
REF	REF	-	240658-1	CAM, ROLLER	62
REF	REF	-	454398-1	ROD, FEED	61
					60
REF	REF	-	454220-1	CAP, RAM	59
REF	REF	-	453736-1	HOUSING	58
					57
					56
REF	REF	-	240624-1	PIN, FEED FINGER	55
REF	REF	-	691499-1	SPRING, FEED FINGER	54
REF	REF	-	240635-1	FINGER, FEED	53
REF	REF	-	240634-1	LEVER, TERMINAL	52
					51
					50
					49
1	-	-	690602-5	CAM, PRE FEED 1 1/8 ST	48
-	1	-	690501-4	CAM, POST-FEED 1 5/8 ST	47
					46
1	1	-	690191-1	PLUG, NYLON	45
1	1	-	455674-2	RAM	44
1	1	-	690125-1	WASHER, LAMINATED	43
1	1	-	690124-1	WASHER, RAM	42
1	1	-	7-21002-9	BOLT, CRIMPER (5/16-24x1.00)	41
					40
					39
					38
1	1	-	690223-2	SPACER, INSULATION DISC	37
1	1	-	354777-1	WIRE DISC, PLASTIC	36
1	1	-	22480-5	WASHER, SPRING	35
1	1	-	690212-1	POST, RAM	34
					33
1	1	-	458980-1	APPLICATOR, BASIC (SUB ASSY)	32
					31
					30
					29
1	1	-	4-690451-7	SPACER, STRIPPER	28
1	1	-	240639-2	STRIPPER	27
REF	REF	-	455676-1	PLATE, BASE	26
2	2	-	22354-8	DRAG, STUD	25
1	1	-	455678-1	PLATE, STRIP GUIDE	24
1	1	-	240825-9	PLATE, STRIP HOLD DOWN	23
2	2	-	4-22281-1	SPRING, DRAG	22
					21
1	1	-	454177-1	DRAG, STOCK	20
					19
2	2	-	454204-9	GUIDE, STRIP (FRONT)	18
REF	REF	-	454178-1	GUIDE, FEED ROD	17
REF	REF	-	4-22284-9	SPRING, FEED RETURN	16
					15
					14
					13
1	1	-	5-22282-3	SPRING, HOLD DOWN	12
1	1	-	240644-1	PLATE, REAR SHEAR	11
					10
1	1	-	690482-5	PLATE, FRONT SHEAR	9
1	1	-	3-240654-2	ANVIL	8
1	1	-	690474-5	BLADE, SLUG	7
1	1	-	6-455892-5	HOLD DOWN, TERMINAL	6
1	1	-	5-240641-8	SPACER, SLUG BLADE	5
					4
					3
					2
1	1	-	1-456402-6	CRIMPER, WIRE	1

THIS DRAWING IS A CONTROLLED DOCUMENT.

APPROVED: **T. ELBIN** 7/1/96

DESIGNED: **C. FRISMAN** 7/1/96

BY: **B. HIGMAN** 7/1/96

DATE: 7/1/96

NAME: **T. ELBIN**

PRODUCT SPEC: **END FEED HDM APPLICATOR**

APPLICATION SPEC: **---**

SIZE: **A1** CASE CODE: **00779** DRAWING NO: **466090** RESTRICTED TO: **---**

MATERIAL: **---** FINISH: **---** WEIGHT: **---** SCALE: **---** SHEET: **1** OF **1** REV: **L**

CUSTOMER DRAWING

# Mouser Electronics

Authorized Distributor

Click to View Pricing, Inventory, Delivery & Lifecycle Information:

[TE Connectivity:](#)

[466090-2](#)