

LOC		DIST		REVISIONS			
P	LTR	DESCRIPTION	DATE	DN	APVD	CT	CD
K		REV PER ECO 13-014895	12-4-13				

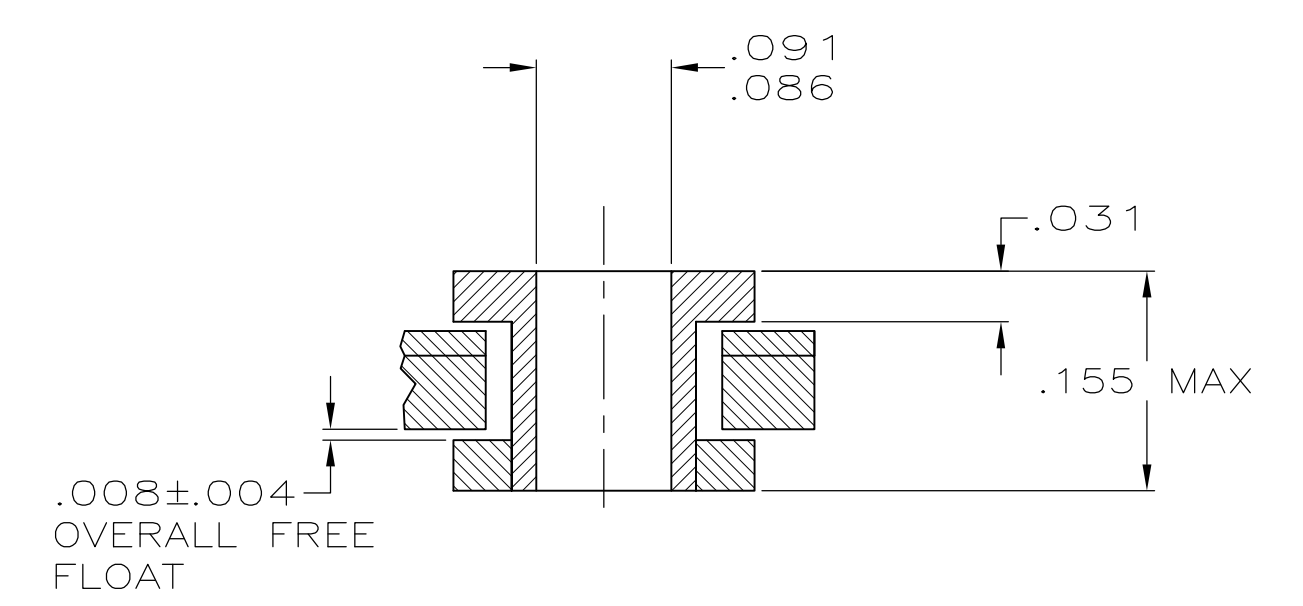
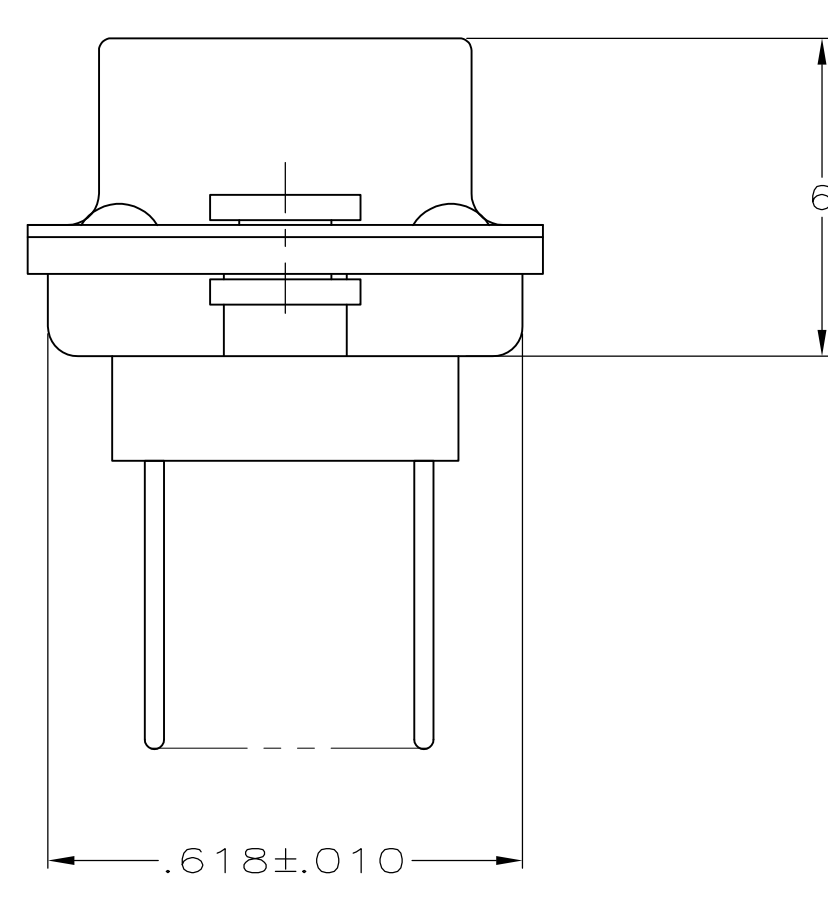
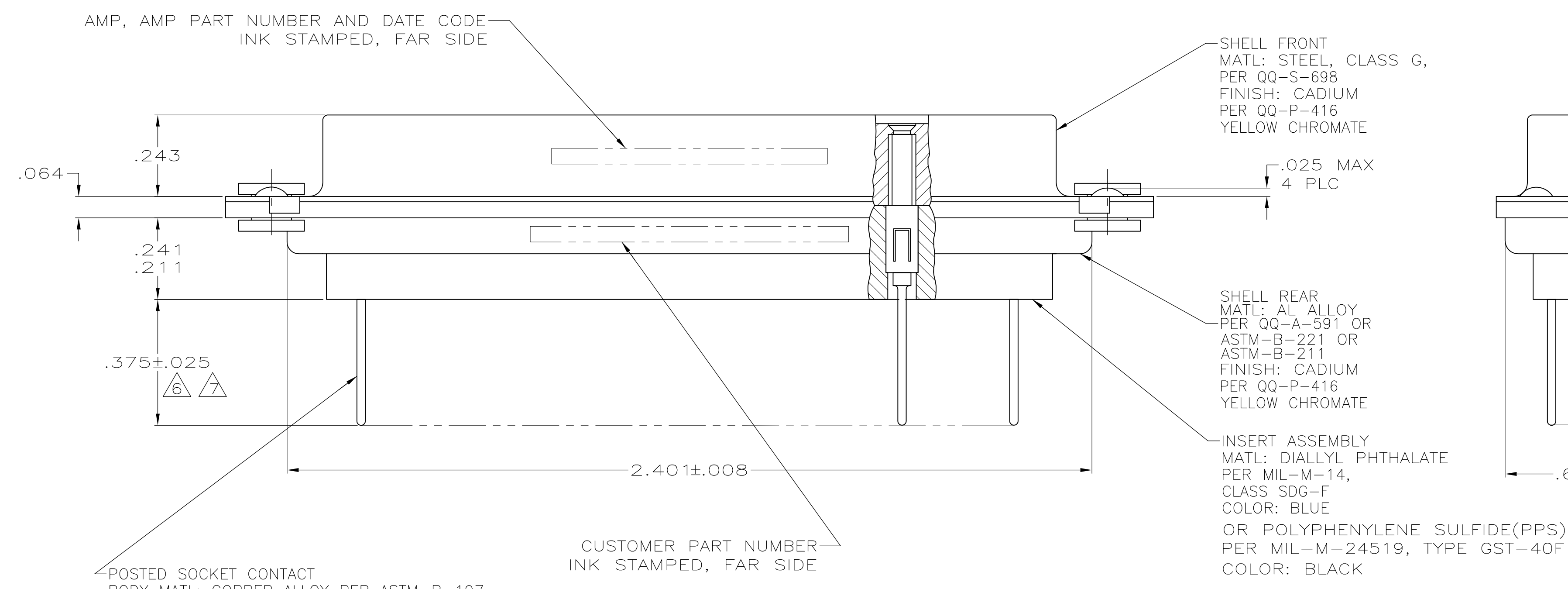
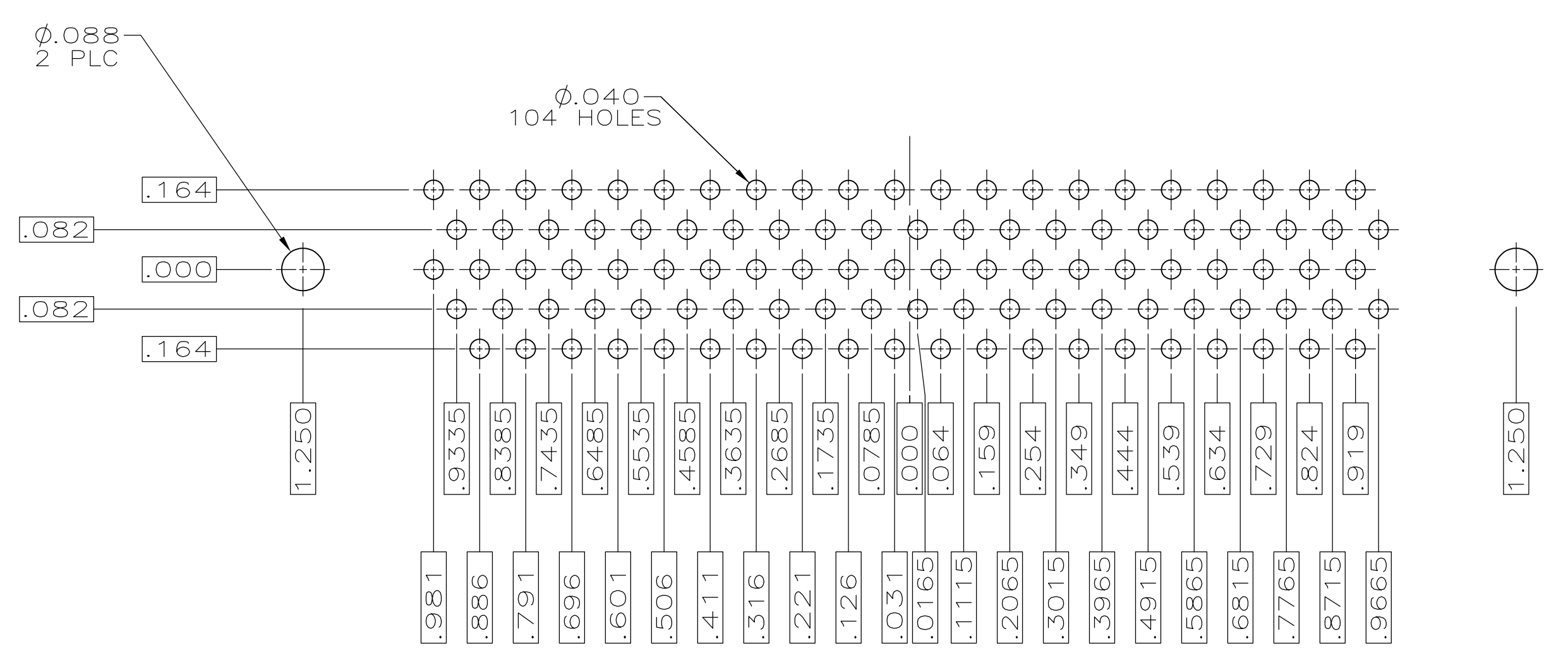
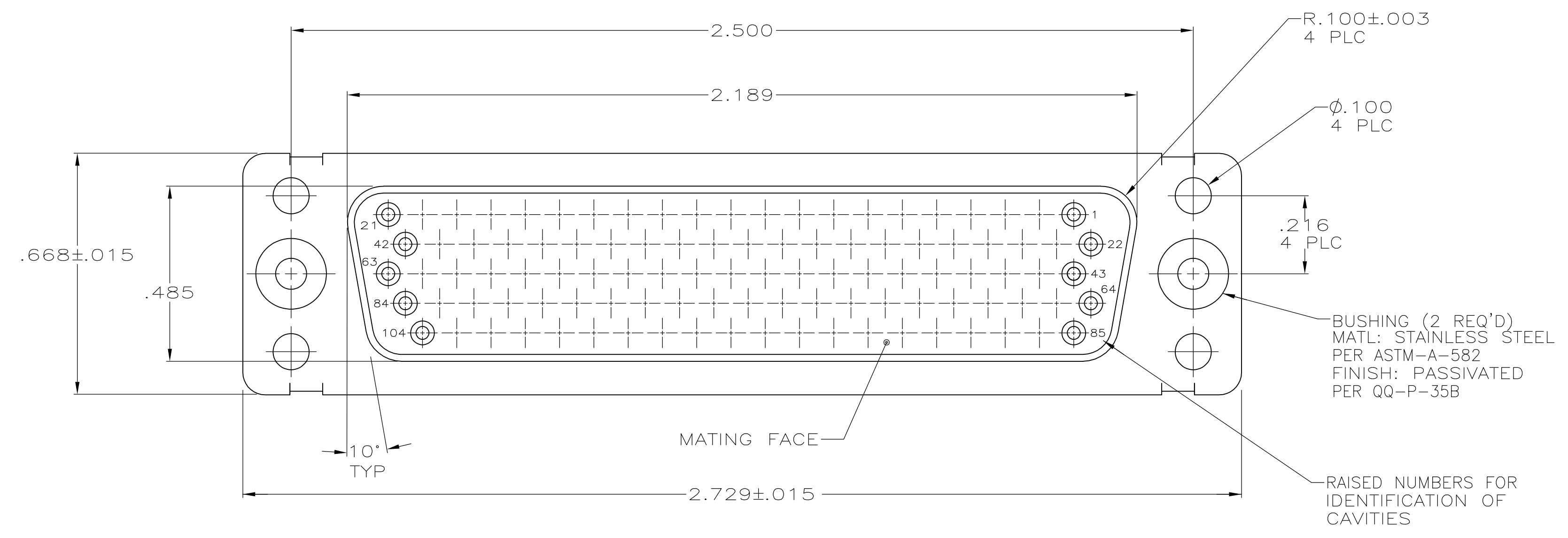

DUAL MOUNT FLOATING BUSHING
SCALE 8:1

POSTED SOCKET CONTACT
BODY MATL: COPPER ALLOY PER ASTM-B-197
BODY FINISH: GOLD PER MIL-G-45204
OVER COPPER PER MIL-C-14550
HOOD MATL: STAINLESS STEEL PER ASTM-A-167
HOOD FINISH: PASSIVATE PER ASTM-A-380

1. THIS RECEPTACLE WILL MATE WITH ANY 104 POSITION, SIZE 6 PLUG IN AMPLIMITE SERIES.
2. STAINLESS STEEL RETENTION CLIPS ARE INCLUDED IN INSERTS.
3. REPLACEMENT SOCKET CONTACT NO. 207684-7.
4. TO INSERT OR REMOVE CONTACTS USE INSERTION/EXTRACTION TOOL P/N 91067-1 OR MIL NO. M81969/1-04.

- ⚠ UL/CSA DESIGNATION STAMPED IN THIS AREA.
- ⚠ SOLDER DIP PER MIL-STD-2000 COMPOSITION Sn63 CONFORMING TO QQ-S-571. COVERAGE SHALL BE COMPLETE TO REAR INSERT.
- ⚠ DIMENSION APPLIES PRIOR TO SOLDER DIPPING. ALLOW ADDITIONAL .030 POST PROJECTION AFTER SOLDER DIPPING.

THIS DRAWING IS A CONTROLLED DOCUMENT.		DIN THOMPSON 08-11-93	
DIMENSIONS: INCHES		CHK D. MANTIONE 08-23-93	
TOLERANCES UNLESS OTHERWISE SPECIFIED:		APVD	
0 PLC	± .005	PRODUCT SPEC	
1 PLC	± .005	APPLICATION SPEC	
2 PLC	± .005	SIZE	
3 PLC	± .005	CAGE CODE	
4 PLC	± .005	DRAWING NO.	
ANGLES	± .005	RESTRICTED TO	
MATERIAL SEE CALLOUT	FINISH SEE CALLOUT	WEIGHT	—
CUSTOMER DRAWING		SCALE 4:1	SHEET 1 OF 1

AS SHOWN	213044-1
DESCRIPTION	PART NO.
STE TE Connectivity	
RECEPTACLE ASSEMBLY, AMPLIMITE 104 POSN, SIZE 6, SERIES 90 LOADED	
SIZE	A1
CAGE CODE	00779
DRAWING NO.	213044
REV	K

Mouser Electronics

Authorized Distributor

Click to View Pricing, Inventory, Delivery & Lifecycle Information:

[TE Connectivity:](#)

[213044-1](#)