

# Fiber Optic Transmitter

OPF370A



## Features:

- Low Cost 850 nm LED technology
- Electrically isolated plastic cap package
- High thermal stability
- High optical coupling efficiency to multimode fiber
- Industrial temperature range

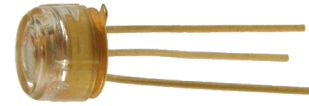

## Description:

The OPF370A fiber optic transmitter is a high performance device packaged for data communication links. This transmitter is an 850 nm GaAlAs LED and is specifically designed to efficiently launch optical power into fibers ranging in size from 50/125µm up to 200/300µm diameter fiber. Multiple power ranges with upper and lower limits are offered which allows the designer to select a device best suited for the application.

This product's combination of features including high speed and efficient coupled power makes it an ideal transmitter for integration into all types of data communications equipment.

## Applications:

- Industrial Ethernet equipment
- Copper-to-fiber media conversion
- Intra-system fiber optic links
- ◆ Video surveillance systems

| Typical Coupled Power<br>$I_f = 100\text{mA}, 25^\circ\text{C}$ |              |      |         |
|---|--------------|------|---------|
| Fiber Size  | Type         | N.A. | OPF370A |
| 50/125 µm   | Graded Index | 0.20 | 29µW    |
| 62.5/125 µm   | Graded Index | 0.28 | 89µW    |
| 100/140 µm  | Graded Index | 0.29 | 200µW   |
| 200/300 µm  | Step Index   | 0.41 | 750µW   |



RoHS

## General Note

TT Electronics reserves the right to make changes in product specification without notice or liability. All information is subject to TT Electronics' own data and is considered accurate at time of going to print.

TT Electronics | OPTEK Technology  
2900 E. Plano Pkwy, Plano, TX 75074 | Ph: +1 972 323 2200  
www.ttelectronics.com | sensors@ttelectronics.com

### Mechanical Data

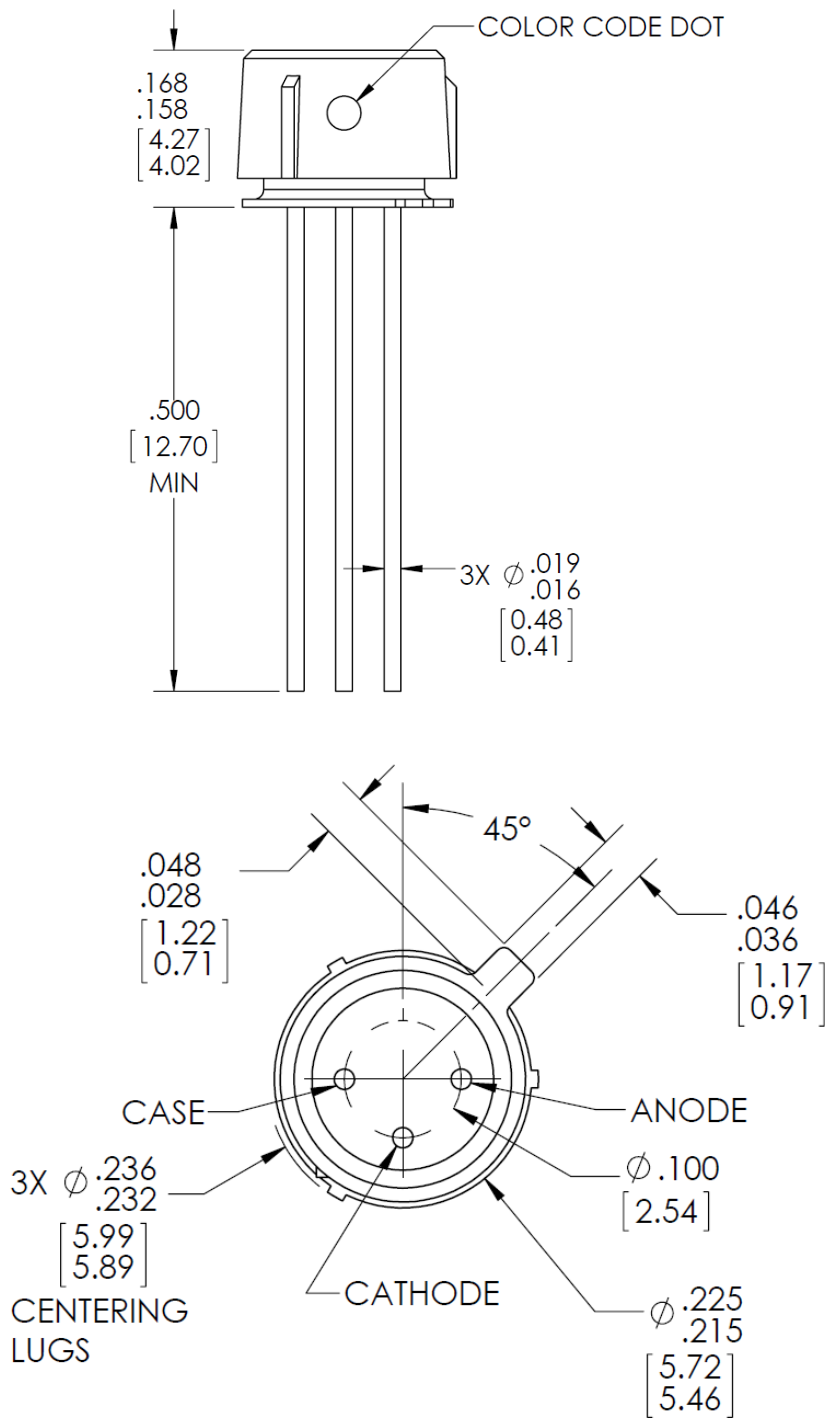

DIMENSIONS ARE IN INCHES (MILLIMETERS)

**General Note**

TT Electronics reserves the right to make changes in product specification without notice or liability. All information is subject to TT Electronics' own data and is considered accurate at time of going to print.

TT Electronics | OPTEK Technology  
 2900 E. Plano Pkwy, Plano, TX 75074 | Ph: +1 972 323 2200  
[www.ttelectronics.com](http://www.ttelectronics.com) | [sensors@ttelectronics.com](mailto:sensors@ttelectronics.com)

### Electrical Specifications

#### Absolute Maximum Ratings ( $T_A = 25^\circ\text{C}$ unless otherwise noted)

|   |                   |
|---|-------------------|
| Storage Temperature Range                 | -55° C to +115° C |
| Operating Temperature Range               | -40° C to +100° C |
| Lead Soldering Temperature <sup>(1)</sup> | 260° C            |
| Continuous Forward Current <sup>(2)</sup> | 100 mA            |
| Maximum Reverse Voltage                   | 1.0 V             |

#### Electrical Characteristics ( $T_A = 25^\circ\text{C}$ unless otherwise noted)

| SYMBOL          | PARAMETER           |         | MIN  | TYP  | MAX  | UNITS         | TEST CONDITIONS                                    |
|-----------------|---------------------|---------|------|------|------|---------------|--|
| $P_{T50}^{(3)}$ | Total Coupled Power | OPF370A | 25.0 | 29.0 |      | $\mu\text{W}$ | $I_F = 100\text{ mA}$                              |
| $V_F$           | Forward Voltage     |         |      | 1.8  | 2.2  | V             | $I_F = 100\text{ mA}$                              |
| $V_R$           | Reverse Voltage     |         | 1.8  |      |      | V             | $I_R = 100\ \mu\text{A}$                           |
| $\lambda$       | Wavelength          |         | 830  | 850  | 870  | nm            | $I_F = 50\text{ mA}$                               |
| $D\lambda$      | Optical Bandwidth   |         |      | 50   | 60   | nm            | $I_F = 50\text{ mA}$                               |
| $t_r, t_f$      | Rise and Fall Time  |         |      | 6.0  | 10.0 | ns            | $I_F = 100\text{ mA}; 10\% \text{ to } 90\%^{(4)}$ |

#### Notes:

- Maximum of 5 seconds with soldering iron. Duration can be extended to 10 seconds when flow soldering. RMA flux is recommended.
- De-rate linearly at 1.0mA /°C above 25°C .
- The component must be actively aligned into the mating fiber cable assembly to achieve optimal performance.
- No Pre-bias.
- All Optek fiber optic LED products are subjected to 100% burn-in as part of its quality control process. The burn-in conditions are 96 hours at 100mA drive current and 25°C ambient temperature.

#### General Note

TT Electronics reserves the right to make changes in product specification without notice or liability. All information is subject to TT Electronics' own data and is considered accurate at time of going to print.

### Performance

#### Relative Coupled Power vs. Forward Current

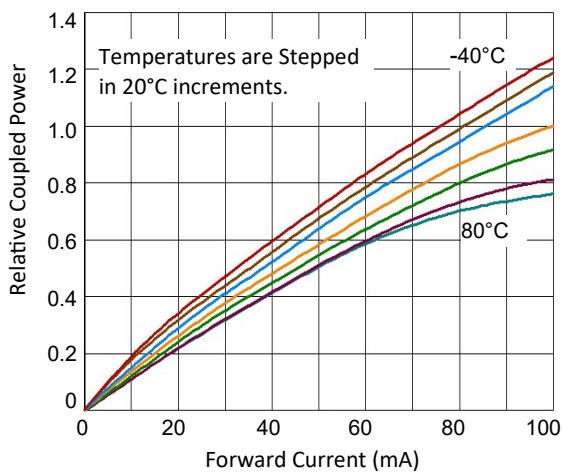

#### Typical Forward Voltage vs. Forward Current

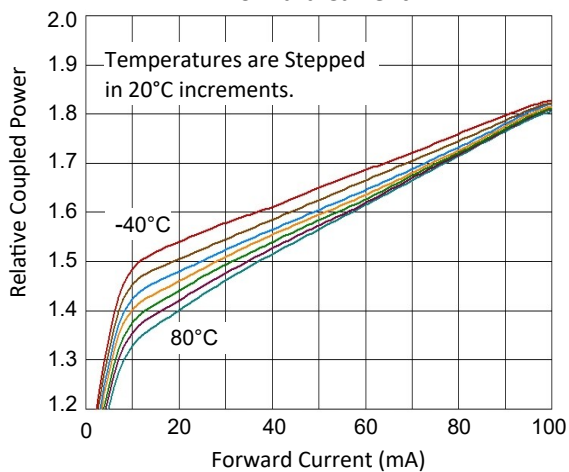

#### General Note

TT Electronics reserves the right to make changes in product specification without notice or liability. All information is subject to TT Electronics' own data and is considered accurate at time of going to print.

# Mouser Electronics

Authorized Distributor

Click to View Pricing, Inventory, Delivery & Lifecycle Information:

[TT Electronics:](#)

[OPF370A](#)