



CMD270P3

4-8 GHz Low Noise Amplifier

Features

- ▶ Ultra low noise figure
- ▶ High gain broadband performance
- ▶ Single supply voltage: +4.0 V @ 60 mA
- ▶ Pb-free RoHs compliant 3x3 QFN package

Description

The CMD270P3 is a broadband MMIC low noise amplifier housed in a leadless 3x3 mm plastic surface mount package. The CMD270P3 is ideally suited for EW and communications systems where small size and low power consumption are needed. The broadband device delivers greater than 16 dB of gain with a corresponding output 1 dB compression point of +18 dBm and a noise figure of 1.7 dB. The CMD270P3 is a 50 ohm matched design eliminating the need for external DC blocks and RF port matching.

Functional Block Diagram

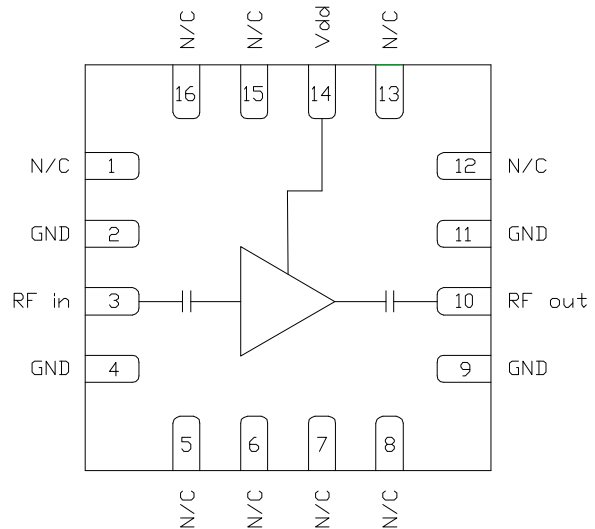

Electrical Performance - $V_{dd} = 4.0\text{ V}$, $T_A = 25\text{ }^\circ\text{C}$, $F = 6\text{ GHz}$

Parameter	Min	Typ	Max	Units
Frequency Range	4 - 8			GHz
Gain		16		dB
Noise Figure		1.7		dB
Input Return Loss		15		dB
Output Return Loss		11		dB
Output P1dB		18		dBm
Supply Current		60		mA

ver 1.0 0718



CMD270P3

4-8 GHz Low Noise Amplifier

Specifications

Absolute Maximum Ratings

Parameter	Rating
Drain Voltage, V _{dd}	5 V
RF Input Power	+20 dBm
Channel Temperature, T _{ch}	150 °C
Power Dissipation, P _{diss}	523 mW
Thermal Resistance Θ_{JC}	124.3 °C/W
Operating Temperature	-40 to 85 °C
Storage Temperature	-55 to 150 °C

Exceeding any one or combination of the maximum ratings may cause permanent damage to the device.

Recommended Operating Conditions

Parameter	Min	Typ	Max	Units
V _{dd}	2.0	4.0	5.0	V
I _{dd}		60		mA

Electrical performance is measured at specific test conditions. Electrical specifications are not guaranteed over all recommended operating conditions.

Electrical Specifications - V_{dd} = 4.0 V, T_A = 25 °C

Parameter	Min	Typ	Max	Min	Typ	Max	Units
Frequency Range	4 - 6			6 - 8			GHz
Gain	13.5	17.5	20	11	15.5	19	dB
Noise Figure		1.8	2.6		1.8	2.4	dB
Input Return Loss		11			12		dB
Output Return Loss		15			15		dB
Output P _{1dB}		18			19		dBm
Output IP ₃		28			31		dBm
Supply Current	40	60	80	40	60	80	mA
Gain Temperature Coefficient		0.008			0.008		dB/°C
Noise Figure Temperature Coefficient		0.008			0.008		dB/°C

ver 1.0 0718

Typical Performance

Broadband Performance, $V_{dd} = 4.0$ V, $I_{dd} = 60$ mA, $T_A = 25$ °C

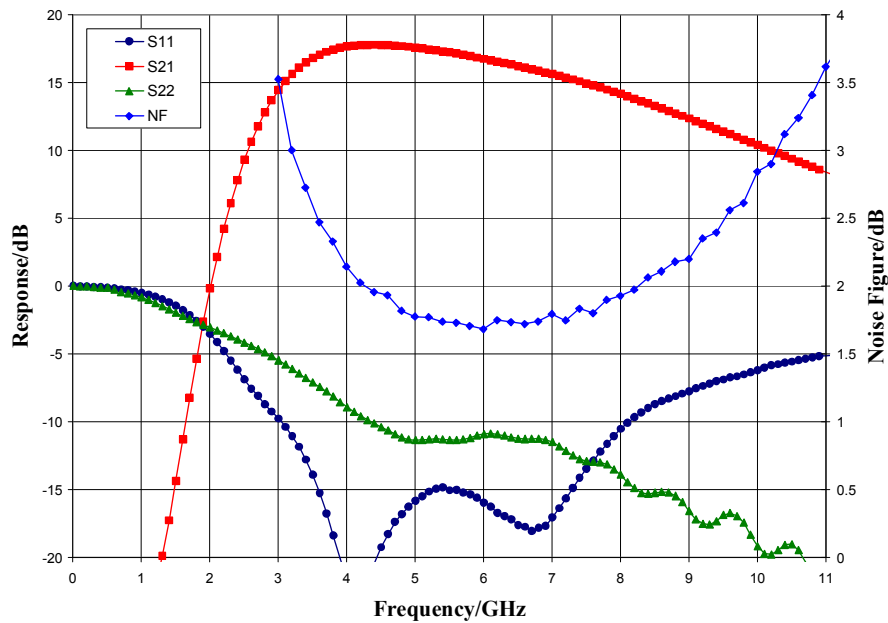

Narrow-band Performance, $V_{dd} = 4.0$ V, $I_{dd} = 60$ mA, $T_A = 25$ °C

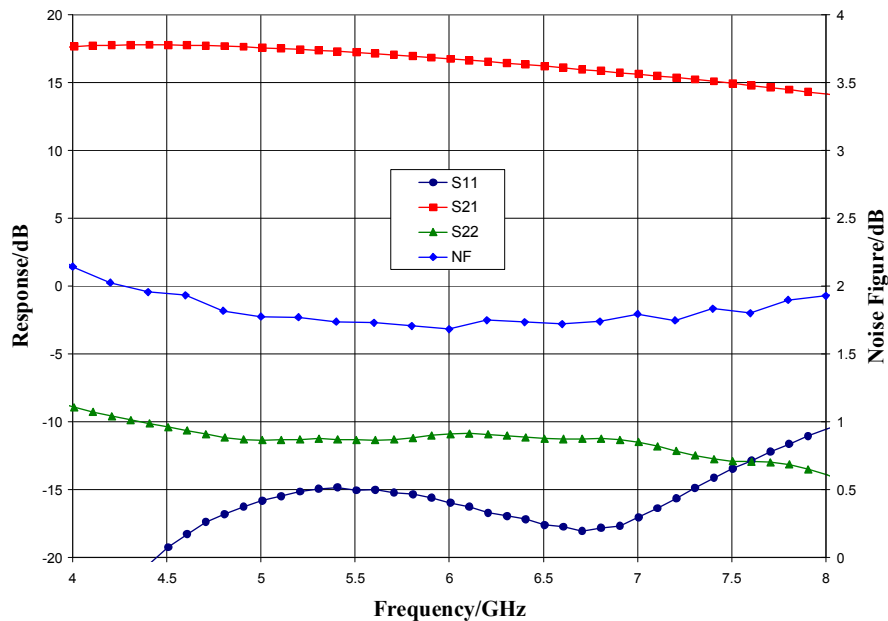

ver 1.0 0718

Typical Performance

Gain vs. Temperature, $V_{dd} = 4.0\text{ V}$

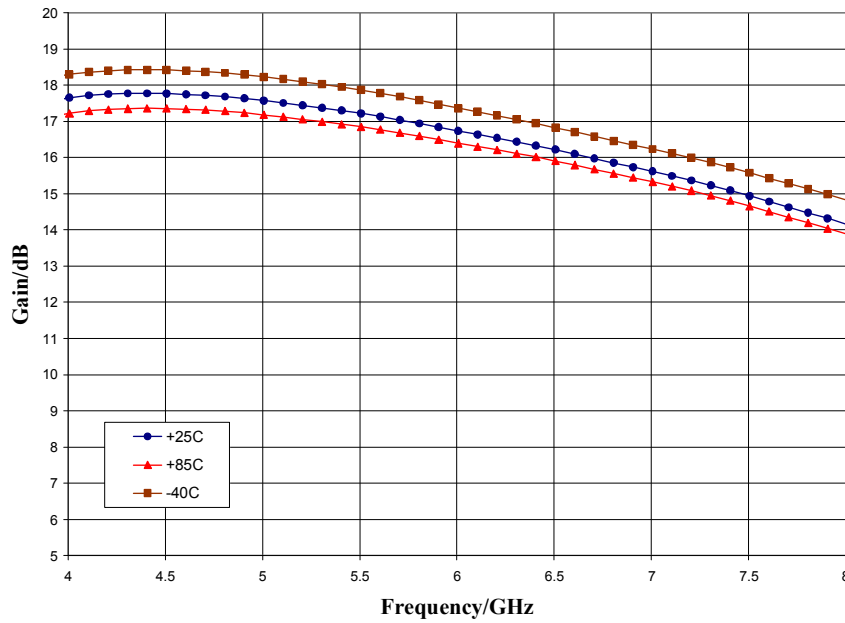

Noise Figure vs. Temperature, $V_{dd} = 4.0\text{ V}$

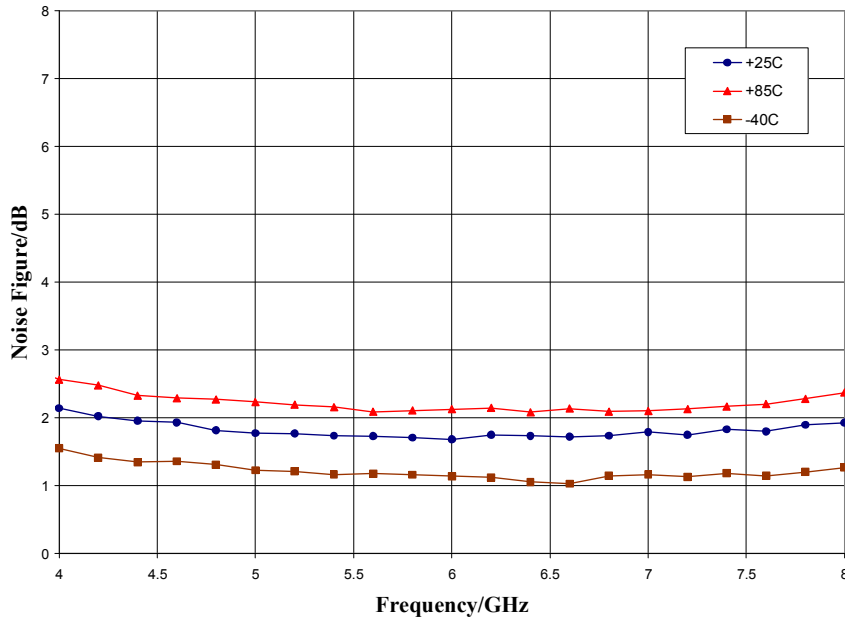

ver 1.0 0718

Typical Performance

P1dB vs. Temperature, $V_{dd} = 4.0\text{ V}$

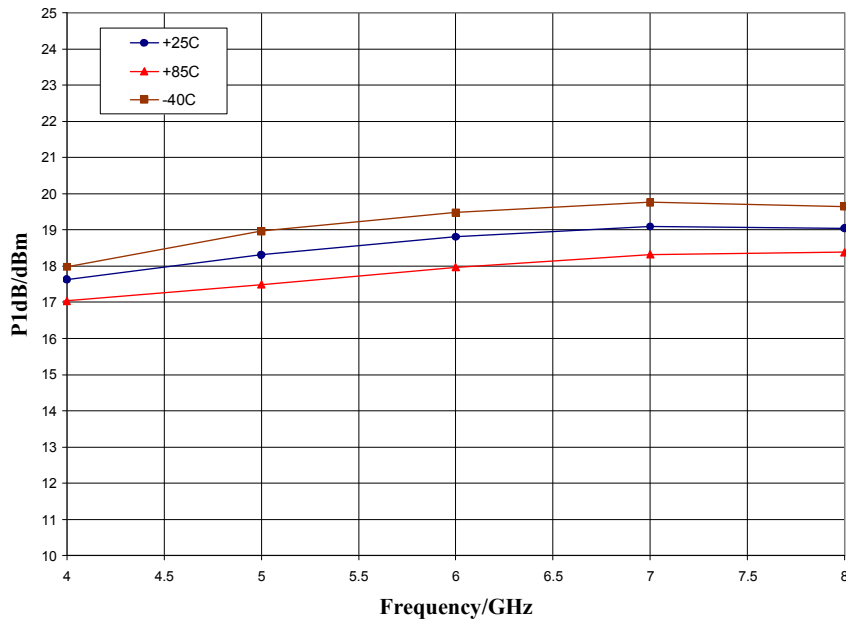

Output IP3 vs. Temperature, $V_{dd} = 4.0\text{ V}$

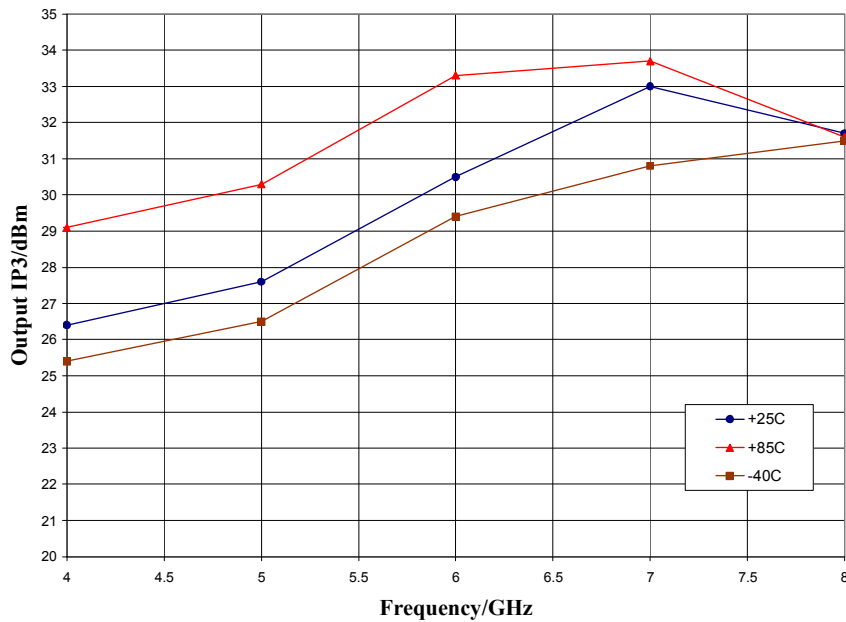

ver 1.0 0718

Mechanical Information

Package Information and Dimensions

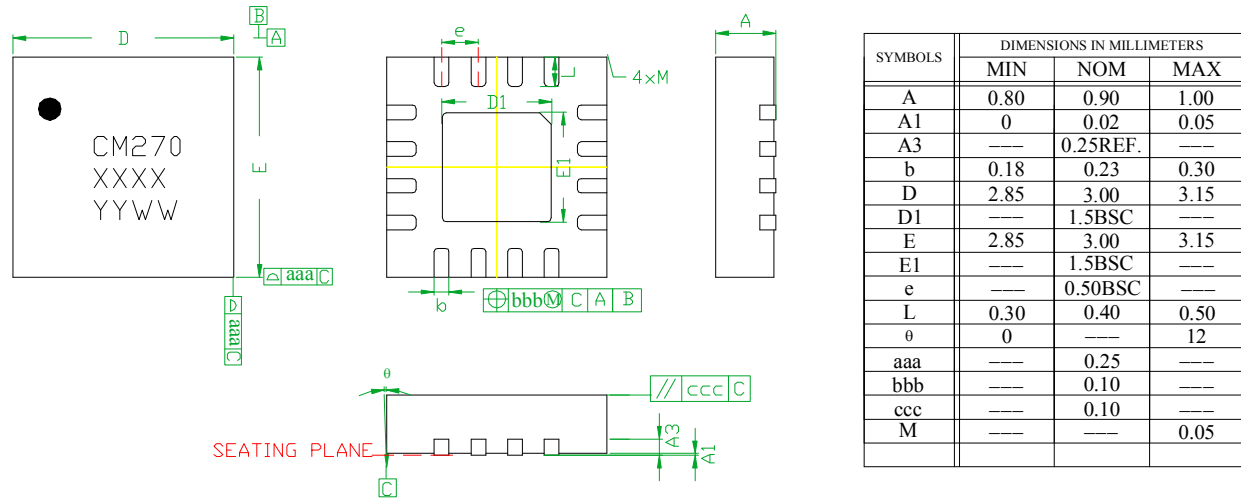

NOTES:

1. DIMENSIONS ARE IN MILLIMETERS
2. RoHS COMPLIANT MOLD COMPOUND
3. LEADFRAME MATERIAL: COPPER ALLOY
4. LEAD FINISH: 100% MATTE Sn
5. INDICATED DIMENSION/TOLERANCE APPLIES TO LEADS AND EXPOSED PAD

Recommended PCB Land Pattern

Custom MMIC recommends that the user develop the land pattern that will provide the best design for proper solder reflow and device attach for their specific application. Please review Custom MMIC Application Note AN 105 for a recommended land pattern approach.

Recommended Solder Reflow Profile



Custom MMIC recommends screen printing with belt furnace reflow to ensure proper solder reflow and device attach. Please review Custom MMIC Application Note AN 102 for a recommended solder reflow profile.

Pin Description

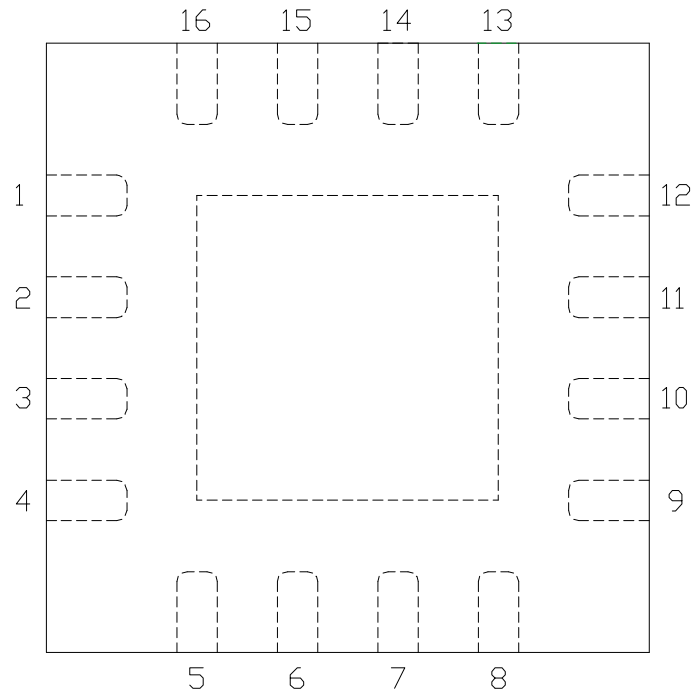
Pin Diagram

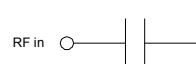

Functional Description

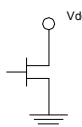
Pin	Function	Description	Schematic
1, 5-8, 12, 13, 15, 16	N/C	No connection required. These pins may be connected to RF/DC ground.	
2, 4, 9, 11 and die paddle	Ground	Connect to RF / DC ground	
3	RF in	DC blocked and 50 ohm matched	
10	RF out	DC blocked and 50 ohm matched	
14	Vdd	Power supply voltage Decoupling and bypass caps required	

ver 1.0 0718

Applications Information

Application Circuit

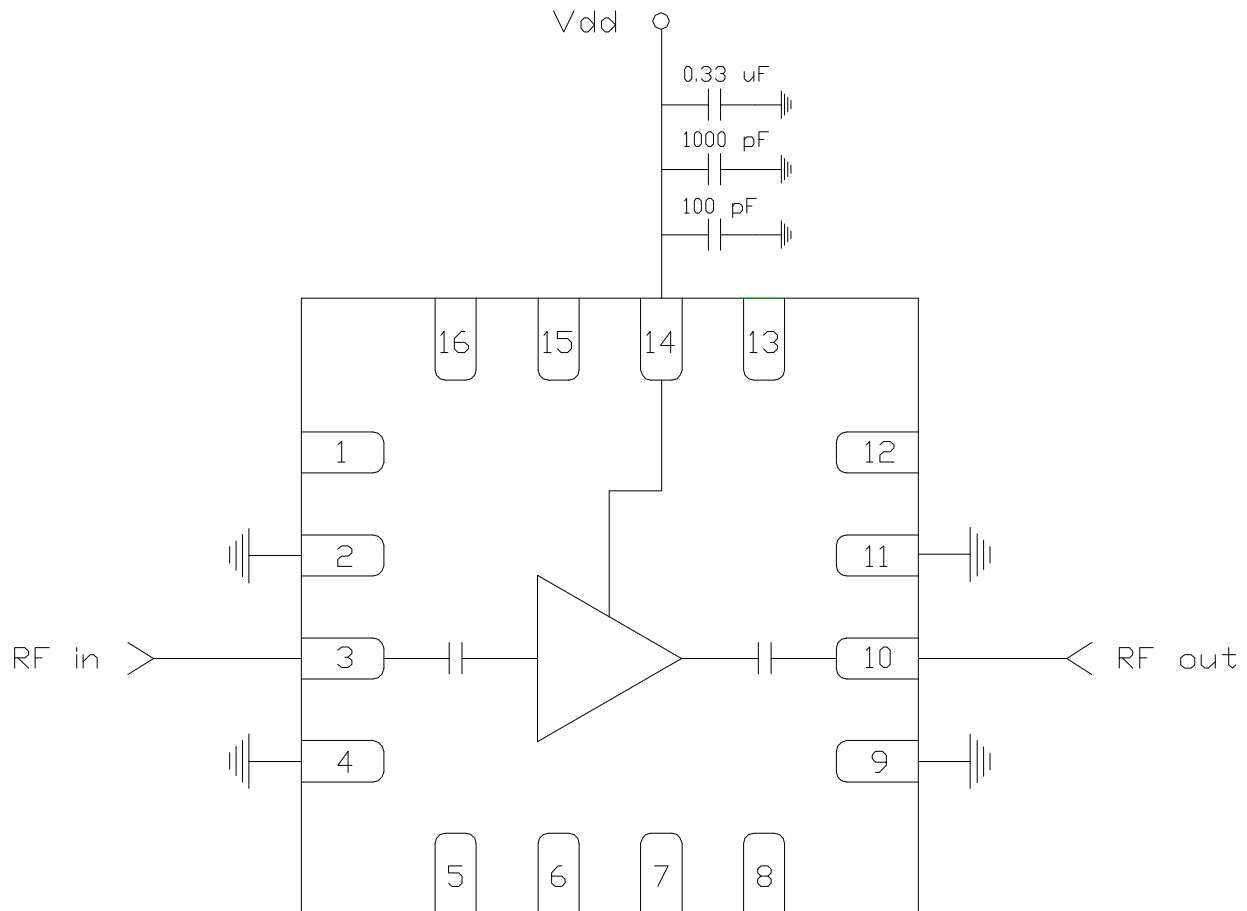

Biasing and Operation

The CMD270P3 is biased with a single 4.0 V positive drain supply.

RF power can be applied at any time.

GaAs MMIC devices are susceptible to damage from Electrostatic Discharge. Proper precautions should be observed during handling, assembly and test.

ver 1.0 0718

Applications Information

Evaluation Board

The circuit board shown has been developed for optimized assembly at Custom MMIC. A sufficient number of via holes should be used to connect the top and bottom ground planes. As surface mount processes vary, careful process development is recommended.

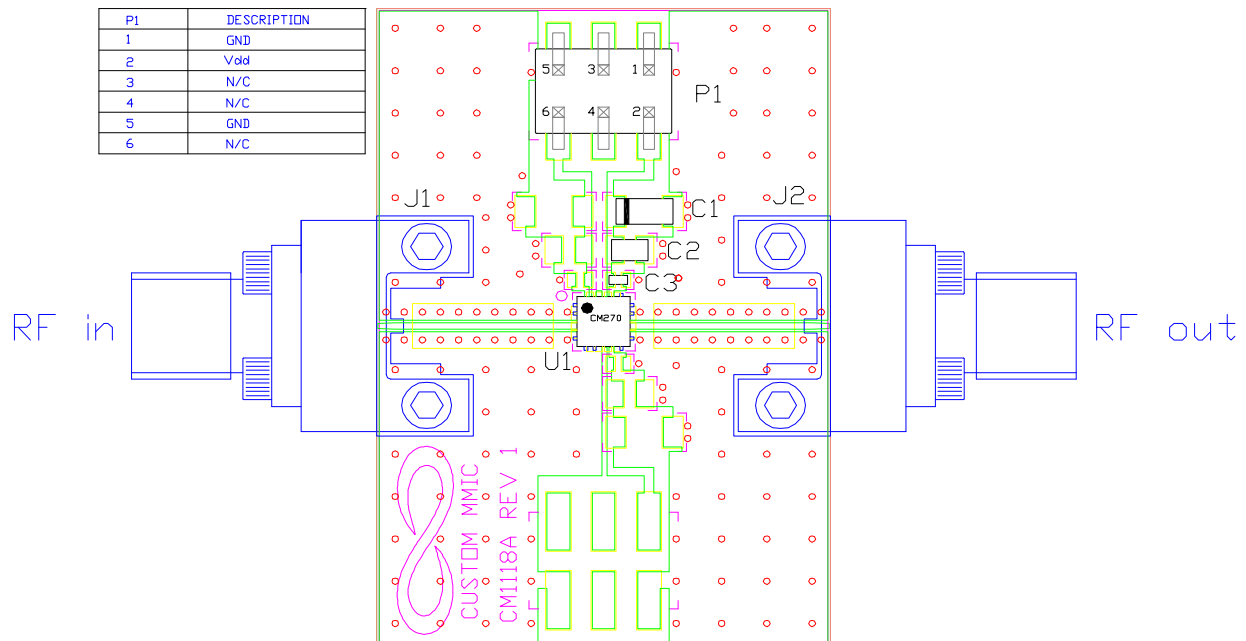

Bill of Material

Designator	Value	Description
J1, J2		SMA End Launch Connector
P1		10 Pin Header
C1	0.33 µF	Capacitor, Tantalum
C2	1000 pF	Capacitor, 0603
C3	100 pF	Capacitor, 0402
U1		CMD270P3 Low Noise Amplifier
PCB		CM1118A Evaluation PCB

Mouser Electronics

Authorized Distributor

Click to View Pricing, Inventory, Delivery & Lifecycle Information:

Qorvo:

[CMD270P3](#) [CMD270P3-EVB](#)