

Product Description

The QPB4221 is a complete integrated bias card assembly to be used with a variety of millimeter-wave Spatium solid state power amplifiers. It is specifically designed to be integrated onto the SSPA, allowing for reduced size and weight, while also reducing electrical losses in the bias networks. It provides for individualized bias settings for each amplifier blade in the SSPA. It is compatible with drain enable millimeter-wave Spatium products and can support additional drain supply capacitor banks.

All QPB4221s are pre-programmed for standard operating conditions when paired with a Spatium product. Any change of bias from this condition needs to be evaluated from both an electrical and thermal perspective. Qorvo strongly recommends working with our applications and engineering teams for proper programming of devices should system needs require.

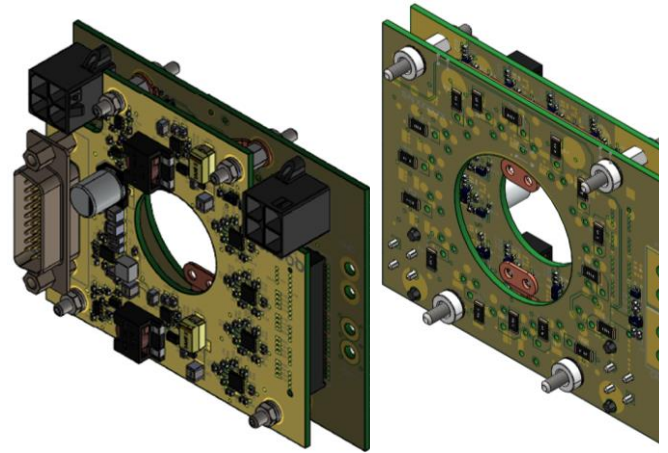

Functional Block Diagram

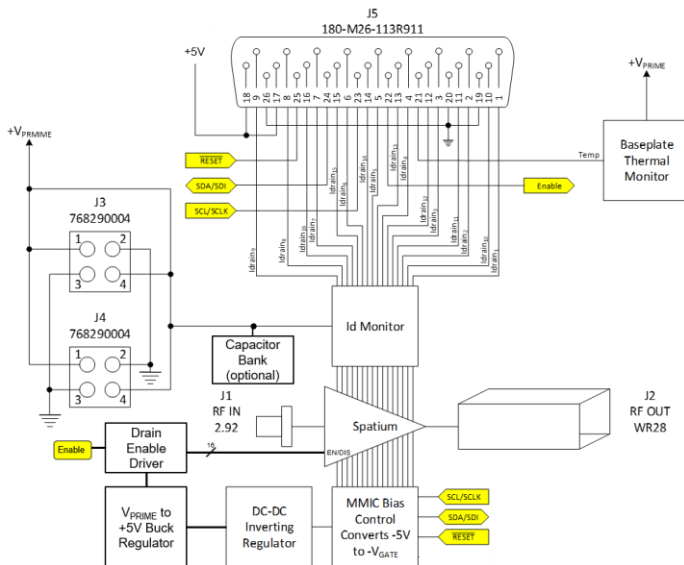

Product Features

- Complete 16-Ch bias controller For Spatium amplifiers
- 3.6" x 3" PCB form factor
- High DC current capability
- Low power dissipation
- Keyed and shrouded connectors
- Temperature compensation available
- I2C Communications
- Scaled bias point voltage
- Compatible with blade protection electronics
- Compatible with additional capacitor bank
- Fast Drain Enable switching delay

Applications

- Integrated controller for millimeter wave Spatium SSPA

Ordering Information

Part No.	Description
QPB4221	Integrated Bias Controller Card

Absolute Maximum Ratings

Parameter	Value / Range
Supply Voltage (+VD)	+30 V
Max Drain Current Per Channel, All channels ON (ID_ch)	5 A
Max Operating Temp (TOP)	-40 to +85 °C
Storage Temp (TSTORE)	-40 to 125 °C
Enable Voltage (+VENABLE)	+6.5 V

Operation of this device outside the parameter ranges given above may cause permanent damage. These are stress ratings only, and functional operation of the device at these conditions is not implied.

Recommended Operating Conditions

Parameter	Value / Range
Drain Voltage (VD)	20 – 28 V
Quiescent Drain Current (IDQ)	4.5 – 5.0 A
Operating Drain Current (ID)	30 – 34 A
Operating Temperature	-40 to +50 °C

Electrical specifications are measured at specified test conditions. Specifications are not guaranteed over all recommended operating conditions.

Electrical Specifications

Parameter	Min	Typ	Max	Units
Gate Voltage Control Range	-3.6		-1.3	V
Gate Voltage Temperature Compensation	-10		10	mV/°C
Gate Voltage Step Size		10		mV
Gate Current (per channel, continuous)	-75		100	mA
Average Drain Current (per channel)			4	A
Temperature Monitor Response	-14		-13	mV/°C
Temperature Monitor Accuracy	-5		5	%
Drain Current Monitor Response		0.5		V/A
Drain Current Monitor Accuracy	-10		10	%
Transmit Ready Time			7	ms
Drain Enable Switching Delay		65		ns
Dimensions – Amplifier Unit (L) x (W) x (H) (including connector lengths)		3.60 x 2.79 x 1.02		inches
		91.4 x 70.9 x 25.9		millimeters
Weight		0.5 / 0.227		pound / kg

Functional Block Diagram

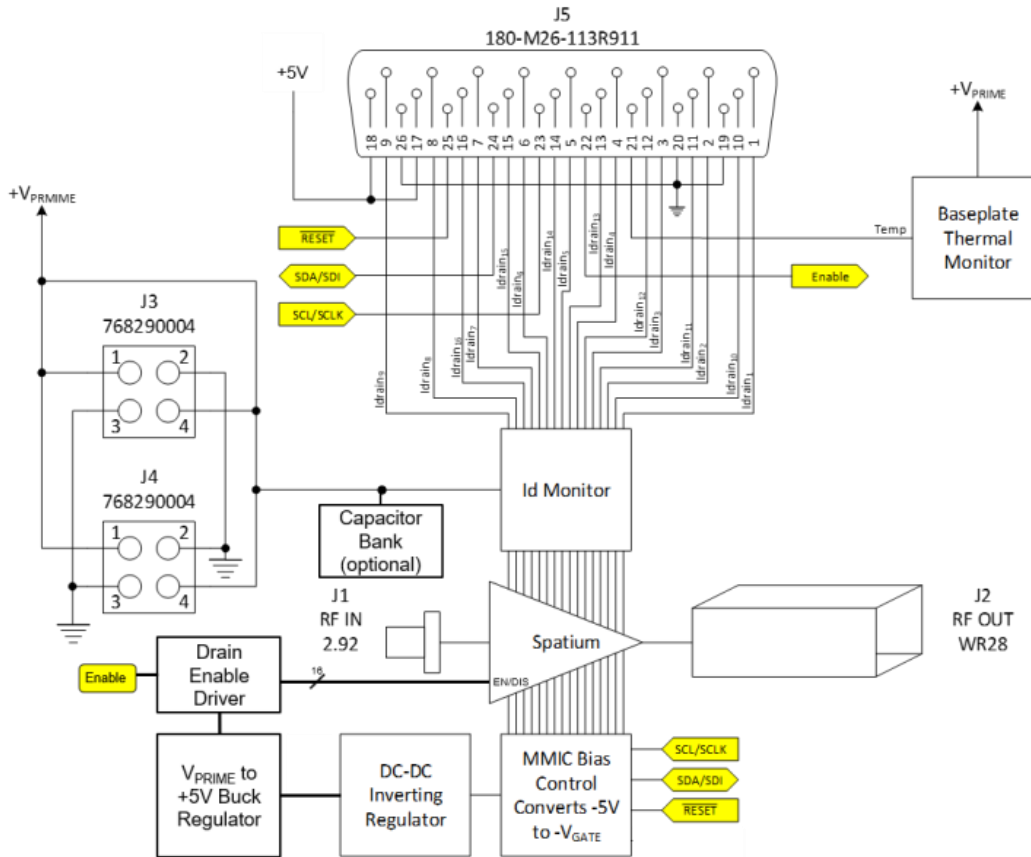

Electrical Connectors

Label	Part Number	Function
J1	180-M26-113R911	Mating bias connector to Spatium
J3	768290004	V _{PRIME} input power connector
J4	768290004	V _{PRIME} input power connector

Operational Description

The QPB4221 bias card allows the user to control the Spatium blade circuits by independently adjusting the gate voltage setpoint for each channel in the system. Communications for programming are handled through an I²C bus accessed through the DSUB26 (J1) connector interface. Channels are organized into groups of 4 by use of both a device and RDAC address. Blades 1-4 are on device address 0101111 with RDAC address 00 for channel 1, 01 for channel 2, etc. Blades 5-8 are on device address 0100011, blades 9-12 are on device address 0100000, and blades 13-16 are on device address 0101100 with channel number and RDAC both increasing similarly. Control voltages are established through a RDAC value between 0x00 to 0xFF (decimal 0 to 255) with 0xFF being equivalent to a gate voltage of -3.3 V and 0x00 being equivalent to -1.2 V, allowing coverage for a range of GaN devices.

All QPB4221s are pre-programmed for standard operating conditions when paired with a Spatium product. Any change of bias from this condition needs to be evaluated from both an electrical and thermal perspective. Qorvo strongly recommends working with our applications and engineering teams for proper programming of devices should system needs require.

Mechanical Information – Outline Drawing and Connector Assignments

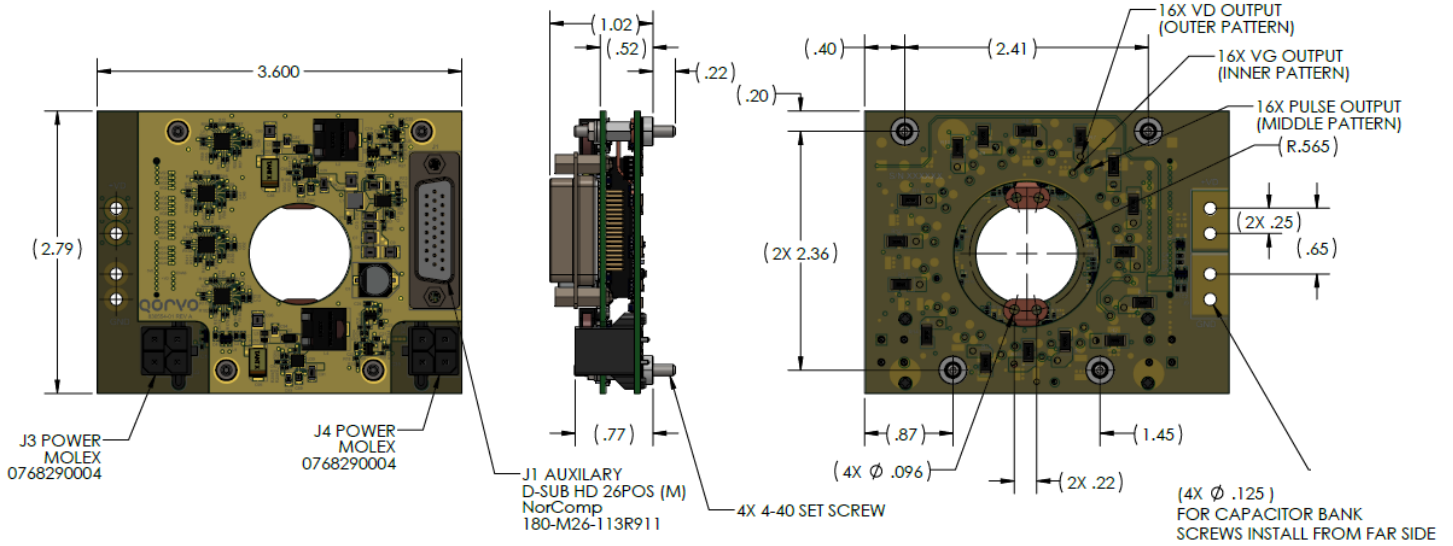

Dimensions are in INCHES

J1 AUXILIARY	
PIN	SIGNAL
1	IDRAIN1
2	IDRAIN2
3	IDRAIN3
4	IDRAIN4
5	IDRAIN5
6	IDRAIN6
7	IDRAIN7
8	IDRAIN8
9	IDRAIN9
10	IDRAIN10
11	IDRAIN11
12	IDRAIN12
13	IDRAIN13
14	IDRAIN14
15	IDRAIN15
16	IDRAIN16
17	+5 V (1)
18	+5 V (1)
19	GND
20	GND
21	VTEMP
22	ENABLE
23	SLC
24	SDA
25	RESET
26	GND

J3 AND J4 POWER	
PIN	SIGNAL
1	+VD
2	GND
3	GND
4	+VD

(1) + 5 V is present on pins 17 and 18.
Do not connect a voltage to these pins

Mechanical Information – 3D View (to Spatium)

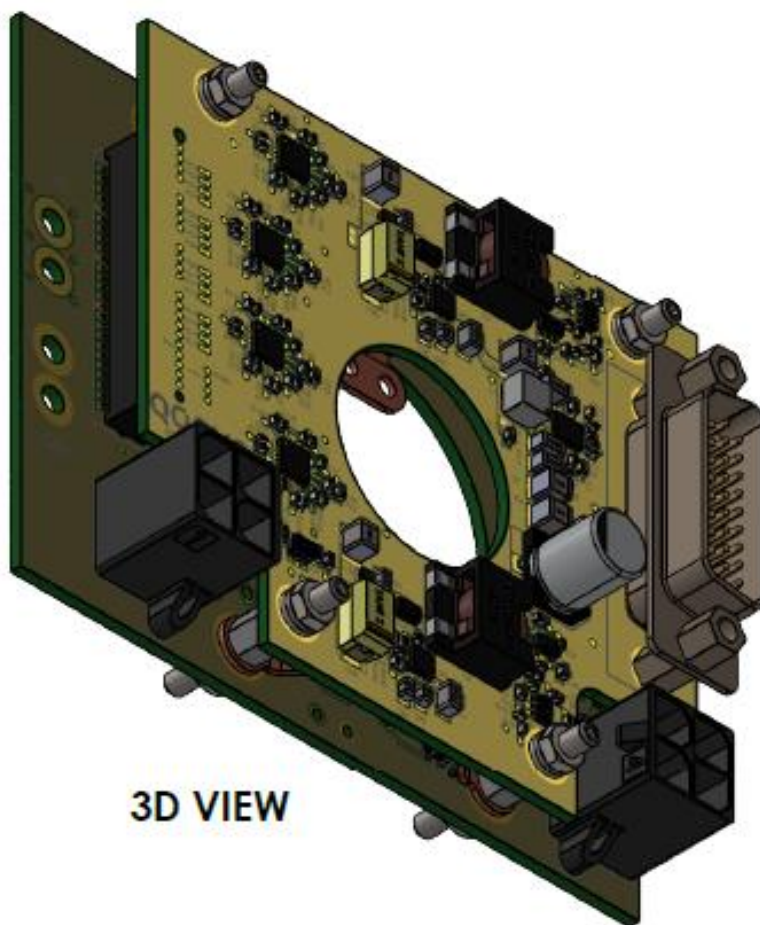

Handling Precautions



Caution!
ESD-Sensitive Device

HIGH DC CURRENT HAZARD: High levels of DC current are present when the unit is operating.

Contact Information

For the latest specifications, additional product information, worldwide sales and distribution locations:

Web: www.qorvo.com

Tel: 1-844-890-8163

Email: customer.support@qorvo.com

Important Notice

The information contained herein is believed to be reliable; however, Qorvo makes no warranties regarding the information contained herein and assumes no responsibility or liability whatsoever for the use of the information contained herein. All information contained herein is subject to change without notice. Customers should obtain and verify the latest relevant information before placing orders for Qorvo products. The information contained herein or any use of such information does not grant, explicitly or implicitly, to any party any patent rights, licenses, or any other intellectual property rights, whether with regard to such information itself or anything described by such information. **THIS INFORMATION DOES NOT CONSTITUTE A WARRANTY WITH RESPECT TO THE PRODUCTS DESCRIBED HEREIN, AND QORVO HEREBY DISCLAIMS ANY AND ALL WARRANTIES WITH RESPECT TO SUCH PRODUCTS WHETHER EXPRESS OR IMPLIED BY LAW, COURSE OF DEALING, COURSE OF PERFORMANCE, USAGE OF TRADE OR OTHERWISE, INCLUDING THE IMPLIED WARRANTIES OF MERCHANTABILITY AND FITNESS FOR A PARTICULAR PURPOSE.**

Without limiting the generality of the foregoing, Qorvo products are not warranted or authorized for use as critical components in medical, life-saving, or life-sustaining applications, or other applications where a failure would reasonably be expected to cause severe personal injury or death.

© 2020 Qorvo US, Inc. All rights reserved. This document is subject to copyright laws in various jurisdictions worldwide and may not be reproduced or distributed, in whole or in part, without the express written consent of Qorvo US, Inc.

Mouser Electronics

Authorized Distributor

Click to View Pricing, Inventory, Delivery & Lifecycle Information:

[Qorvo:](#)

[QPB4221](#)