

LFx5x JFET Input Operational Amplifiers

1 Features

- Advantages
 - Replace Expensive Hybrid and Module FET Op Amps
 - Rugged JFETs Allow Blow-Out Free Handling Compared With MOSFET Input Devices
 - Excellent for Low Noise Applications Using Either High or Low Source Impedance—Very Low 1/f Corner
 - Offset Adjust Does Not Degrade Drift or Common-Mode Rejection as in Most Monolithic Amplifiers
 - New Output Stage Allows Use of Large Capacitive Loads (5,000 pF) Without Stability Problems
 - Internal Compensation and Large Differential Input Voltage Capability
- Common Features
 - Low Input Bias Current: 30 pA
 - Low Input Offset Current: 3 pA
 - High Input Impedance: $10^{12} \Omega$
 - Low Input Noise Current: $0.01 \text{ pA}/\sqrt{\text{Hz}}$
 - High Common-Mode Rejection Ratio: 100 dB
 - Large DC Voltage Gain: 106 dB
- Uncommon Features
 - Extremely Fast Settling Time to 0.01%:
 - 4 μs for the LFx55 devices
 - 1.5 μs for the LFx56
 - 1.5 μs for the LFx57 ($A_V = 5$)
 - Fast Slew Rate:
 - 5 $\text{V}/\mu\text{s}$ for the LFx55
 - 12 $\text{V}/\mu\text{s}$ for the LFx56
 - 50 $\text{V}/\mu\text{s}$ for the LFx57 ($A_V = 5$)
 - Wide Gain Bandwidth:
 - 2.5 MHz for the LFx55 devices
 - 5 MHz for the LFx56
 - 20 MHz for the LFx57 ($A_V = 5$)
 - Low Input Noise Voltage:
 - 20 $\text{nV}/\sqrt{\text{Hz}}$ for the LFx55
 - 12 $\text{nV}/\sqrt{\text{Hz}}$ for the LFx56
 - 12 $\text{nV}/\sqrt{\text{Hz}}$ for the LFx57 ($A_V = 5$)

2 Applications

- Precision High-Speed Integrators
- Fast D/A and A/D Converters
- High Impedance Buffers
- Wideband, Low Noise, Low Drift Amplifiers
- Logarithmic Amplifiers
- Photocell Amplifiers
- Sample and Hold Circuits

3 Description

The LFx5x devices are the first monolithic JFET input operational amplifiers to incorporate well-matched, high-voltage JFETs on the same chip with standard bipolar transistors (BI-FET™ Technology). These amplifiers feature low input bias and offset currents/low offset voltage and offset voltage drift, coupled with offset adjust, which does not degrade drift or common-mode rejection. The devices are also designed for high slew rate, wide bandwidth, extremely fast settling time, low voltage and current noise and a low 1/f noise corner.

Device Information⁽¹⁾

PART NUMBER	PACKAGE	BODY SIZE (NOM)
LFx5x	SOIC (8)	4.90 mm × 3.91 mm
	TO-CAN (8)	9.08 mm × 9.08 mm
	PDIP (8)	9.81 mm × 6.35 mm

(1) For all available packages, see the orderable addendum at the end of the data sheet.

Simplified Schematic

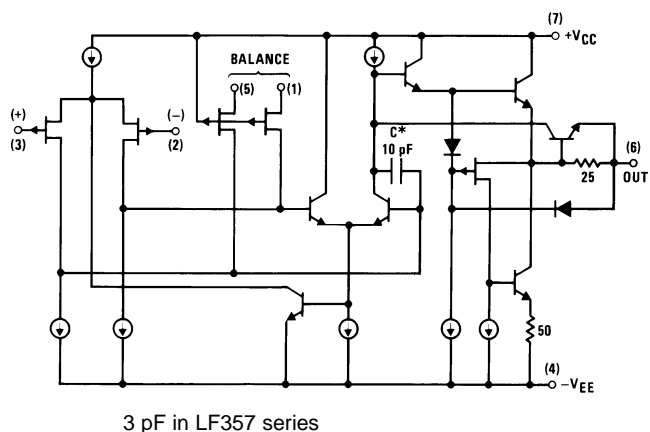

Table of Contents

1 Features	1	7.2 Functional Block Diagram	15
2 Applications	1	7.3 Feature Description	16
3 Description	1	7.4 Device Functional Modes	16
4 Revision History	2	8 Application and Implementation	17
5 Pin Configuration and Functions	3	8.1 Application Information	17
6 Specifications	4	8.2 Typical Application	18
6.1 Absolute Maximum Ratings	4	8.3 System Examples	20
6.2 ESD Ratings	4	9 Power Supply Recommendations	33
6.3 Recommended Operating Conditions	4	10 Layout	33
6.4 Thermal Information	5	10.1 Layout Guidelines	33
6.5 AC Electrical Characteristics, $T_A = T_J = 25^\circ\text{C}$, $V_S = \pm 15\text{ V}$	5	10.2 Layout Example	34
6.6 DC Electrical Characteristics, $T_A = T_J = 25^\circ\text{C}$, $V_S = \pm 15\text{ V}$	6	11 Device and Documentation Support	35
6.7 DC Electrical Characteristics	6	11.1 Related Links	35
6.8 Power Dissipation Ratings	7	11.2 Community Resources	35
6.9 Typical Characteristics	8	11.3 Trademarks	35
7 Detailed Description	14	11.4 Electrostatic Discharge Caution	35
7.1 Overview	14	11.5 Glossary	35
		12 Mechanical, Packaging, and Orderable Information	35

4 Revision History

NOTE: Page numbers for previous revisions may differ from page numbers in the current version.

Changes from Revision C (March 2013) to Revision D	Page
<ul style="list-style-type: none"> Added <i>Pin Configuration and Functions</i> section, <i>ESD Ratings</i> table, <i>Thermal Information</i> table, <i>Feature Description</i> section, <i>Device Functional Modes</i>, <i>Application and Implementation</i> section, <i>Power Supply Recommendations</i> section, <i>Layout</i> section, <i>Device and Documentation Support</i> section, and <i>Mechanical, Packaging, and Orderable Information</i> section 	1
<ul style="list-style-type: none"> Removed T_{HIGH} parameter as it is redundant to T_A maximum 	4

Changes from Revision B (March 2013) to Revision C	Page
<ul style="list-style-type: none"> Changed layout of National Data Sheet to TI format 	31

5 Pin Configuration and Functions

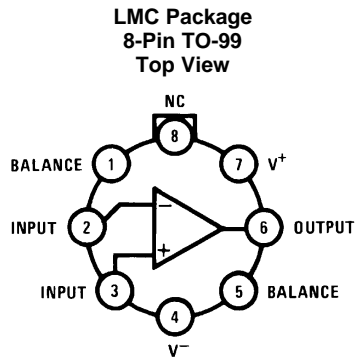

Available per JM38510/11401 or
JM38510/11402

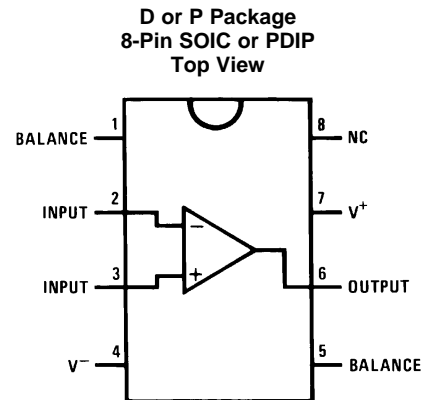

Pin Functions

PIN		I/O	DESCRIPTION
NAME	NO.		
BALANCE	1, 5	I	Balance for input offset voltage
+INPUT	3	I	Noninverting input
-INPUT	2	I	Inverting input
NC	8	—	No connection
OUTPUT	6	O	Output
V+	7	—	Positive power supply
V-	4	—	Negative power supply

6 Specifications

6.1 Absolute Maximum Ratings

over operating free-air temperature range (unless otherwise noted) ⁽¹⁾⁽²⁾⁽³⁾

		MIN	MAX	UNIT	
Supply voltage	LF155x, LF256x, LF356B		±22	V	
	LF35x		±18		
Differential input voltage	LF15x, LF25x, LF356B		±40	V	
	LF35x		±30		
Input voltage ⁽⁴⁾	LF15x, LF25x, LF356B		±20	V	
	LF35x		±16		
Output short circuit duration			Continuous	—	
T _{JMAX}	LMC package	LF15x	150	°C	
		LF25x, LF356B, LF35x	115		
	P package	LF25x, LF356B, LF35x	100		
	D package	LF25x, LF356B, LF35x	100		
Soldering information (lead temp.)	TO-99 package	Soldering (10 sec.)		°C	
	PDIP package	Soldering (10 sec.)			
	SOIC package	Vapor phase (60 sec.)	LF25x, LF356B, LF35x		215
		Infrared (15 sec.)	LF25x, LF356B, LF35x		220
Storage temperature, T _{stg}		-65	150	°C	

- Stresses beyond those listed under *Absolute Maximum Ratings* may cause permanent damage to the device. These are stress ratings only, which do not imply functional operation of the device at these or any other conditions beyond those indicated under *Recommended Operating Conditions*. Exposure to absolute-maximum-rated conditions for extended periods may affect device reliability.
- The maximum power dissipation for these devices must be derated at elevated temperatures and is dictated by T_{JMAX}, θ_{JA}, and the ambient temperature, T_A. The maximum available power dissipation at any temperature is P_D = (T_{JMAX} - T_A) / θ_{JA} or the 25°C P_{dMAX}, whichever is less.
- If Military/Aerospace specified devices are required, contact the TI Sales Office/Distributors for availability and specifications.
- Unless otherwise specified the absolute maximum negative input voltage is equal to the negative power supply voltage.

6.2 ESD Ratings

		VALUE	UNIT
V _(ESD)	Electrostatic discharge	Human body model (HBM), per ANSI/ESDA/JEDEC JS-001 ⁽¹⁾⁽²⁾	±1000 V

- JEDEC document JEP155 states that 500-V HBM allows safe manufacturing with a standard ESD control process.
- 100 pF discharged through 1.5-kΩ resistor

6.3 Recommended Operating Conditions

over operating free-air temperature range (unless otherwise noted)

		MIN	NOM	MAX	UNIT
Supply voltage, V _S	LF15x	±15	V _S	±20	V
	LF25x	±15	V _S	±20	
	LF356B	±15	V _S	±20	
	LF35x			±15	
T _A	LF15x	-55	T _A	125	°C
	LF25x	-25	T _A	85	
	LF356B	0	T _A	70	
	LF35x	0	T _A	70	

6.4 Thermal Information

THERMAL METRIC ⁽¹⁾		LF155, LF156, LF355, LF357			LF356	UNIT
		P (PDIP)	D (SOIC)	LMC (TO-99)	P (PDIP)	
		8 PINS	8 PINS	8 PINS	8 PINS	
R _{θJA}	Junction-to-ambient thermal resistance	130	195	—	55.2	°C/W
	Still Air	—	—	160	—	
	400 LF/Min Air Flow	—	—	65	—	
R _{θJC(top)}	Junction-to-case (top) thermal resistance	—	—	23	44.5	°C/W
R _{θJB}	Junction-to-board thermal resistance	—	—	—	32.4	°C/W
ψ _{JT}	Junction-to-top characterization parameter	—	—	—	21.7	°C/W
ψ _{JB}	Junction-to-board characterization parameter	—	—	—	32.3	°C/W

(1) For more information about traditional and new thermal metrics, see the *Semiconductor and IC Package Thermal Metrics* application report, [SPRA953](#).

6.5 AC Electrical Characteristics, T_A = T_J = 25°C, V_S = ±15 V

PARAMETER		TEST CONDITIONS		MIN	TYP	MAX	UNIT
SR	Slew Rate	LF15x: A _V = 1	LFx55		5		V/μs
			LFx56, LF356B		7.5		
			LFx56, LF356B		12		
		LF357: A _V = 5	LFx57		50		
GBW	Gain Bandwidth Product	LFx55			2.5		MHz
		LFx56, LF356B			5		
		LFx57			20		
t _s	Settling Time to 0.01% ⁽¹⁾	LFx55			4		μs
		LFx56, LF356B			1.5		
		LFx57			1.5		
e _n	Equivalent Input Noise Voltage	R _S = 100 Ω	f = 100 Hz	LFx55		25	nV/√Hz
				LFx56, LF356B		15	
				LFx57		15	
			f = 1000 Hz	LFx55		20	nV/√Hz
				LFx56, LF356B		12	
				LFx57		12	
i _n	Equivalent Input Current Noise	f = 100 Hz	LFx55		0.01	pA/√Hz	
			LFx56, LF356B		0.01		
			LFx57		0.01		
		f = 1000 Hz	LFx55		0.01	pA/√Hz	
			LFx56, LF356B		0.01		
			LFx57		0.01		
C _{IN}	Input Capacitance	LFx55			3	pF	
		LFx56, LF356B			3		
		LFx57			3		

(1) Settling time is defined here, for a unity gain inverter connection using 2-kΩ resistors for the LF15x. It is the time required for the error voltage (the voltage at the inverting input pin on the amplifier) to settle to within 0.01% of its final value from the time a 10-V step input is applied to the inverter. For the LF357, A_V = -5, the feedback resistor from output to input is 2 kΩ and the output step is 10 V (See [Settling Time Test Circuit](#)).

6.6 DC Electrical Characteristics, $T_A = T_J = 25^\circ\text{C}$, $V_S = \pm 15\text{ V}$

PARAMETER	TEST CONDITIONS	MIN	TYP	MAX	UNIT
Supply current	LF155		2	4	mA
	LF355		2	4	
	LFx56, LF356B		5	7	
	LF356		5	10	
	LF357		5	10	

6.7 DC Electrical Characteristics

See ⁽¹⁾

PARAMETER	TEST CONDITIONS		MIN	TYP	MAX	UNIT
V_{OS} Input offset voltage	$R_S = 50\ \Omega$	$T_A = 25^\circ\text{C}$	LF15x, LF25x, LF356B	3	5	mV
			LF35x	3	10	
	Over temperature		LF15x		7	
			LF25x, LF356B		6.5	
			LF35x		13	
$\Delta V_{OS}/\Delta T$ Average TC of input offset voltage	$R_S = 50\ \Omega$		LF15x, LF25x, LF356B, LF35x	5		$\mu\text{V}/^\circ\text{C}$
$\Delta TC/\Delta V_{OS}$ Change in average TC with V_{OS} adjust	$R_S = 50\ \Omega^{(2)}$		LF15x, LF25x, LF356B, LF35x	0.5		$\mu\text{V}/^\circ\text{C}$ per mV
I_{OS} Input offset current	$T_J = 25^\circ\text{C}^{(1) (3)}$		LF15x, LF25x, LF356B	3	20	pA
			LF35x	3	50	
	$T_J \leq T_{HIGH}$		LF15x		20	nA
			LF25x, LF356B		1	
			LF35x		2	
I_B Input bias current	$T_J = 25^\circ\text{C}^{(1) (3)}$		LF15x, LF25x, LF356B	30	100	pA
			LF35x	30	200	
	$T_J \leq T_{HIGH}$		LF15x		50	nA
			LF25x, LF356B		5	
			LF35x		8	
R_{IN} Input resistance	$T_J = 25^\circ\text{C}$		LF15x, LF25x, LF356B, LF35x	10^{12}		Ω
A_{VOL} Large signal voltage gain	$V_S = \pm 15\text{ V}$, $V_O = \pm 10\text{ V}$, $R_L = 2\text{ k}\Omega$	$T_A = 25^\circ\text{C}$	LF15x, LF25x, LF356B	50	200	V/mV
			LF35x	25	200	
	Over temperature		LF15x, LF25x, LF356B	25		
			LF35x	15		
V_O Output voltage swing	$V_S = \pm 15\text{ V}$, $R_L = 10\text{ k}\Omega$		LF15x, LF25x, LF356B, LF35x	± 12	± 13	V
	$V_S = \pm 15\text{ V}$, $R_L = 2\text{ k}\Omega$		LF15x, LF25x, LF356B, LF35x	± 10	± 12	

(1) Unless otherwise stated, these test conditions apply:

	LF15x	LF25x	LF356B	LF35x
Supply Voltage, V_S	$\pm 15\text{ V} \leq V_S \leq \pm 20\text{ V}$	$\pm 15\text{ V} \leq V_S \leq \pm 20\text{ V}$	$\pm 15\text{ V} \leq V_S \leq \pm 20\text{ V}$	$V_S = \pm 15\text{ V}$
T_A	$-55^\circ\text{C} \leq T_A \leq +125^\circ\text{C}$	$-25^\circ\text{C} \leq T_A \leq +85^\circ\text{C}$	$0^\circ\text{C} \leq T_A \leq +70^\circ\text{C}$	$0^\circ\text{C} \leq T_A \leq +70^\circ\text{C}$
T_{HIGH}	$+125^\circ\text{C}$	$+85^\circ\text{C}$	$+70^\circ\text{C}$	$+70^\circ\text{C}$

and V_{OS} , I_B and I_{OS} are measured at $V_{CM} = 0$.

- The Temperature Coefficient of the adjusted input offset voltage changes only a small amount ($0.5\ \mu\text{V}/^\circ\text{C}$ typically) for each mV of adjustment from its original unadjusted value. Common-mode rejection and open-loop voltage gain are also unaffected by offset adjustment.
- The input bias currents are junction leakage currents which approximately double for every 10°C increase in the junction temperature, T_J . Due to limited production test time, the input bias currents measured are correlated to junction temperature. In normal operation the junction temperature rises above the ambient temperature as a result of internal power dissipation, P_d . $T_J = T_A + \theta_{JA} P_d$ where θ_{JA} is the thermal resistance from junction to ambient. Use of a heat sink is recommended if input bias current is to be kept to a minimum.

DC Electrical Characteristics (continued)

See ⁽¹⁾

PARAMETER		TEST CONDITIONS		MIN	TYP	MAX	UNIT	
V _{CM}	Input common-mode voltage range	V _S = ±15 V	V _{CM, High}	LF15x, LF25x, LF356B	11	15.1	V	
				LF35x	10	15.1		
			V _{CM, Low}	LF15x, LF25x, LF356B		-12		-11
				LF35x		-12		-10
CMRR	Common-mode rejection ratio	LF15x, LF25x, LF356B		85	100	dB		
		LF35x		80	100			
PSRR	Supply voltage rejection ratio ⁽⁴⁾	LF15x, LF25x, LF356B		85	100	dB		
		LF35x		80	100			

(4) Supply Voltage Rejection is measured for both supply magnitudes increasing or decreasing simultaneously, in accordance with common practice.

6.8 Power Dissipation Ratings

			MIN	MAX	UNIT
Power Dissipation at T _A = 25°C ⁽¹⁾ ⁽²⁾	LMC Package (Still Air)	LF15x		560	mW
		LF25x, LF356B, LF35x		400	
	LMC Package (400 LF/Min Air Flow)	LF15x		1200	
		LF25x, LF356B, LF35x		1000	
	P Package	LF25x, LF356B, LF35x		670	
	D Package	LF25x, LF356B, LF35x		380	

- (1) The maximum power dissipation for these devices must be derated at elevated temperatures and is dictated by T_{JMAX}, θ_{JA}, and the ambient temperature, T_A. The maximum available power dissipation at any temperature is P_D = (T_{JMAX} - T_A) / θ_{JA} or the 25°C P_{DMAX}, whichever is less.
- (2) Maximum power dissipation is defined by the package characteristics. Operating the part near the maximum power dissipation may cause the part to operate outside specified limits.

6.9 Typical Characteristics

6.9.1 Typical DC Performance Characteristics

Curves are for LF155 and LF156 unless otherwise specified.

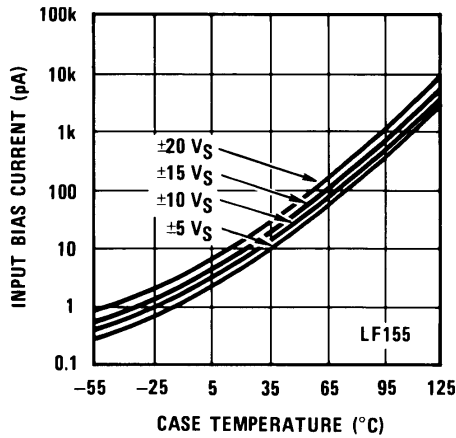

Figure 1. Input Bias Current

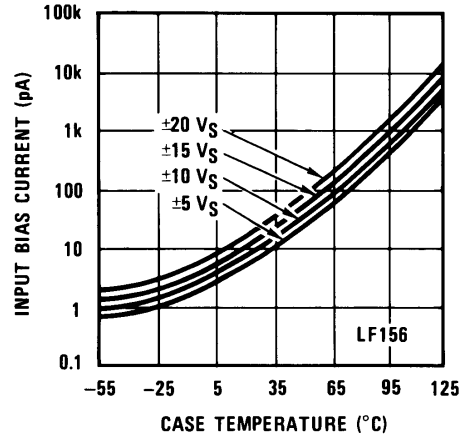

Figure 2. Input Bias Current

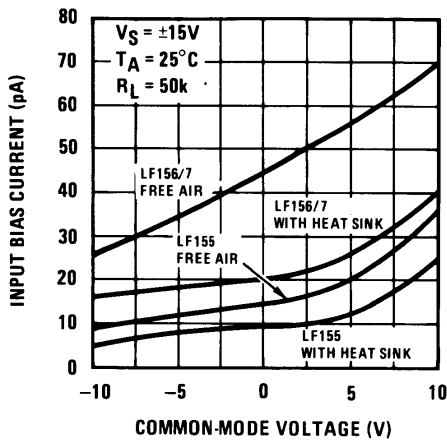

Figure 3. Input Bias Current

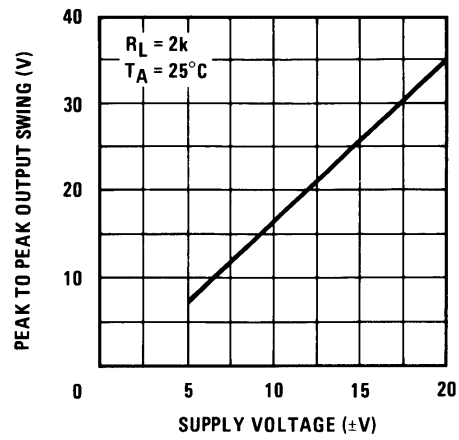

Figure 4. Voltage Swing

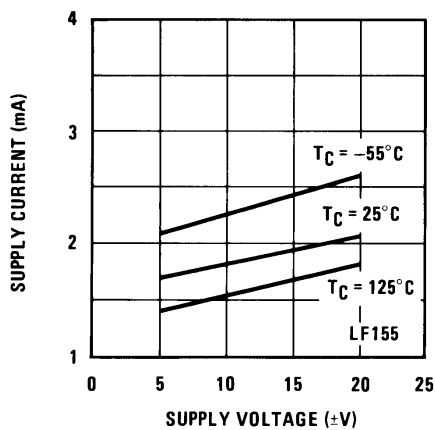

Figure 5. Supply Current

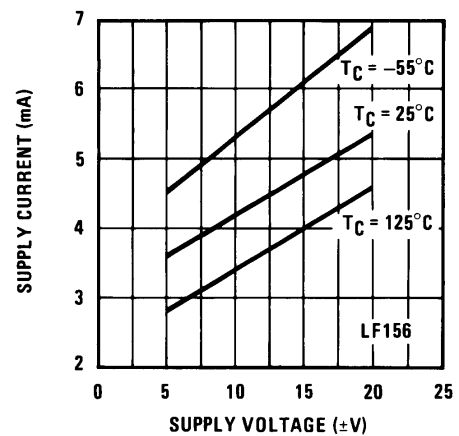

Figure 6. Supply Current

Typical DC Performance Characteristics (continued)

Curves are for LF155 and LF156 unless otherwise specified.

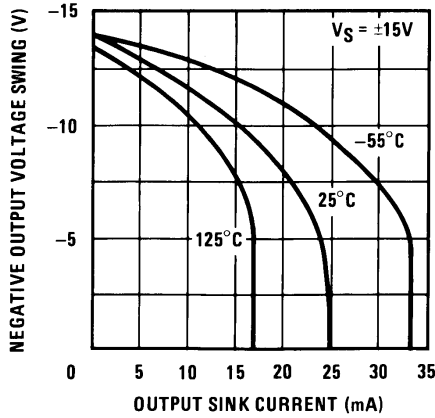

Figure 7. Negative Current Limit

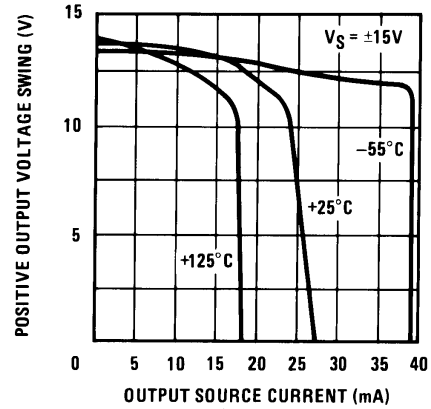

Figure 8. Positive Current Limit

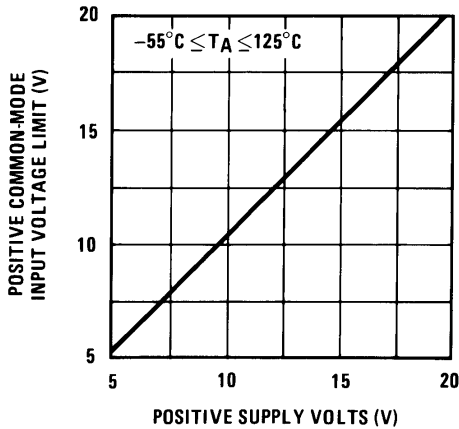

Figure 9. Positive Common-Mode Input Voltage Limit

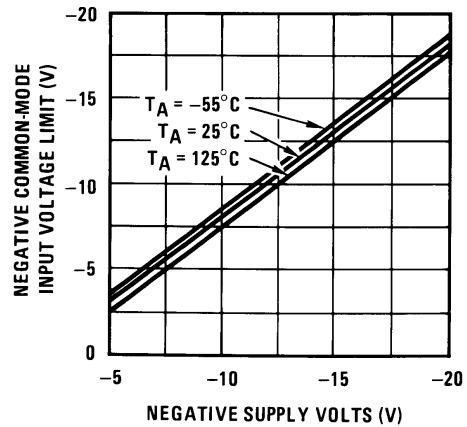

Figure 10. Negative Common-Mode Input Voltage Limit

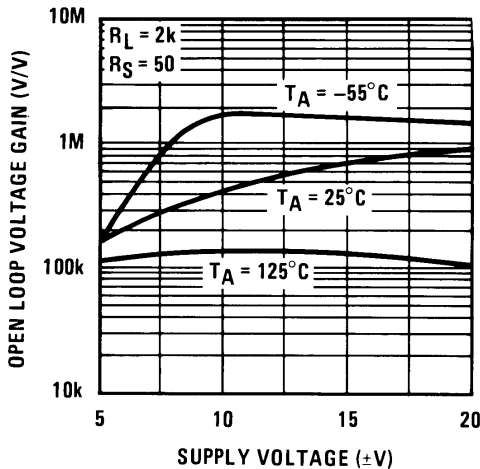

Figure 11. Open-Loop Voltage Gain

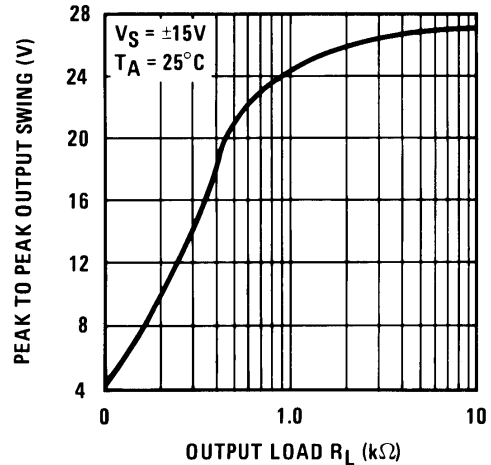

Figure 12. Output Voltage Swing

6.9.2 Typical AC Performance Characteristics

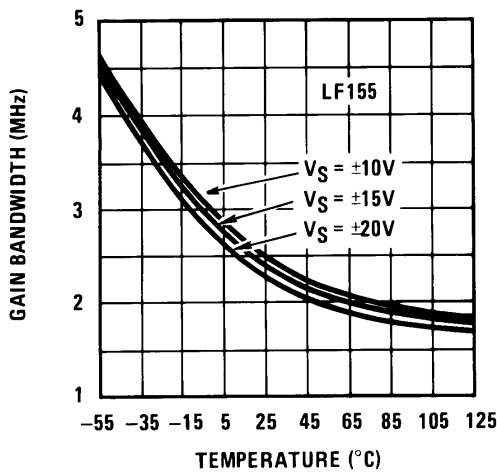

Figure 13. Gain Bandwidth

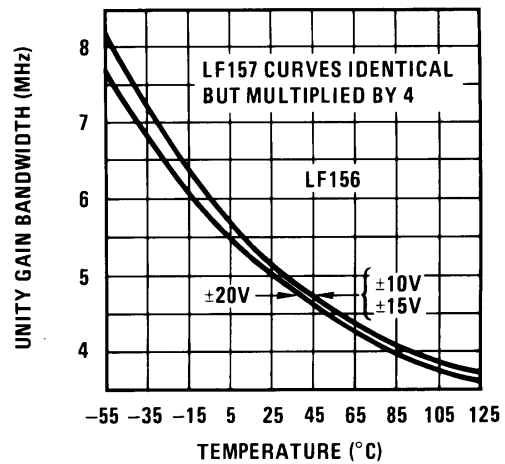

Figure 14. Gain Bandwidth

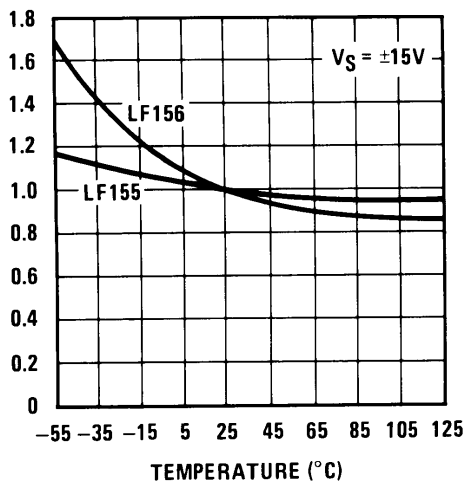

Figure 15. Normalized Slew Rate

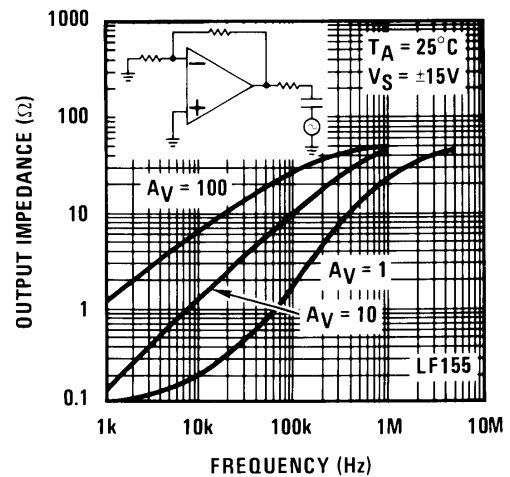

Figure 16. Output Impedance

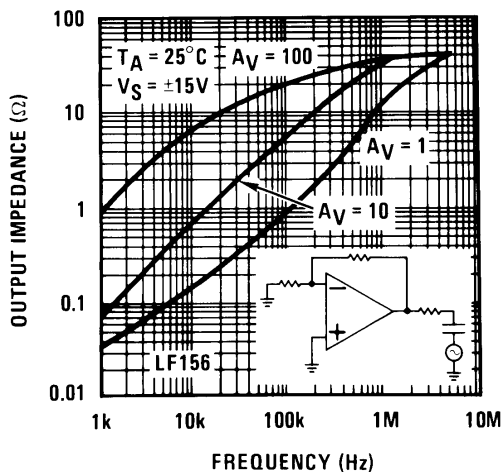

Figure 17. Output Impedance

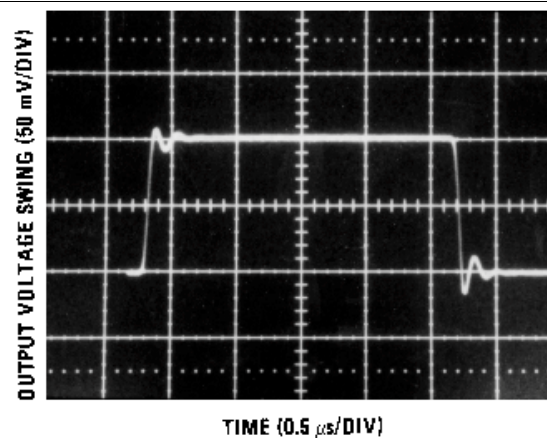

Figure 18. LF155 Small Signal Pulse Response, $A_V = +1$

Typical AC Performance Characteristics (continued)

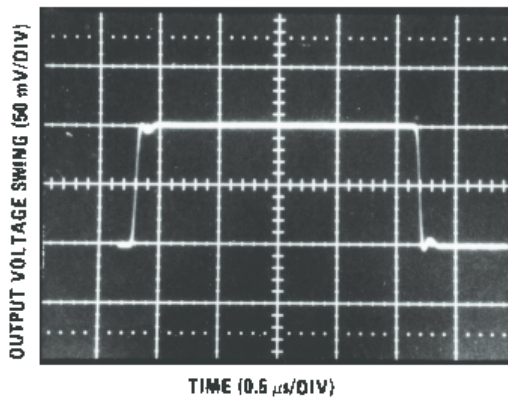

Figure 19. LF156 Small Signal Pulse Response, $A_V = +1$

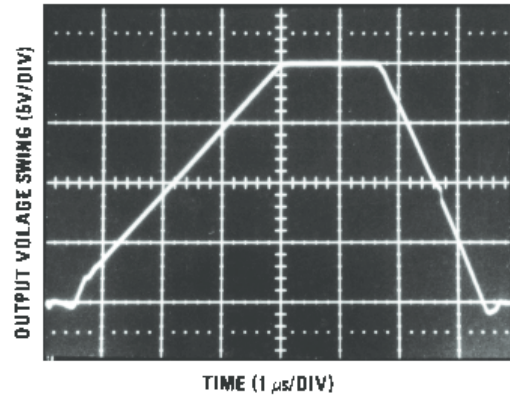

Figure 20. LF155 Large Signal Pulse Response, $A_V = +1$

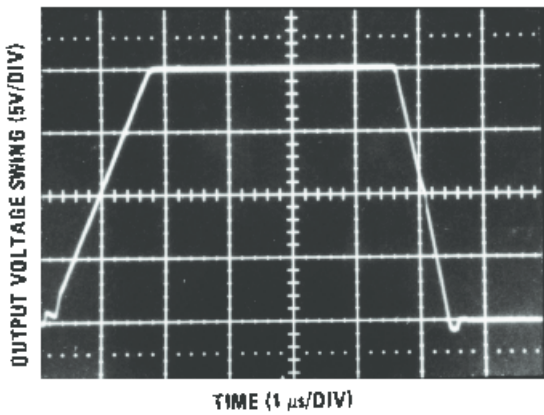

Figure 21. LF156 Large Signal Puls Response, $A_V = +1$

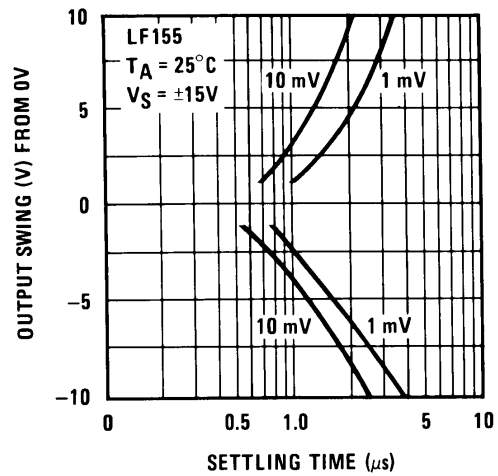

Figure 22. Inverter Settling Time

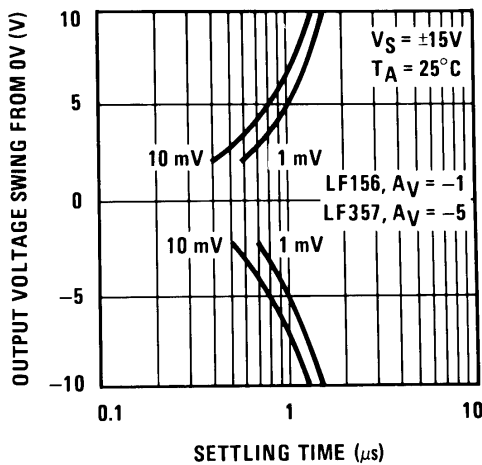

Figure 23. Inverter Settling Time

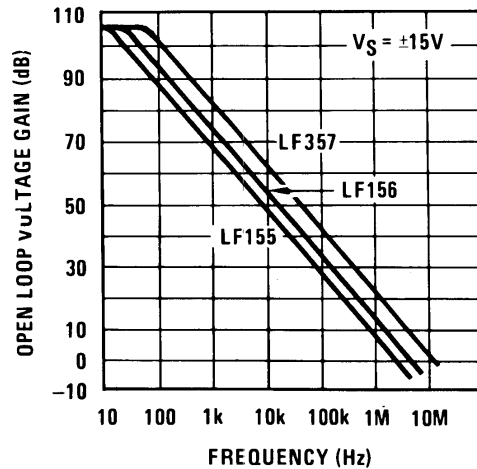
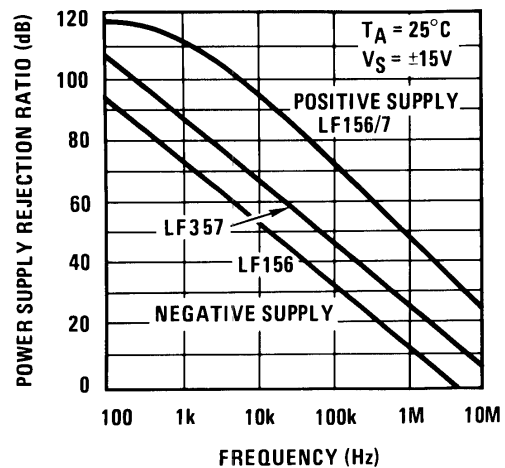
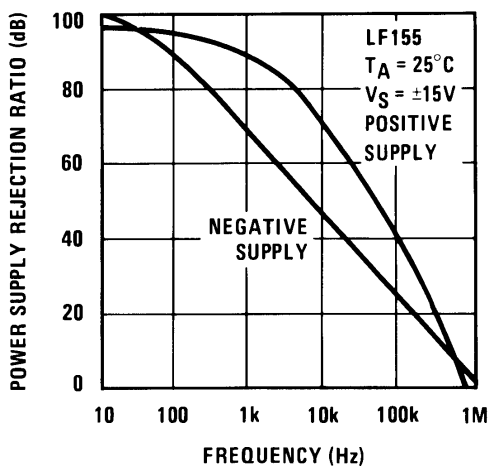
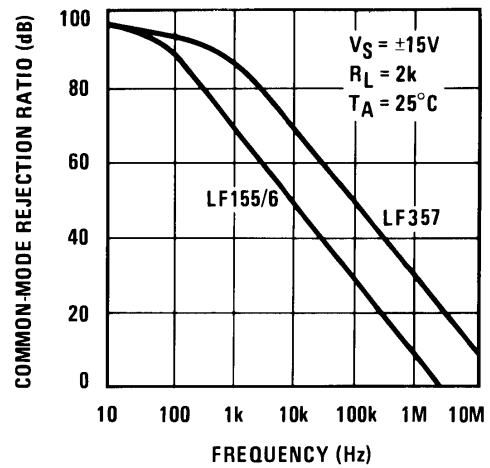
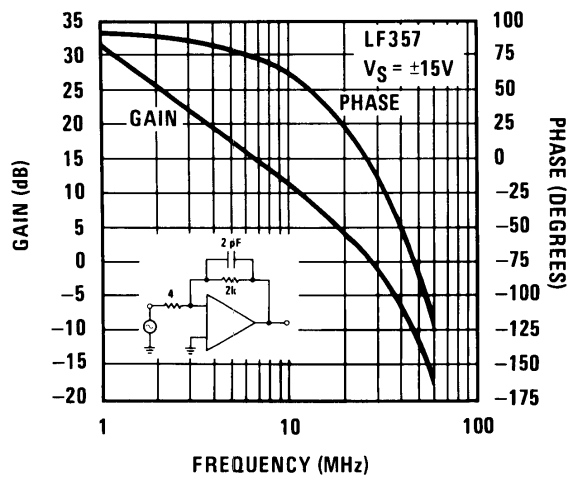
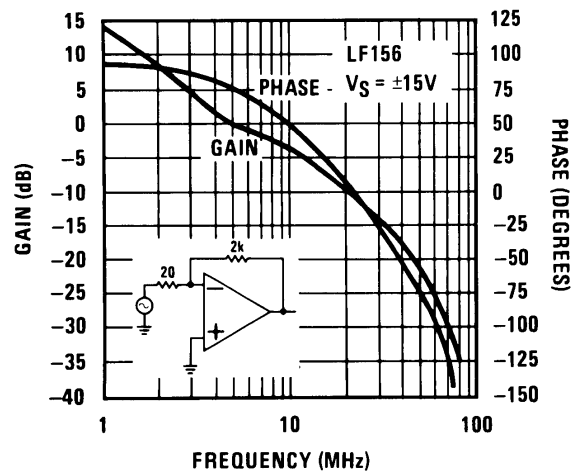
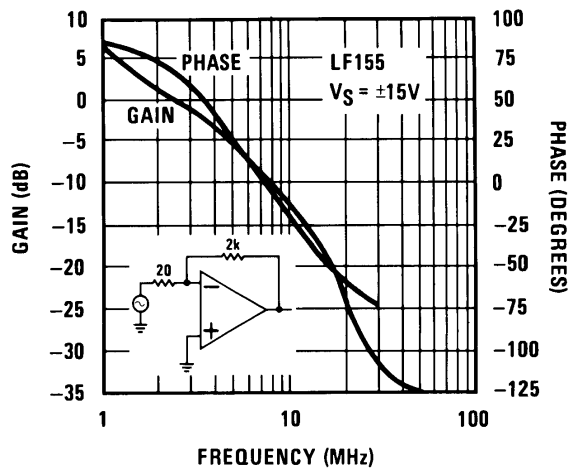
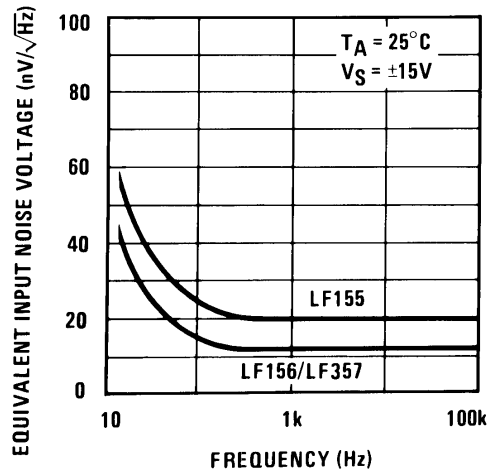
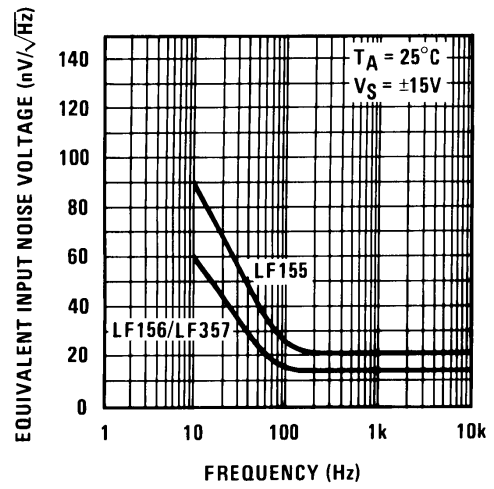
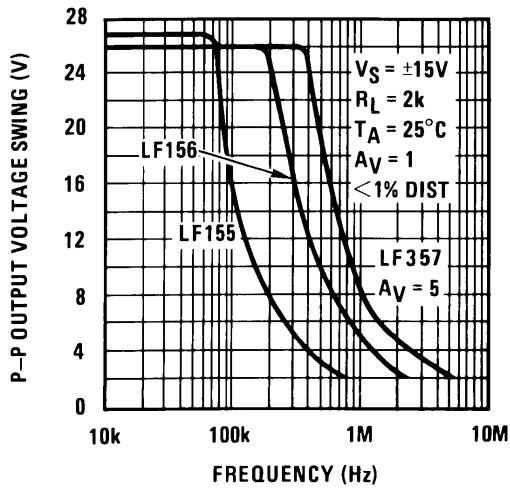

Figure 24. Open-Loop Frequency Response

Typical AC Performance Characteristics (continued)



Typical AC Performance Characteristics (continued)



7 Detailed Description

7.1 Overview

These are the first monolithic JFET input operational amplifiers to incorporate well matched, high voltage JFETs on the same chip with standard bipolar transistors (BI-FET Technology). These amplifiers feature low input bias and offset currents, as well as low offset voltage and offset voltage drift, coupled with offset adjust which does not degrade drift or common-mode rejection. These devices can replace expensive hybrid and module FET operational amplifiers. Designed for low voltage and current noise and a low 1/f noise corner, these devices are excellent for low noise applications using either high or low source impedance.

7.2 Functional Block Diagram

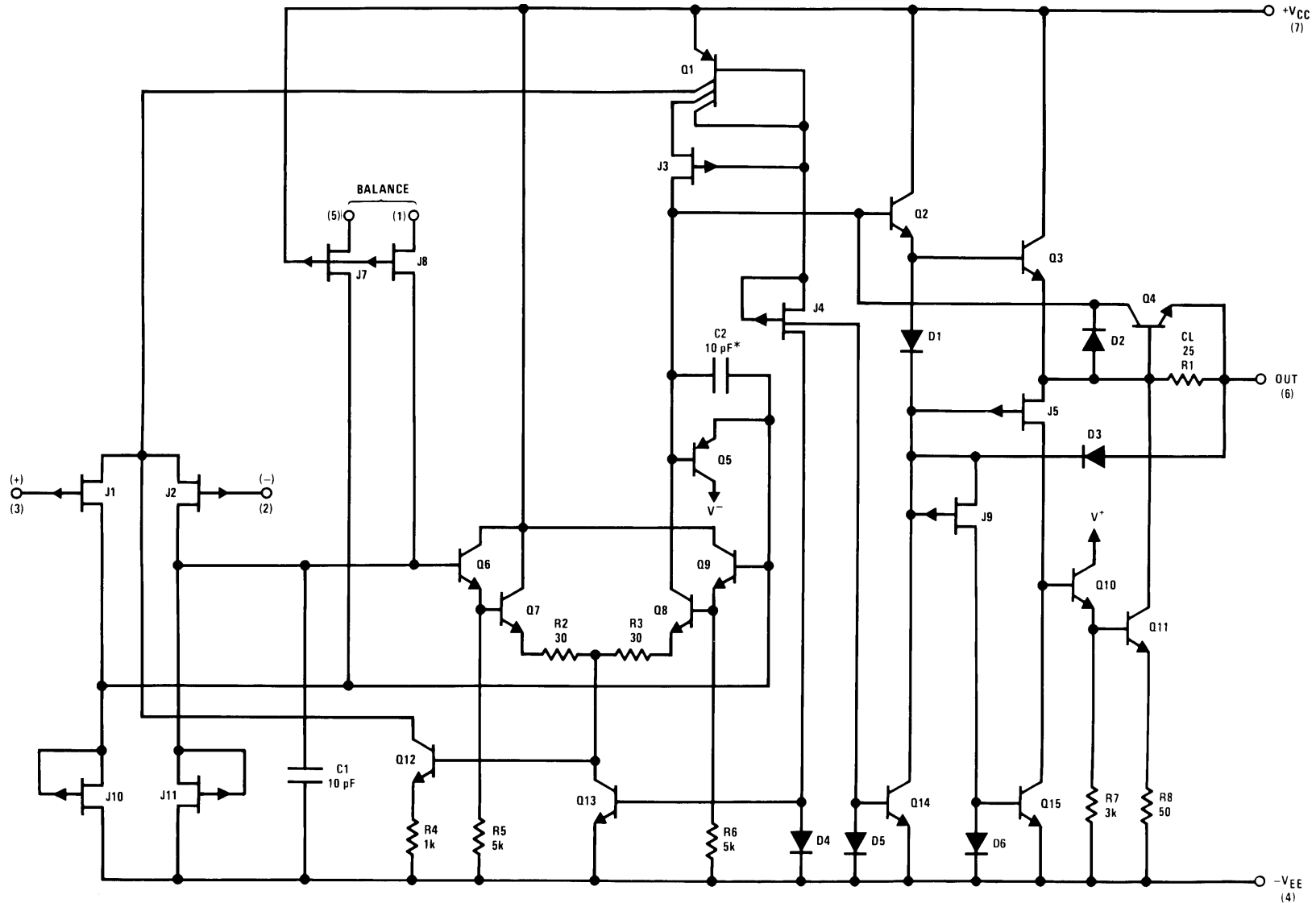

*C = 3 pF in LF357 series.

Figure 34. Detailed Schematic

7.3 Feature Description

7.3.1 Large Differential Input Voltage

These are operational amplifiers with JFET input devices. These JFETs have large reverse breakdown voltages from gate to source and drain eliminating the need for clamps across the inputs. Therefore large differential input voltages can easily be accommodated without a large increase in input current. The maximum differential input voltage is independent of the supply voltages. However, neither of the input voltages should be allowed to exceed the negative supply as this will cause large currents to flow which can result in a destroyed unit.

7.3.2 Large Common-Mode Input Voltage

These amplifiers will operate with the common-mode input voltage equal to the positive supply. In fact, the common-mode voltage can exceed the positive supply by approximately 100 mV independent of supply voltage and over the full operating temperature range. The positive supply can therefore be used as a reference on an input as, for example, in a supply current monitor and/or limiter.

7.4 Device Functional Modes

The LFx5x has a single functional mode and operates according to the conditions listed in the [Recommended Operating Conditions](#).

8 Application and Implementation

NOTE

Information in the following applications sections is not part of the TI component specification, and TI does not warrant its accuracy or completeness. TI's customers are responsible for determining suitability of components for their purposes. Customers should validate and test their design implementation to confirm system functionality.

8.1 Application Information

These are op amps with JFET input devices. These JFETs have large reverse breakdown voltages from gate to source and drain eliminating the need for clamps across the inputs. Therefore large differential input voltages can easily be accommodated without a large increase in input current. The maximum differential input voltage is independent of the supply voltages. However, neither of the input voltages should be allowed to exceed the negative supply as this will cause large currents to flow which can result in a destroyed unit.

Exceeding the negative common-mode limit on either input will force the output to a high state, potentially causing a reversal of phase to the output. Exceeding the negative common-mode limit on both inputs will force the amplifier output to a high state. In neither case does a latch occur since raising the input back within the common-mode range again puts the input stage and thus the amplifier in a normal operating mode.

Exceeding the positive common-mode limit on a single input will not change the phase of the output however, if both inputs exceed the limit, the output of the amplifier will be forced to a high state.

These amplifiers will operate with the common-mode input voltage equal to the positive supply. In fact, the common-mode voltage can exceed the positive supply by approximately 100 mV independent of supply voltage and over the full operating temperature range. The positive supply can therefore be used as a reference on an input as, for example, in a supply current monitor and/or limiter.

Precautions should be taken to ensure that the power supply for the integrated circuit never becomes reversed in polarity or that the unit is not inadvertently installed backwards in a socket as an unlimited current surge through the resulting forward diode within the IC could cause fusing of the internal conductors and result in a destroyed unit.

All of the bias currents in these amplifiers are set by FET current sources. The drain currents for the amplifiers are therefore essentially independent of supply voltage.

As with most amplifiers, care should be taken with lead dress, component placement and supply decoupling in order to ensure stability. For example, resistors from the output to an input should be placed with the body close to the input to minimize pick-up and maximize the frequency of the feedback pole by minimizing the capacitance from the input to ground.

A feedback pole is created when the feedback around any amplifier is resistive. The parallel resistance and capacitance from the input of the device (usually the inverting input) to AC ground set the frequency of the pole. In many instances the frequency of this pole is much greater than the expected 3-dB frequency of the closed loop gain and consequently there is negligible effect on stability margin. However, if the feedback pole is less than approximately six times the expected 3-dB frequency a lead capacitor should be placed from the output to the input of the op amp. The value of the added capacitor should be such that the RC time constant of this capacitor and the resistance it parallels is greater than or equal to the original feedback pole time constant.

8.2 Typical Application

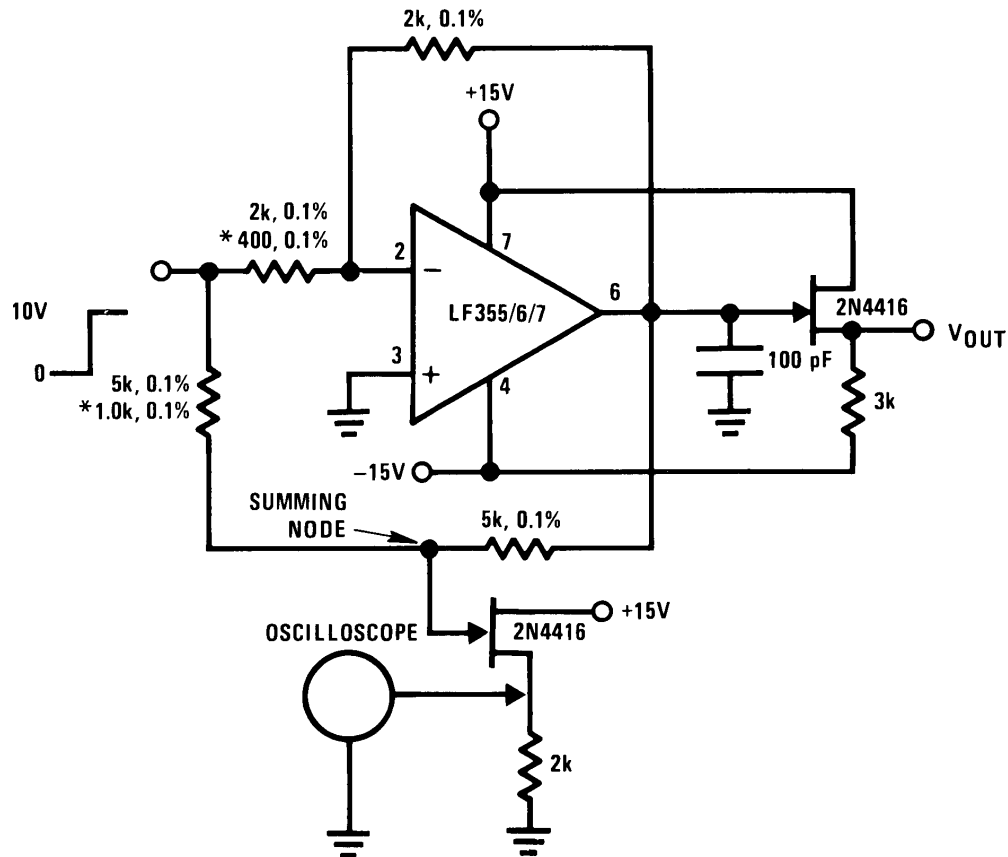

Figure 35. Settling Time Test Circuit

8.2.1 Design Requirements

Settling time is tested with the LF35x connected as unity gain inverter and LF357 connected for $A_V = -5$

8.2.2 Detailed Design Procedure

Connect the circuit components as shown in [Figure 35](#). In particular, use FET to isolate the probe capacitance.

Apply a 10-V step function to the input.

Use an oscilloscope to probe the circuit as shown in [Figure 35](#).

Typical Application (continued)

8.2.3 Application Curves

Large Signal Inverter Output, V_{OUT} (from Settling Time Circuit)

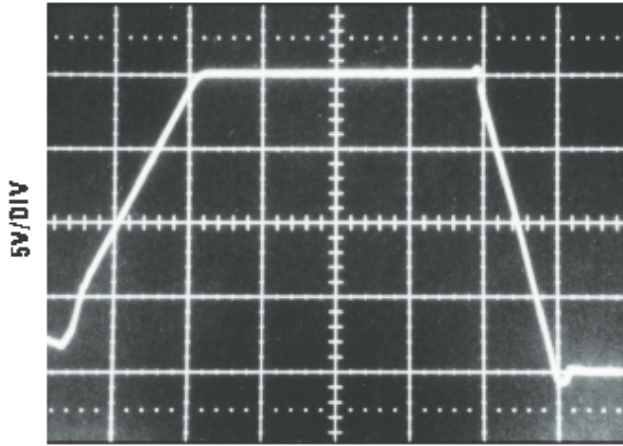

2 μ s/DIV

Figure 36. LF355

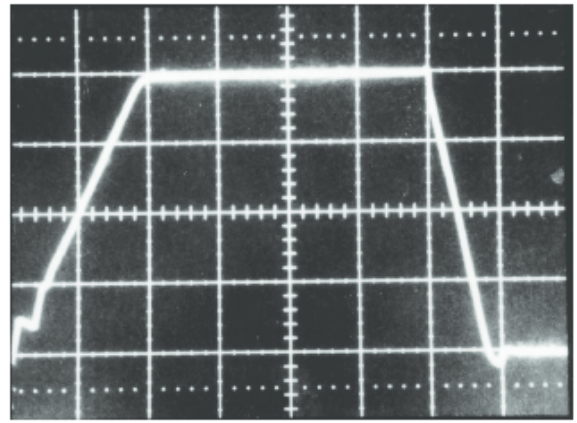

1 μ s/DIV

Figure 37. LF356

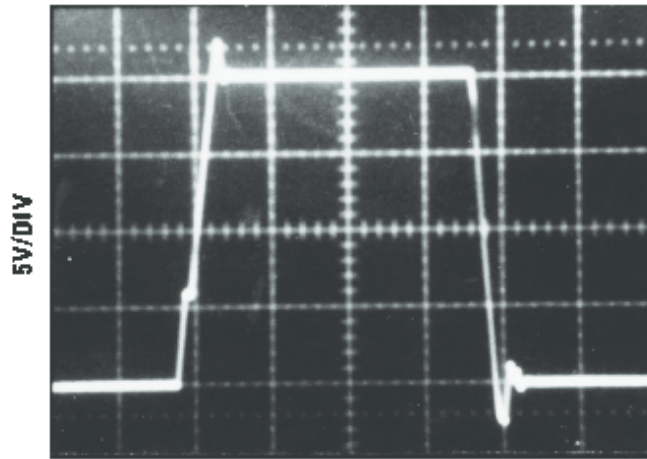

1 μ s/DIV

Figure 38. LF357

8.3 System Examples

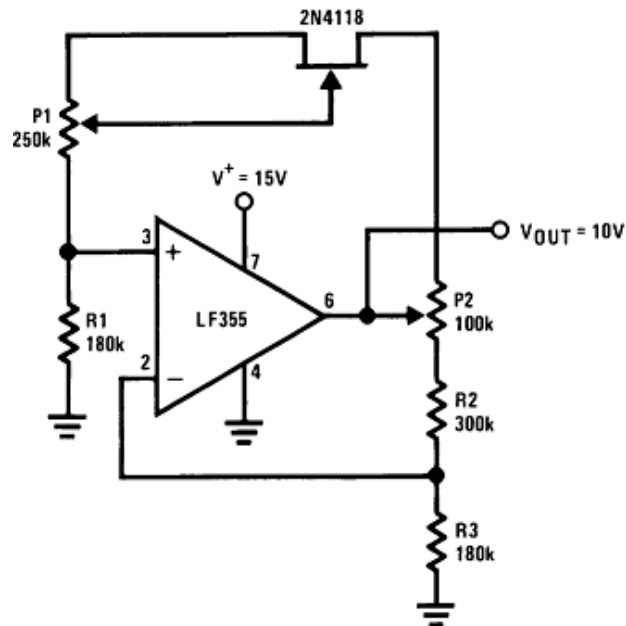

Figure 39. Low Drift Adjustable Voltage Reference

- $\Delta V_{OUT} / \Delta T = \pm 0.002\%/^{\circ}\text{C}$
- All resistors and potentiometers should be wire-wound
- P1: drift adjust
- P2: V_{OUT} adjust
- Use LF155 for
 - Low I_B
 - Low drift
 - Low supply current

System Examples (continued)

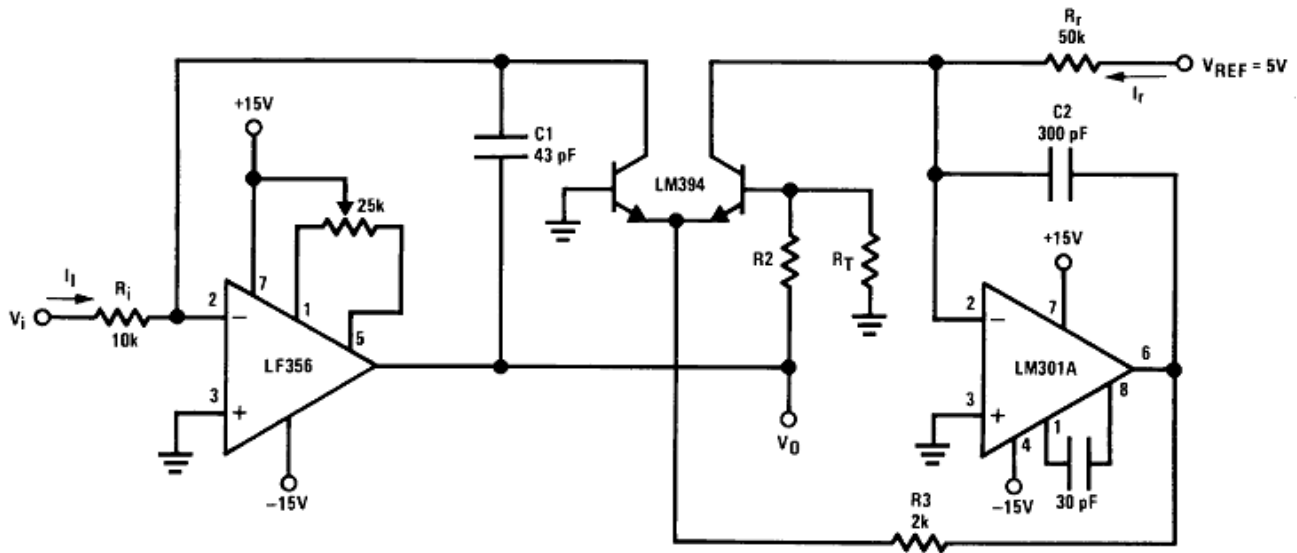

Figure 40. Fast Logarithmic Converter

- Dynamic range: $100 \mu\text{A} \leq I_i \leq 1 \text{ mA}$ (5 decades), $|V_O| = 1 \text{ V/decade}$
- Transient response: $3 \mu\text{s}$ for $\Delta I_i = 1 \text{ decade}$
- C1, C2, R2, R3: added dynamic compensation
- V_{OS} adjust the LF156 to minimize quiescent error
- R_T : Tel Labs type Q81 + 0.3%/°C

$$|V_{OUT}| = \left[1 + \frac{R_2}{R_T} \right] \frac{kT}{q} \ln V_i \left[\frac{R_f}{V_{REF} R_i} \right] = \log V_i \frac{1}{R_i I_f} \quad R_2 = 15.7\text{k}, R_T = 1\text{k}, 0.3\%/^{\circ}\text{C} \quad (1)$$

System Examples (continued)

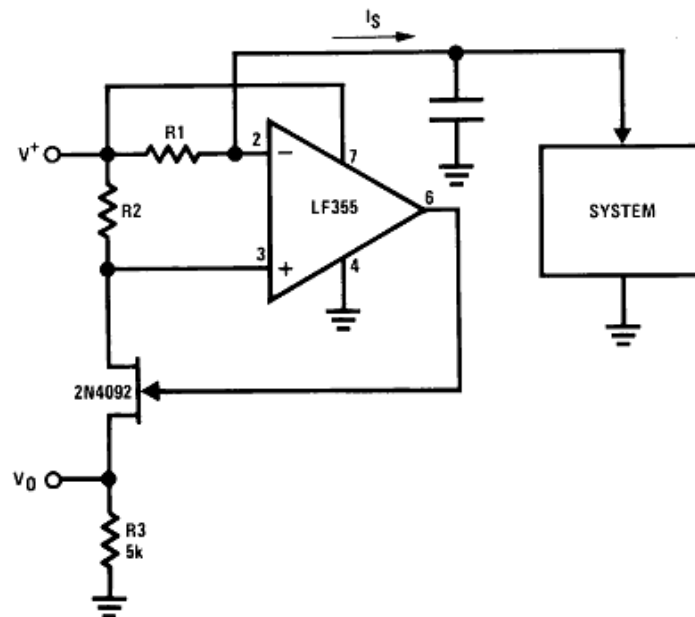

Figure 41. Precision Current Monitor

- $V_O = 5 R1/R2$ (V/mA of I_S)
- R1, R2, R3: 0.1% resistors
- Use LF155 for
 - Common-mode range to supply range
 - Low I_B
 - Low V_{OS}
 - Low Supply Current

System Examples (continued)

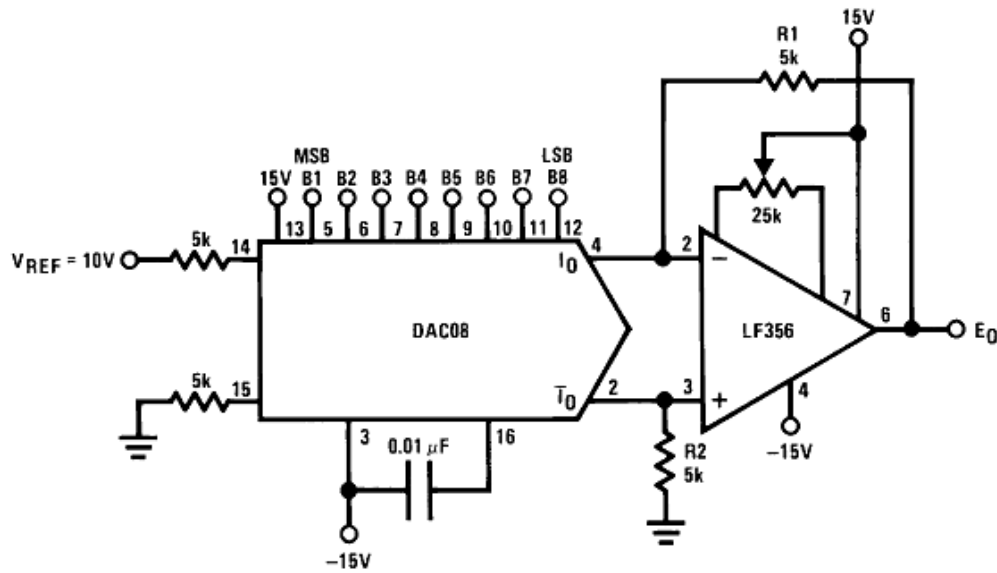

Figure 42. 8-Bit D/A Converter With Symmetrical Offset Binary Operation

- R1, R2 should be matched within ±0.05%
- Full-scale response time: 3 μs

Table 1. Bit Illustration of the 8-Bit D/A Converter

E _O	B1	B2	B3	B4	B5	B6	B7	B8	COMMENTS
+9.920	1	1	1	1	1	1	1	1	Positive Full-Scale
+0.040	1	0	0	0	0	0	0	0	(+) Zero-Scale
-0.040	0	1	1	1	1	1	1	1	(-) Zero-Scale
-9.920	0	0	0	0	0	0	0	0	Negative Full-Scale

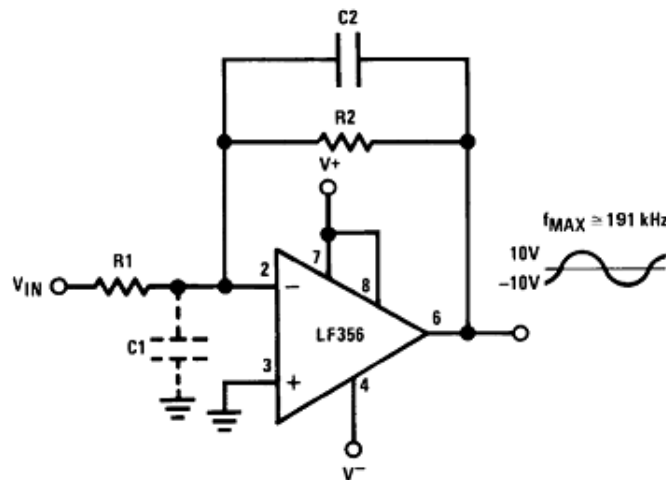

Figure 43. Wide BW Low Noise, Low Drift Amplifier

• Power BW: $f_{MAX} = \frac{S_r}{2\pi V_p} \cong 191 \text{ kHz}$

(2)

Parasitic input capacitance $C_1 \approx (3 \text{ pF for LF155, LF156 and LF357 plus any additional layout capacitance})$ interacts with feedback elements and creates undesirable high frequency pole. To compensate add C_2 such that: $R_2 C_2 \approx R_1 C_1$.

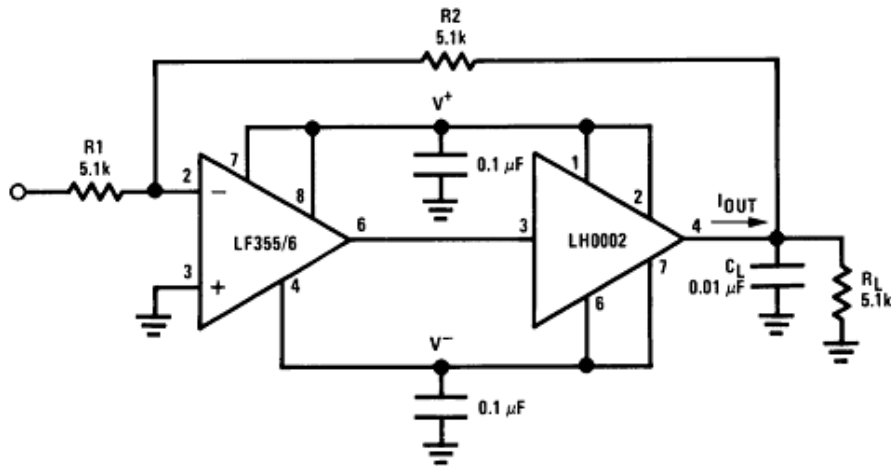

Figure 44. Boosting the LF156 With a Current Amplifier

- $I_{OUT(MAX)} \approx 150 \text{ mA}$ (will drive $R_L \geq 100 \Omega$)
 - $\frac{\Delta V_{OUT}}{\Delta T} = \frac{0.15}{10^{-2}} \text{ V}/\mu\text{s}$ (with C_L shown)
 - No additional phase shift added by the current amplifier
- (3)

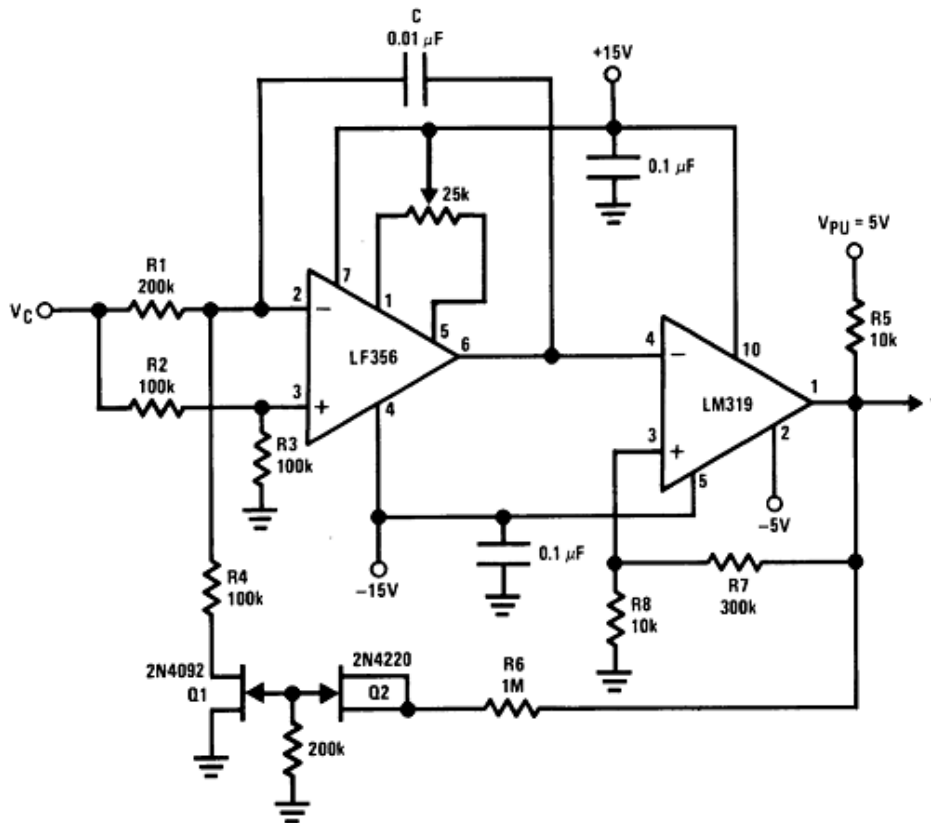

Figure 45. Decades VCO

R1, R4 matched. Linearity 0.1% over 2 decades.

$$f = \frac{V_C (R8 + R7)}{(8 V_{PU} R8 R1) C'} \quad 0 \leq V_C \leq 30V, 10 \text{ Hz} \leq f \leq 10 \text{ kHz} \quad (4)$$

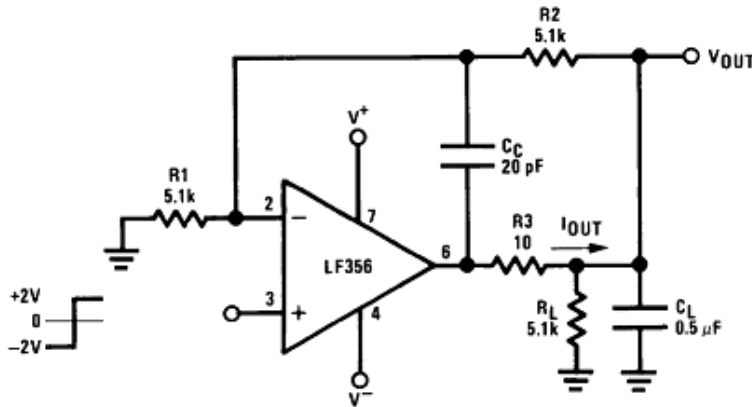

Figure 46. Isolating Large Capacitive Loads

- Overshoot 6%
- t_s 10 μs
- When driving large C_L , the V_{OUT} slew rate determined by C_L and $I_{OUT(MAX)}$:

$$\frac{\Delta V_{OUT}}{\Delta T} = \frac{I_{OUT}}{C_L} \cong \frac{0.02}{0.5} V/\mu s = 0.04 V/\mu s \text{ (with } C_L \text{ shown)} \quad (5)$$

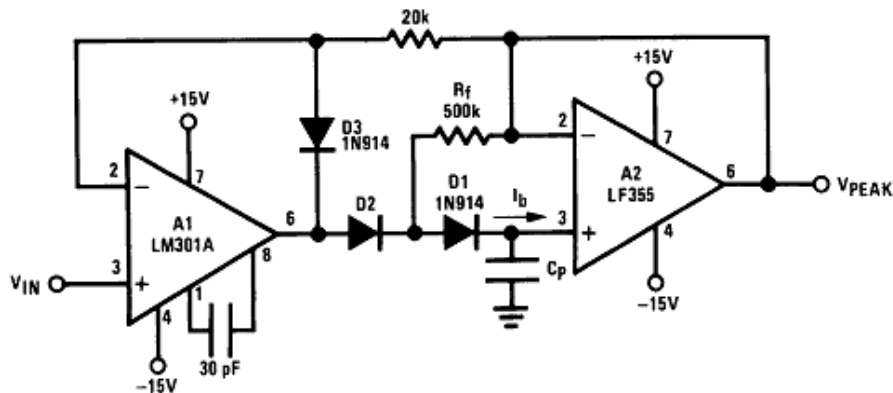

Figure 47. Low Drift Peak Detector

- By adding D1 and R_f , $V_{D1} = 0$ during hold mode. Leakage of D2 provided by feedback path through R_f .
- Leakage of circuit is essentially I_b (LF155, LF156) plus capacitor leakage of C_p .
- Diode D3 clamps V_{OUT} (A1) to $V_{IN} - V_{D3}$ to improve speed and to limit reverse bias of D2.
- Maximum input frequency should be $\ll \frac{1}{2\pi R_f C_{D2}}$ where C_{D2} is the shunt capacitance of D2.

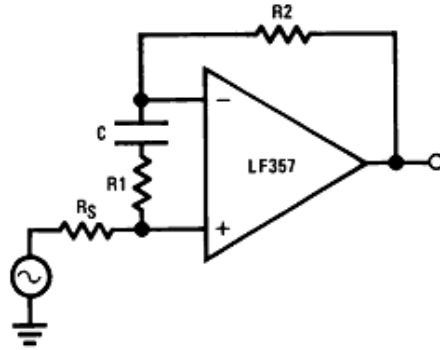

Figure 48. Noninverting Unity Gain Operation for LF157

$$R_1 C \geq \frac{1}{(2\pi)(5 \text{ MHz})}$$

$$R_1 = \frac{R_2 + R_S}{4}$$

$$A_{V(DC)} = 1$$

$$f_{-3 \text{ dB}} \approx 5 \text{ MHz}$$

(6)

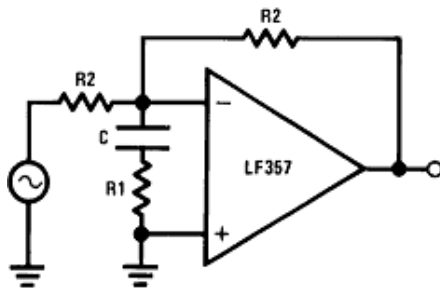

Figure 49. Inverting Unity Gain for LF157

$$R_1 C \geq \frac{1}{(2\pi)(5 \text{ MHz})}$$

$$R_1 = \frac{R_2}{4}$$

$$A_{V(DC)} = -1$$

$$f_{-3 \text{ dB}} \approx 5 \text{ MHz}$$

(7)

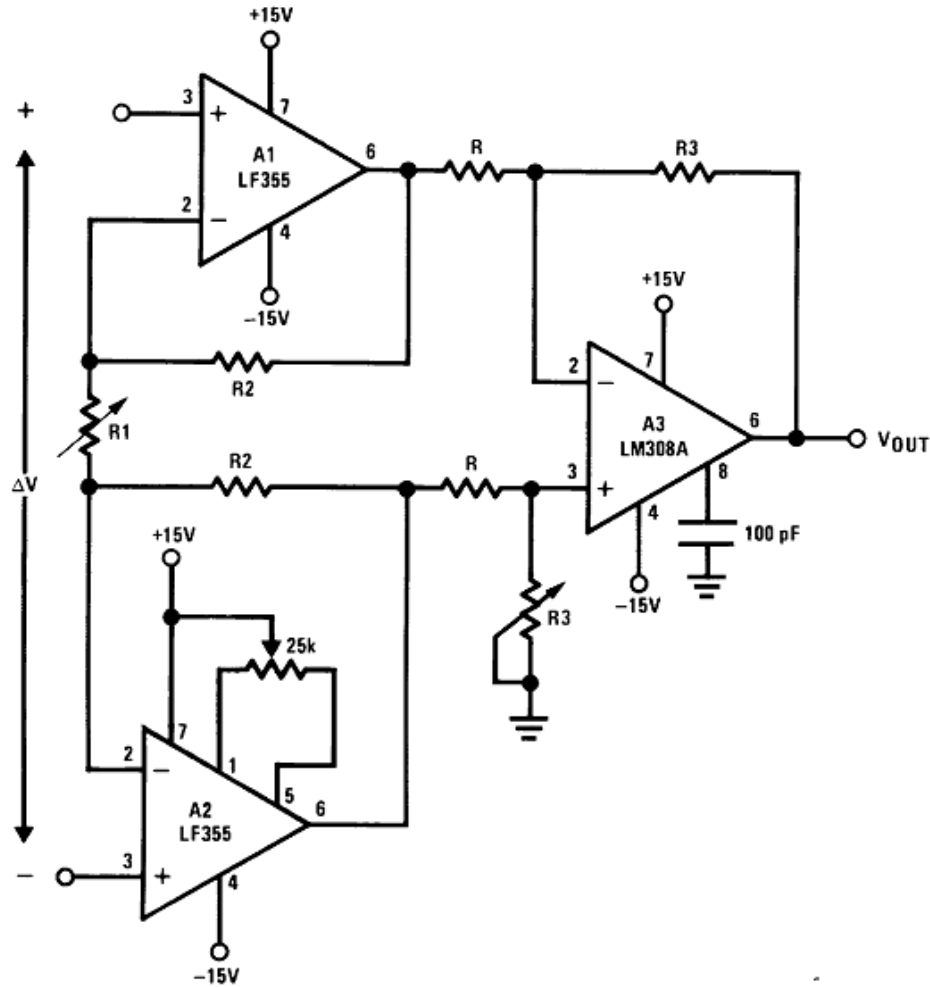

Figure 50. High Impedance, Low Drift Instrumentation Amplifier

- System V_{OS} adjusted via A2 V_{OS} adjust
- Trim R3 to boost up CMRR to 120 dB. Instrumentation amplifier resistor array recommended for best accuracy and lowest drift

$$V_{OUT} = \frac{R3}{R} \left[\frac{2R2}{R1} + 1 \right] \Delta V, V^- + 2V \leq V_{IN \text{ common-mode}} \leq V^+ \quad (8)$$

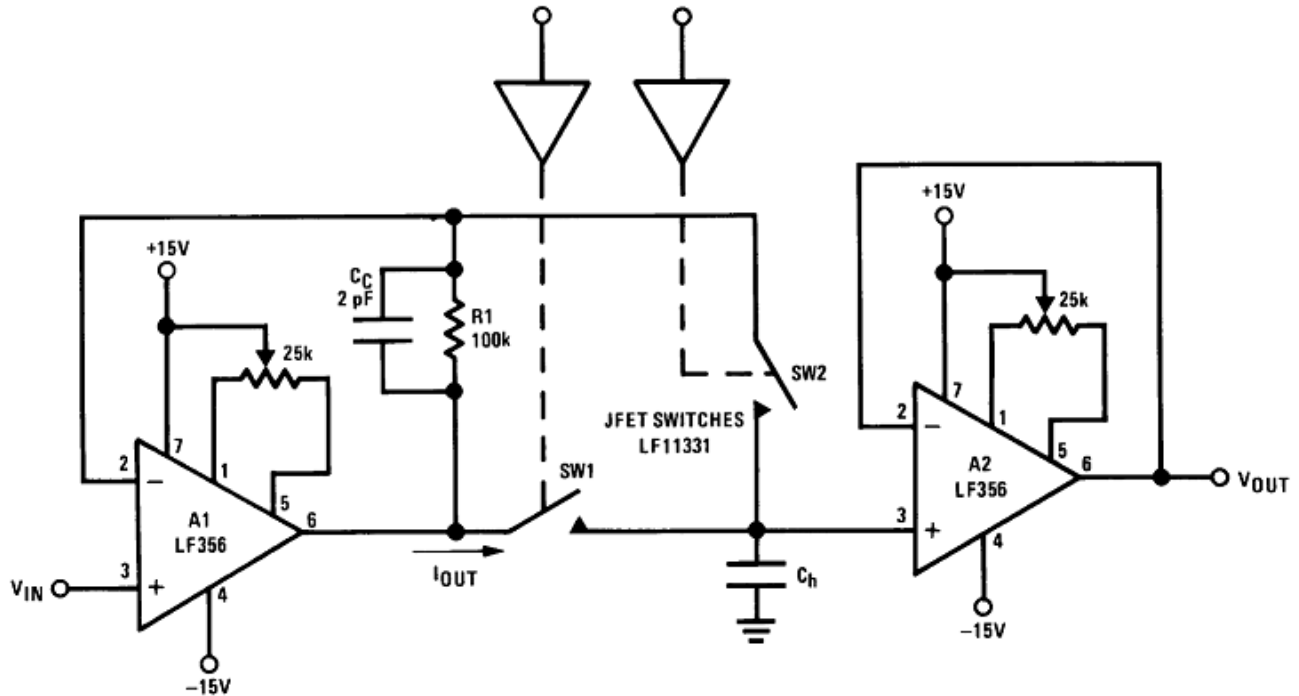

Figure 51. Fast Sample and Hold

- Both amplifiers (A1, A2) have feedback loops individually closed with stable responses (overshoot negligible)
- Acquisition time T_A , estimated by:

$$T_A \cong \left[\frac{2R_{ON} \cdot V_{IN} \cdot C_h}{S_r} \right]^{1/2} \text{ provided that:}$$

$$V_{IN} < 2\pi S_r R_{ON} C_h \text{ and } T_A > \frac{V_{IN} C_h}{I_{OUT(MAX)}}, R_{ON} \text{ is of SW1}$$

$$\text{If inequality not satisfied: } T_A \cong \frac{V_{IN} C_h}{20 \text{ mA}}$$

(9)

- LF156 develops full S_r output capability for $V_{IN} \geq 1 \text{ V}$
- Addition of SW2 improves accuracy by putting the voltage drop across SW1 inside the feedback loop
- Overall accuracy of system determined by the accuracy of both amplifiers, A1 and A2

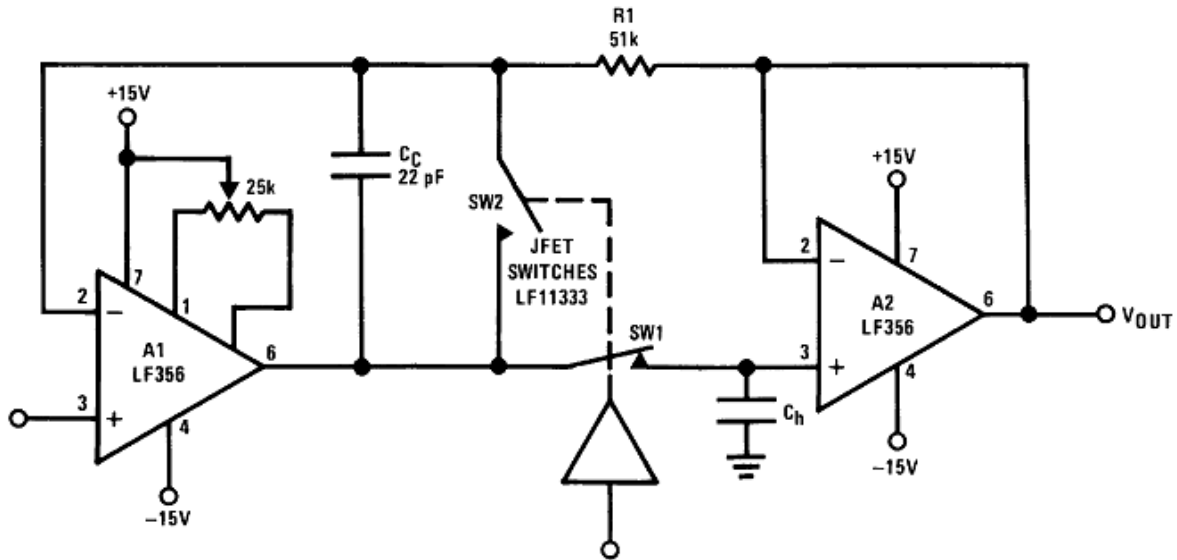

Figure 52. High Accuracy Sample and Hold

- By closing the loop through A2, the V_{OUT} accuracy will be determined uniquely by A1.
 - No V_{OS} adjust required for A2.
- T_A can be estimated by same considerations as previously but, because of the added
 - propagation delay in the feedback loop (A2) the overshoot is not negligible.
- Overall system slower than fast sample and hold
- R1, C_C : additional compensation
- Use LF156 for
 - Fast settling time
 - Low V_{OS}

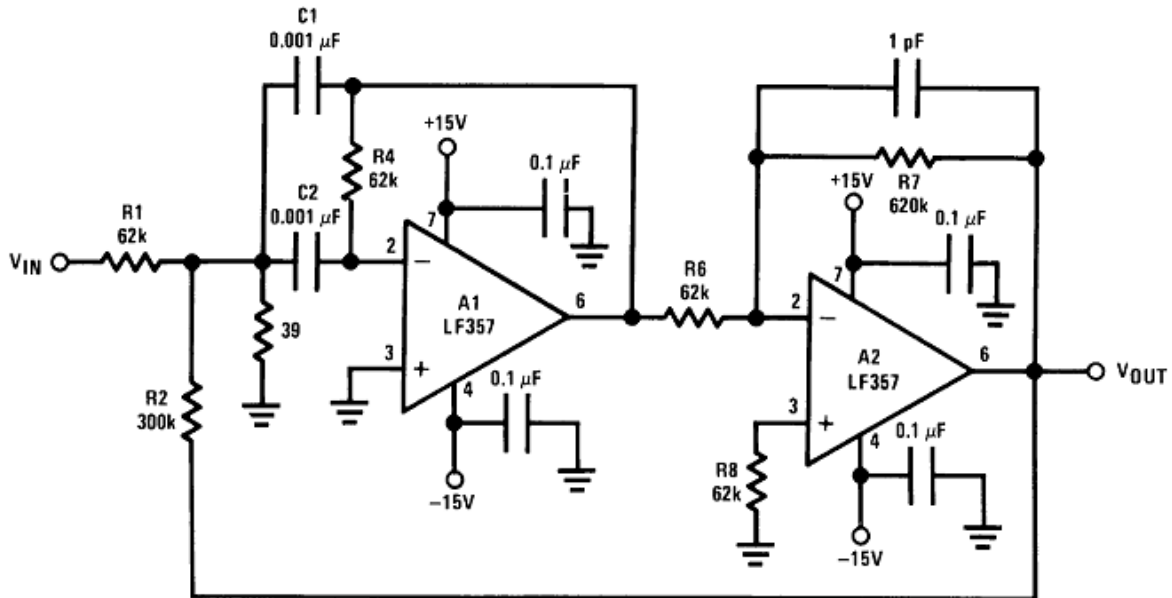

Figure 53. High Q Band Pass Filter

- By adding positive feedback (R2)
- Q increases to 40
- $f_{BP} = 100 \text{ kHz}$

$$\frac{V_{OUT}}{V_{IN}} = 10\sqrt{Q}$$

(10)

- Clean layout recommended
- Response to a 1- V_{p-p} tone burst: 300 μs

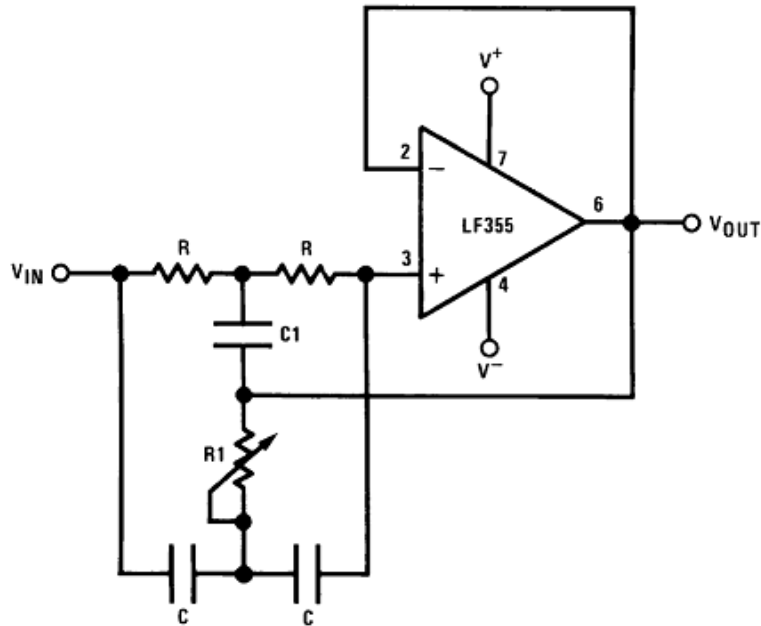

Figure 54. High Q Notch Filter

- $2R1 = R = 10\text{ M}\Omega$
 - $2C = C1 = 300\text{ pF}$
- Capacitors should be matched to obtain high Q
- $f_{\text{NOTCH}} = 120\text{ Hz}$, notch = -55 dB, $Q > 100$
- Use LF155 for
 - Low I_B
 - Low supply current

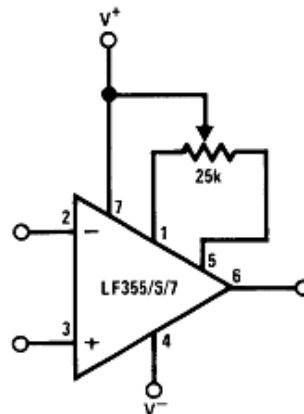

Figure 55. V_{OS} Adjustment

- V_{OS} is adjusted with a 25-k potentiometer
- The potentiometer wiper is connected to V^+
- For potentiometers with temperature coefficient of 100 ppm/°C or less the additional drift with adjust is $\approx 0.5\ \mu\text{V}/^\circ\text{C}/\text{mV}$ of adjustment
- Typical overall drift: $5\ \mu\text{V}/^\circ\text{C} \pm (0.5\ \mu\text{V}/^\circ\text{C}/\text{mV}$ of adj.)

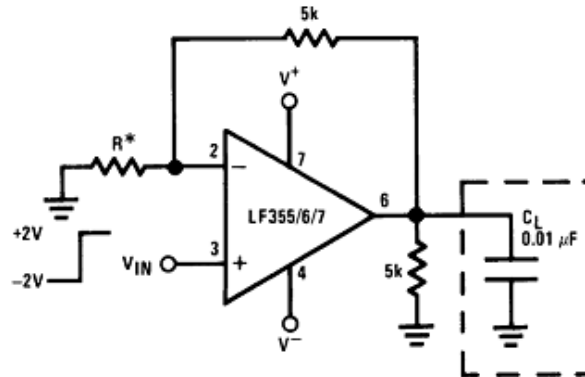

Figure 56. Driving Capacitive Loads

- *LF15x R = 5k, LF357 R = 1.25 k
- Due to a unique output stage design, these amplifiers have the ability to drive large capacitive loads and still maintain stability. $C_{L(MAX)} \approx 0.01 \mu\text{F}$.
- Overshoot $\leq 20\%$, Settling time (t_s) $\approx 5 \mu\text{s}$

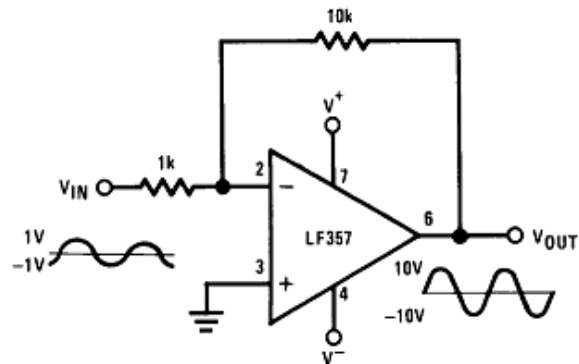

Figure 57. LF357 - A Large Power BW Amplifier

For distortion $\leq 1\%$ and a 20 V_{p-p} V_{OUT} swing, power bandwidth is: 500 kHz.

9 Power Supply Recommendations

See the [Recommended Operating Conditions](#) for the minimum and maximum values for the supply input voltage and operating junction temperature.

10 Layout

10.1 Layout Guidelines

10.1.1 Printed-Circuit-Board Layout For High-Impedance Work

It is generally recognized that any circuit which must operate with less than 1000 pA of leakage current requires special layout of the PCB. When one wishes to take advantage of the low input bias current of the LFX5x, typically less than 30 pA, it is essential to have an excellent layout. Fortunately, the techniques of obtaining low leakages are quite simple. First, the user must not ignore the surface leakage of the PCB, even though it may sometimes appear acceptably low, because under conditions of high humidity or dust or contamination, the surface leakage will be appreciable.

To minimize the effect of any surface leakage, lay out a ring of foil completely surrounding the inputs of the LFX5x and the terminals of capacitors, diodes, conductors, resistors, relay terminals, and so forth, connected to the inputs of the op amp, as in [Figure 62](#). To have a significant effect, guard rings must be placed on both the top and bottom of the PCB. This PC foil must then be connected to a voltage that is at the same voltage as the amplifier inputs, because no leakage current can flow between two points at the same potential. For example, a PCB trace-to-pad resistance of 10 TΩ, which is normally considered a very large resistance, could leak 5 pA if the trace were a 5-V bus adjacent to the pad of the input. If a guard ring is used and held close to the potential of the amplifier inputs, it will significantly reduce this leakage current.

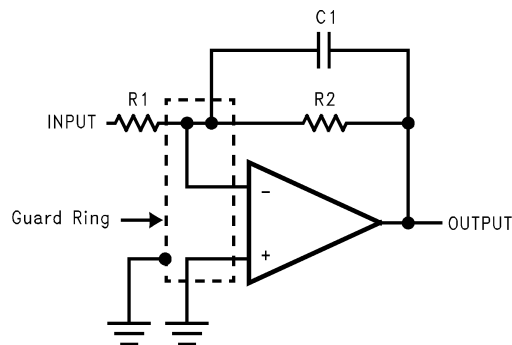

Figure 58. Inverting Amplifier

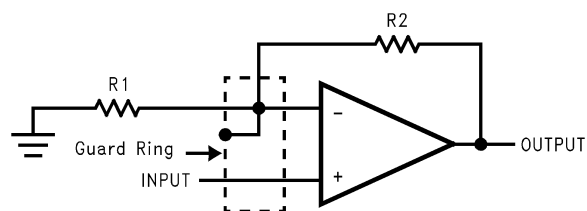

Figure 59. Noninverting Amplifier

Layout Guidelines (continued)

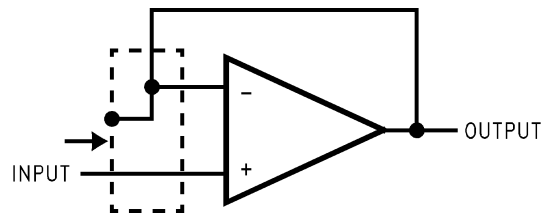
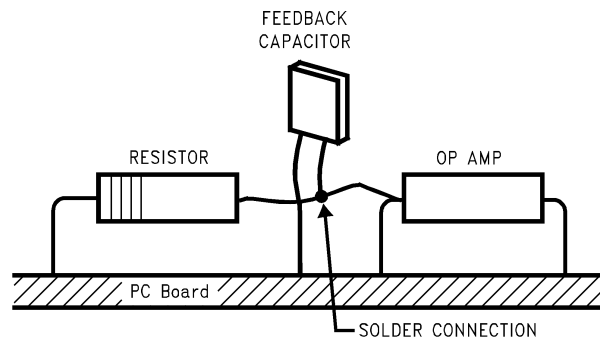

Figure 60. Typical Connections Of Guard Rings

The designer should be aware that when it is inappropriate to lay out a PCB for the sake of just a few circuits, there is another technique which is even better than a guard ring on a PCB: Do not insert the input pin of the amplifier into the board at all, but bend it up in the air and use only air as an insulator. Air is an excellent insulator. In this case you may have to forego some of the advantages of PCB construction, but the advantages are sometimes well worth the effort of using point-to-point up-in-the-air wiring. See [Figure 61](#).



(Input pins are lifted out of PCB and soldered directly to components. All other pins connected to PCB).

Figure 61. Air Wiring

Another potential source of leakage that might be overlooked is the device package. When the LFx5x is manufactured, the device is always handled with conductive finger cots. This is to assure that salts and skin oils do not cause leakage paths on the surface of the package. We recommend that these same precautions be adhered to, during all phases of inspection, test and assembly.

10.2 Layout Example

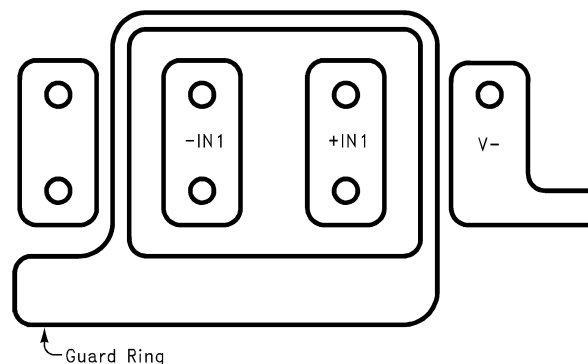

Figure 62. Examples Of Guard Ring In PCB Layout

11 Device and Documentation Support

11.1 Related Links

The table below lists quick access links. Categories include technical documents, support and community resources, tools and software, and quick access to sample or buy.

Table 2. Related Links

PARTS	PRODUCT FOLDER	SAMPLE & BUY	TECHNICAL DOCUMENTS	TOOLS & SOFTWARE	SUPPORT & COMMUNITY
LF156	Click here	Click here	Click here	Click here	Click here
LF256	Click here	Click here	Click here	Click here	Click here
LF356	Click here	Click here	Click here	Click here	Click here

11.2 Community Resources

The following links connect to TI community resources. Linked contents are provided "AS IS" by the respective contributors. They do not constitute TI specifications and do not necessarily reflect TI's views; see TI's [Terms of Use](#).

TI E2E™ Online Community *TI's Engineer-to-Engineer (E2E) Community*. Created to foster collaboration among engineers. At e2e.ti.com, you can ask questions, share knowledge, explore ideas and help solve problems with fellow engineers.

Design Support *TI's Design Support* Quickly find helpful E2E forums along with design support tools and contact information for technical support.

11.3 Trademarks

BI-FET, E2E are trademarks of Texas Instruments.
All other trademarks are the property of their respective owners.

11.4 Electrostatic Discharge Caution



These devices have limited built-in ESD protection. The leads should be shorted together or the device placed in conductive foam during storage or handling to prevent electrostatic damage to the MOS gates.

11.5 Glossary

[SLYZ022](#) — *TI Glossary*.

This glossary lists and explains terms, acronyms, and definitions.

12 Mechanical, Packaging, and Orderable Information

The following pages include mechanical, packaging, and orderable information. This information is the most current data available for the designated devices. This data is subject to change without notice and revision of this document. For browser-based versions of this data sheet, refer to the left-hand navigation.

PACKAGING INFORMATION

Orderable Device	Status (1)	Package Type	Package Drawing	Pins	Package Qty	Eco Plan (2)	Lead/Ball Finish (6)	MSL Peak Temp (3)	Op Temp (°C)	Device Marking (4/5)	Samples
LF156 MD8	ACTIVE	DIESALE	Y	0	204	Green (RoHS & no Sb/Br)	Call TI	Level-1-NA-UNLIM	-55 to 125		Samples
LF156H	ACTIVE	TO-99	LMC	8	500	TBD	Call TI	Call TI	-55 to 125	(LF156H ~ LF156H)	Samples
LF156H/NOPB	ACTIVE	TO-99	LMC	8	500	Green (RoHS & no Sb/Br)	Call TI	Level-1-NA-UNLIM	-55 to 125	(LF156H ~ LF156H)	Samples
LF256H	ACTIVE	TO-99	LMC	8	500	TBD	Call TI	Call TI	-25 to 85	(LF256H ~ LF256H)	Samples
LF256H/NOPB	ACTIVE	TO-99	LMC	8	500	Green (RoHS & no Sb/Br)	Call TI	Level-1-NA-UNLIM	-25 to 85	(LF256H ~ LF256H)	Samples
LF356M	NRND	SOIC	D	8	95	TBD	Call TI	Call TI	0 to 70	LF356 M	
LF356M/NOPB	ACTIVE	SOIC	D	8	95	Green (RoHS & no Sb/Br)	CU SN	Level-1-260C-UNLIM	0 to 70	LF356 M	Samples
LF356MX	NRND	SOIC	D	8	2500	TBD	Call TI	Call TI	0 to 70	LF356 M	
LF356MX/NOPB	ACTIVE	SOIC	D	8	2500	Green (RoHS & no Sb/Br)	CU SN	Level-1-260C-UNLIM	0 to 70	LF356 M	Samples
LF356N/NOPB	ACTIVE	PDIP	P	8	40	Green (RoHS & no Sb/Br)	CU SN	Level-1-NA-UNLIM	0 to 70	LF 356N	Samples

(1) The marketing status values are defined as follows:

ACTIVE: Product device recommended for new designs.

LIFEBUY: TI has announced that the device will be discontinued, and a lifetime-buy period is in effect.

NRND: Not recommended for new designs. Device is in production to support existing customers, but TI does not recommend using this part in a new design.

PREVIEW: Device has been announced but is not in production. Samples may or may not be available.

OBSOLETE: TI has discontinued the production of the device.

(2) **RoHS:** TI defines "RoHS" to mean semiconductor products that are compliant with the current EU RoHS requirements for all 10 RoHS substances, including the requirement that RoHS substance do not exceed 0.1% by weight in homogeneous materials. Where designed to be soldered at high temperatures, "RoHS" products are suitable for use in specified lead-free processes. TI may reference these types of products as "Pb-Free".

RoHS Exempt: TI defines "RoHS Exempt" to mean products that contain lead but are compliant with EU RoHS pursuant to a specific EU RoHS exemption.

Green: TI defines "Green" to mean the content of Chlorine (Cl) and Bromine (Br) based flame retardants meet JS709B low halogen requirements of <=1000ppm threshold. Antimony trioxide based flame retardants must also meet the <=1000ppm threshold requirement.

(3) MSL, Peak Temp. - The Moisture Sensitivity Level rating according to the JEDEC industry standard classifications, and peak solder temperature.

(4) There may be additional marking, which relates to the logo, the lot trace code information, or the environmental category on the device.

(5) Multiple Device Markings will be inside parentheses. Only one Device Marking contained in parentheses and separated by a "~" will appear on a device. If a line is indented then it is a continuation of the previous line and the two combined represent the entire Device Marking for that device.

(6) Lead/Ball Finish - Orderable Devices may have multiple material finish options. Finish options are separated by a vertical ruled line. Lead/Ball Finish values may wrap to two lines if the finish value exceeds the maximum column width.

Important Information and Disclaimer:The information provided on this page represents TI's knowledge and belief as of the date that it is provided. TI bases its knowledge and belief on information provided by third parties, and makes no representation or warranty as to the accuracy of such information. Efforts are underway to better integrate information from third parties. TI has taken and continues to take reasonable steps to provide representative and accurate information but may not have conducted destructive testing or chemical analysis on incoming materials and chemicals. TI and TI suppliers consider certain information to be proprietary, and thus CAS numbers and other limited information may not be available for release.

In no event shall TI's liability arising out of such information exceed the total purchase price of the TI part(s) at issue in this document sold by TI to Customer on an annual basis.

TAPE AND REEL INFORMATION



QUADRANT ASSIGNMENTS FOR PIN 1 ORIENTATION IN TAPE



*All dimensions are nominal

Device	Package Type	Package Drawing	Pins	SPQ	Reel Diameter (mm)	Reel Width W1 (mm)	A0 (mm)	B0 (mm)	K0 (mm)	P1 (mm)	W (mm)	Pin1 Quadrant
LF356MX	SOIC	D	8	2500	330.0	12.4	6.5	5.4	2.0	8.0	12.0	Q1
LF356MX/NOPB	SOIC	D	8	2500	330.0	12.4	6.5	5.4	2.0	8.0	12.0	Q1

TAPE AND REEL BOX DIMENSIONS



*All dimensions are nominal

Device	Package Type	Package Drawing	Pins	SPQ	Length (mm)	Width (mm)	Height (mm)
LF356MX	SOIC	D	8	2500	367.0	367.0	35.0
LF356MX/NOPB	SOIC	D	8	2500	367.0	367.0	35.0

D (R-PDSO-G8)

PLASTIC SMALL OUTLINE



- NOTES:
- A. All linear dimensions are in inches (millimeters).
 - B. This drawing is subject to change without notice.
 - \triangle Body length does not include mold flash, protrusions, or gate burrs. Mold flash, protrusions, or gate burrs shall not exceed 0.006 (0,15) each side.
 - \triangle Body width does not include interlead flash. Interlead flash shall not exceed 0.017 (0,43) each side.
 - E. Reference JEDEC MS-012 variation AA.

P (R-PDIP-T8)

PLASTIC DUAL-IN-LINE PACKAGE



- NOTES:
- A. All linear dimensions are in inches (millimeters).
 - B. This drawing is subject to change without notice.
 - C. Falls within JEDEC MS-001 variation BA.

LMC (O-MBCY-W8)

METAL CYLINDRICAL PACKAGE

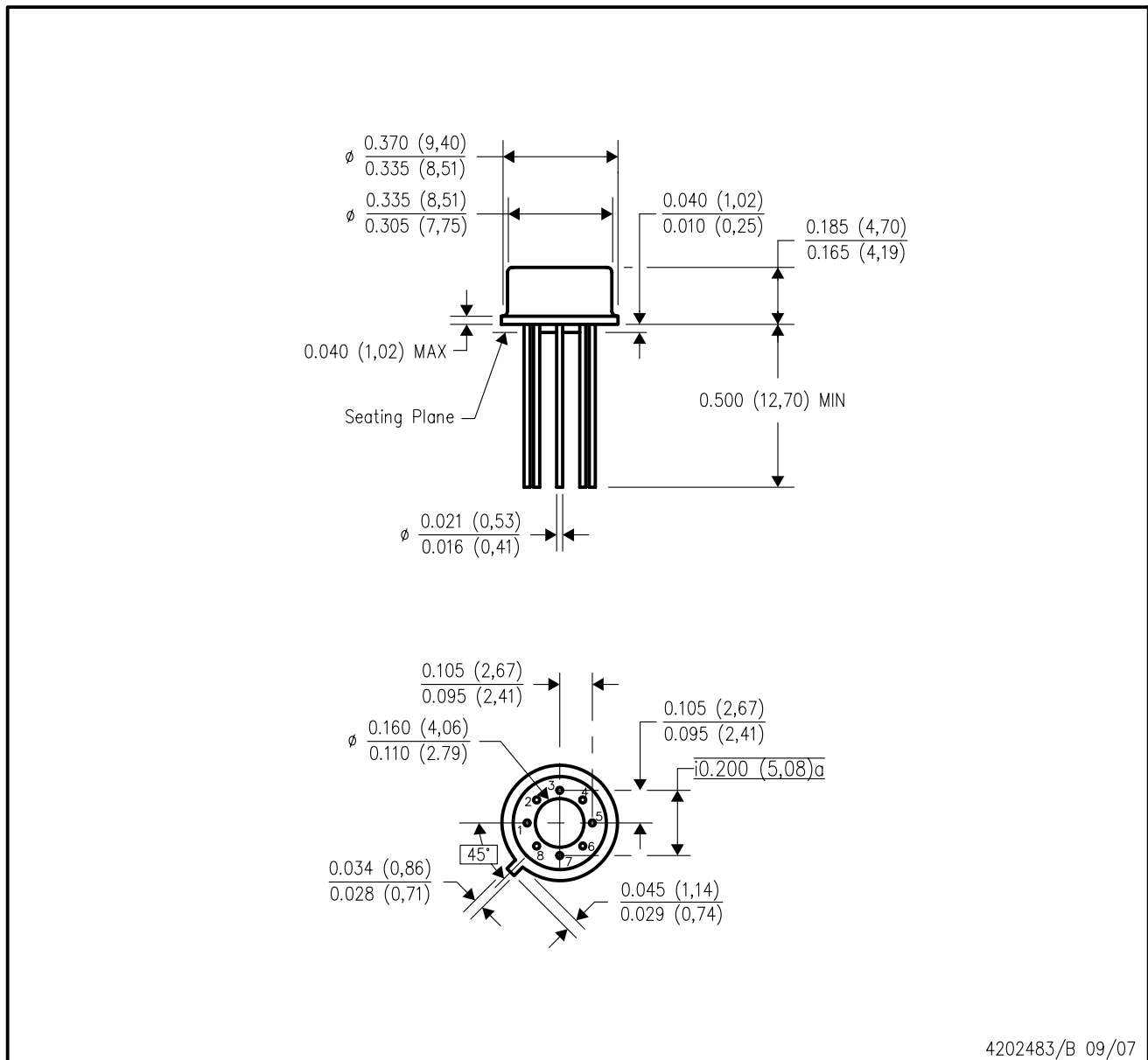

4202483/B 09/07

- NOTES:
- All linear dimensions are in inches (millimeters).
 - This drawing is subject to change without notice.
 - Leads in true position within 0.010 (0,25) R @ MMC at seating plane.
 - Pin numbers shown for reference only. Numbers may not be marked on package.
 - Falls within JEDEC MO-002/TO-99.

IMPORTANT NOTICE

Texas Instruments Incorporated (TI) reserves the right to make corrections, enhancements, improvements and other changes to its semiconductor products and services per JESD46, latest issue, and to discontinue any product or service per JESD48, latest issue. Buyers should obtain the latest relevant information before placing orders and should verify that such information is current and complete.

TI's published terms of sale for semiconductor products (<http://www.ti.com/sc/docs/stdterms.htm>) apply to the sale of packaged integrated circuit products that TI has qualified and released to market. Additional terms may apply to the use or sale of other types of TI products and services.

Reproduction of significant portions of TI information in TI data sheets is permissible only if reproduction is without alteration and is accompanied by all associated warranties, conditions, limitations, and notices. TI is not responsible or liable for such reproduced documentation. Information of third parties may be subject to additional restrictions. Resale of TI products or services with statements different from or beyond the parameters stated by TI for that product or service voids all express and any implied warranties for the associated TI product or service and is an unfair and deceptive business practice. TI is not responsible or liable for any such statements.

Buyers and others who are developing systems that incorporate TI products (collectively, "Designers") understand and agree that Designers remain responsible for using their independent analysis, evaluation and judgment in designing their applications and that Designers have full and exclusive responsibility to assure the safety of Designers' applications and compliance of their applications (and of all TI products used in or for Designers' applications) with all applicable regulations, laws and other applicable requirements. Designer represents that, with respect to their applications, Designer has all the necessary expertise to create and implement safeguards that (1) anticipate dangerous consequences of failures, (2) monitor failures and their consequences, and (3) lessen the likelihood of failures that might cause harm and take appropriate actions. Designer agrees that prior to using or distributing any applications that include TI products, Designer will thoroughly test such applications and the functionality of such TI products as used in such applications.

TI's provision of technical, application or other design advice, quality characterization, reliability data or other services or information, including, but not limited to, reference designs and materials relating to evaluation modules, (collectively, "TI Resources") are intended to assist designers who are developing applications that incorporate TI products; by downloading, accessing or using TI Resources in any way, Designer (individually or, if Designer is acting on behalf of a company, Designer's company) agrees to use any particular TI Resource solely for this purpose and subject to the terms of this Notice.

TI's provision of TI Resources does not expand or otherwise alter TI's applicable published warranties or warranty disclaimers for TI products, and no additional obligations or liabilities arise from TI providing such TI Resources. TI reserves the right to make corrections, enhancements, improvements and other changes to its TI Resources. TI has not conducted any testing other than that specifically described in the published documentation for a particular TI Resource.

Designer is authorized to use, copy and modify any individual TI Resource only in connection with the development of applications that include the TI product(s) identified in such TI Resource. NO OTHER LICENSE, EXPRESS OR IMPLIED, BY ESTOPPEL OR OTHERWISE TO ANY OTHER TI INTELLECTUAL PROPERTY RIGHT, AND NO LICENSE TO ANY TECHNOLOGY OR INTELLECTUAL PROPERTY RIGHT OF TI OR ANY THIRD PARTY IS GRANTED HEREIN, including but not limited to any patent right, copyright, mask work right, or other intellectual property right relating to any combination, machine, or process in which TI products or services are used. Information regarding or referencing third-party products or services does not constitute a license to use such products or services, or a warranty or endorsement thereof. Use of TI Resources may require a license from a third party under the patents or other intellectual property of the third party, or a license from TI under the patents or other intellectual property of TI.

TI RESOURCES ARE PROVIDED "AS IS" AND WITH ALL FAULTS. TI DISCLAIMS ALL OTHER WARRANTIES OR REPRESENTATIONS, EXPRESS OR IMPLIED, REGARDING RESOURCES OR USE THEREOF, INCLUDING BUT NOT LIMITED TO ACCURACY OR COMPLETENESS, TITLE, ANY EPIDEMIC FAILURE WARRANTY AND ANY IMPLIED WARRANTIES OF MERCHANTABILITY, FITNESS FOR A PARTICULAR PURPOSE, AND NON-INFRINGEMENT OF ANY THIRD PARTY INTELLECTUAL PROPERTY RIGHTS. TI SHALL NOT BE LIABLE FOR AND SHALL NOT DEFEND OR INDEMNIFY DESIGNER AGAINST ANY CLAIM, INCLUDING BUT NOT LIMITED TO ANY INFRINGEMENT CLAIM THAT RELATES TO OR IS BASED ON ANY COMBINATION OF PRODUCTS EVEN IF DESCRIBED IN TI RESOURCES OR OTHERWISE. IN NO EVENT SHALL TI BE LIABLE FOR ANY ACTUAL, DIRECT, SPECIAL, COLLATERAL, INDIRECT, PUNITIVE, INCIDENTAL, CONSEQUENTIAL OR EXEMPLARY DAMAGES IN CONNECTION WITH OR ARISING OUT OF TI RESOURCES OR USE THEREOF, AND REGARDLESS OF WHETHER TI HAS BEEN ADVISED OF THE POSSIBILITY OF SUCH DAMAGES.

Unless TI has explicitly designated an individual product as meeting the requirements of a particular industry standard (e.g., ISO/TS 16949 and ISO 26262), TI is not responsible for any failure to meet such industry standard requirements.

Where TI specifically promotes products as facilitating functional safety or as compliant with industry functional safety standards, such products are intended to help enable customers to design and create their own applications that meet applicable functional safety standards and requirements. Using products in an application does not by itself establish any safety features in the application. Designers must ensure compliance with safety-related requirements and standards applicable to their applications. Designer may not use any TI products in life-critical medical equipment unless authorized officers of the parties have executed a special contract specifically governing such use. Life-critical medical equipment is medical equipment where failure of such equipment would cause serious bodily injury or death (e.g., life support, pacemakers, defibrillators, heart pumps, neurostimulators, and implantables). Such equipment includes, without limitation, all medical devices identified by the U.S. Food and Drug Administration as Class III devices and equivalent classifications outside the U.S.

TI may expressly designate certain products as completing a particular qualification (e.g., Q100, Military Grade, or Enhanced Product). Designers agree that it has the necessary expertise to select the product with the appropriate qualification designation for their applications and that proper product selection is at Designers' own risk. Designers are solely responsible for compliance with all legal and regulatory requirements in connection with such selection.

Designer will fully indemnify TI and its representatives against any damages, costs, losses, and/or liabilities arising out of Designer's non-compliance with the terms and provisions of this Notice.

Mouser Electronics

Authorized Distributor

Click to View Pricing, Inventory, Delivery & Lifecycle Information:

[Texas Instruments:](#)

[LF356M](#) [LF356M/NOPB](#) [LF356MX](#) [LF356MX/NOPB](#) [LF356N](#) [LF356N/NOPB](#)