

6

5

4

3

2

1

APPROVED: \_\_\_\_\_

DATE: \_\_\_\_\_

TITLE: \_\_\_\_\_

Rev	AWO #	Description	Date	Appr
-		RELEASED	7/15/14	
A		UPDATE SHAPE	12/17/14	AV/RT
B		ADDED SPEC.	1/28/15	AV/RT
C		REVISED SPEC.	1/29/15	AV/RT
D		UPDATE SHAPE	7/3/15	AV/RT

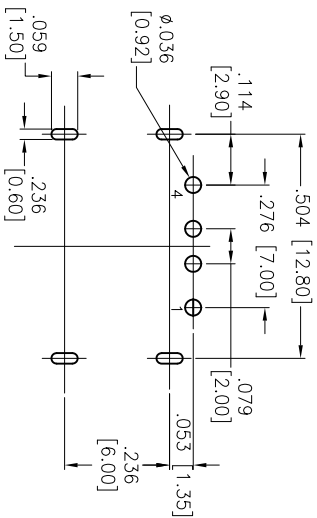
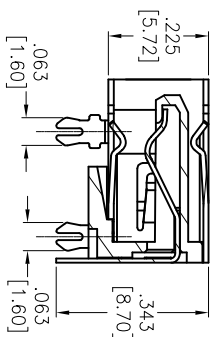
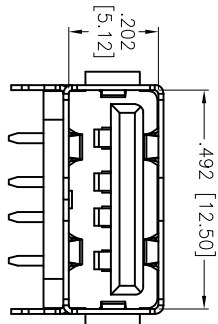

RECOMMENDED PCB LAYOUT

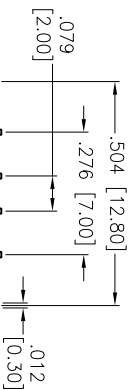
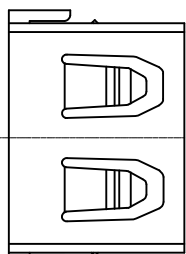
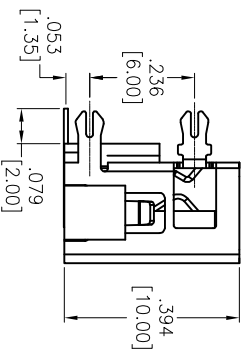
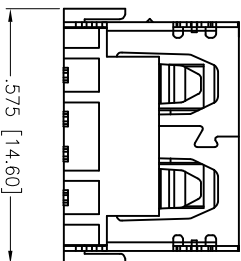

B

B

**SPECIFICATIONS:**

**Material:**  
 Insulator: Hi-Temp Thermoplastic, rated UL 94V-0  
 Insulator color: Black  
 Contacts: Copper Alloy  
 Shell: SPCC, nickel plated  
 Plating:  
 Gold flash over Nickel underplate on contact area,  
 Tin over Copper underplate on PCB tails.

**Electrical:**  
 Current rating: 5A for Vbus Pin, 1.25A for Vconn Pin.  
 Contact resistance: 30 mohms max.  
 Insulation resistance: 100 Mohms min @500 VDC  
 Dielectric withstanding voltage: 500 VAC for 1 minute

**Mechanical:**  
 Mating force: 5~20N  
 Unmated force: 8~20N After Test  
 Temperature Rating:  
 Operating temperature: -40°C to +85°C  
 Environmental:  
 Lead free, RoHS compliant.

# ADAM TECH

909 Rahway Avenue, Union, NJ 07083  
 Phone: 908-687-5000 Fax: 908-687-5710

TITLE: UNIVERSAL SERIAL BUS, TYPE A, PCB  
 RIGHT ANGLE, DOUBLE BOARD LOCKS, 2.0A

UNLESS OTHERWISE SPECIFIED ALL DIMENSIONS ARE INCHES [MM] TOLERANCES: EXCEPT AS NOTED	
INCHES	HOLDS
.X ± .10	ØX ± .10
.XX ± .020	ØXXX ± .015
.XXX ± .015	ØXXX ± .010
APPROVALS	DATE
DRAWN AY	7/15/14
CHECKED MW	7/15/14
APPROVED	

SIZE X	PART NO. USB-A-S-RA-DBL-CS6H-SPCC	REV. D
REF: S00097C	SCALE: NTS	SHEET 1 OF 1

6

5

4

3

2

1

A



# Mouser Electronics

Authorized Distributor

Click to View Pricing, Inventory, Delivery & Lifecycle Information:

[Adam Tech:](#)

[USB-A-S-RA-DBL-CS6H-SPCC](#)