

SPECIFICATION

- Part No. : **AP.10E.07.0039B**
- Product Name : AP.10E - 1 Stage 15dB 39mm 0.81 with IPEX
MHFI (U.FL compatible)
- Feature : World smallest GPS/GALILEO active patch
High performance
Ultra low power consumption
RoHS Compliant



1. Introduction

AP.10E active GPS/GALILEO patch antenna is the smallest GPS high performance antenna currently available in the world. Using extremely sensitive high dielectric constant powder formulation and tight process control the 10*10*4mm patch antenna is accurately tuned to have its frequency band right at 1575.42MHz for GPS systems. With an ultra low power consumption one stage LNA, this small active patch has the performance of an ordinary active patch, but at only a quarter of the size.

This product is suited to small form factor mobile devices such as GPS Smartphones, Personal Location, Medical devices, Telematic devices and Automotive navigation and tracking. Custom gain, connector and cable versions are available. The AP.10E consists of 2 functional blocks – the LNA and also the patch antenna.

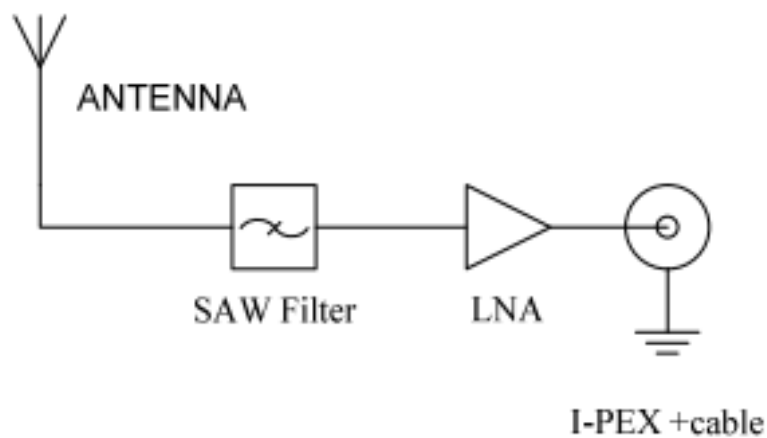

2. Specification

ELECTRICAL			
Frequency	1575.42 ± 1.023MHz		
Gain @ Zenith	-10dBic Typ. @ Zenith		
Polarization	RHCP		
Axial Ratio	4.0dB max. @Zenith		
Patch Dimension	10*10*4.0mm		
LNA			
Frequency	1575.42 ± 1.023MHz		
Outer Band Attenuation	F0=1575.42MHz		
	F0±30MHz	9dB min.	
	F0±50MHz	20dB min.	
	F0±100MHz	25dB min.	
Output Impedance	50Ω		
Output VSWR	2.0 Max		
Pout at 1dB Gain Compression point	Typ. -2dBm		
	Min. -6dBm		
LNA Gain, Power Consumption and Noise Figure			
Voltage	LNA Gain (Typ)	Power Consumption(mA) Typ	Noise Figure Typ
Min. 1.8V	14dB	3mA	2.5dB
Typ. 3.0V	15dB	3mA	2.5dB
Max. 5.5V	15dB	3mA	2.6dB
MECHANICAL			
Dimensions	10*10*4.0mm		
RF Cable	Coaxial Cable Ø0.81 ± 0.1mm, length 39 ± 2.0mm		
Connector	IPEX MHFI (U.FL)		
ANTENNA WITH LNA			
Frequency	1575.42 ± 1.023MHz		
Gain	At 3V: 5 ± 4dBi@90°		
Output Impedance	50Ω		
Polarization	RHCP		
Output VSWR	Max 2.0		
Operation Temperature	-40°C to + 85°C		
Storage Temperature	-40°C to + 85°C		
Relative Humidity	40% to 95%		
Input Voltage	Min:1.8V Typ. 3.0V Max:5.5V		
Antenna	10*10*5.9mm		

3. LNA Gain and Out Band Rejection @3.0V

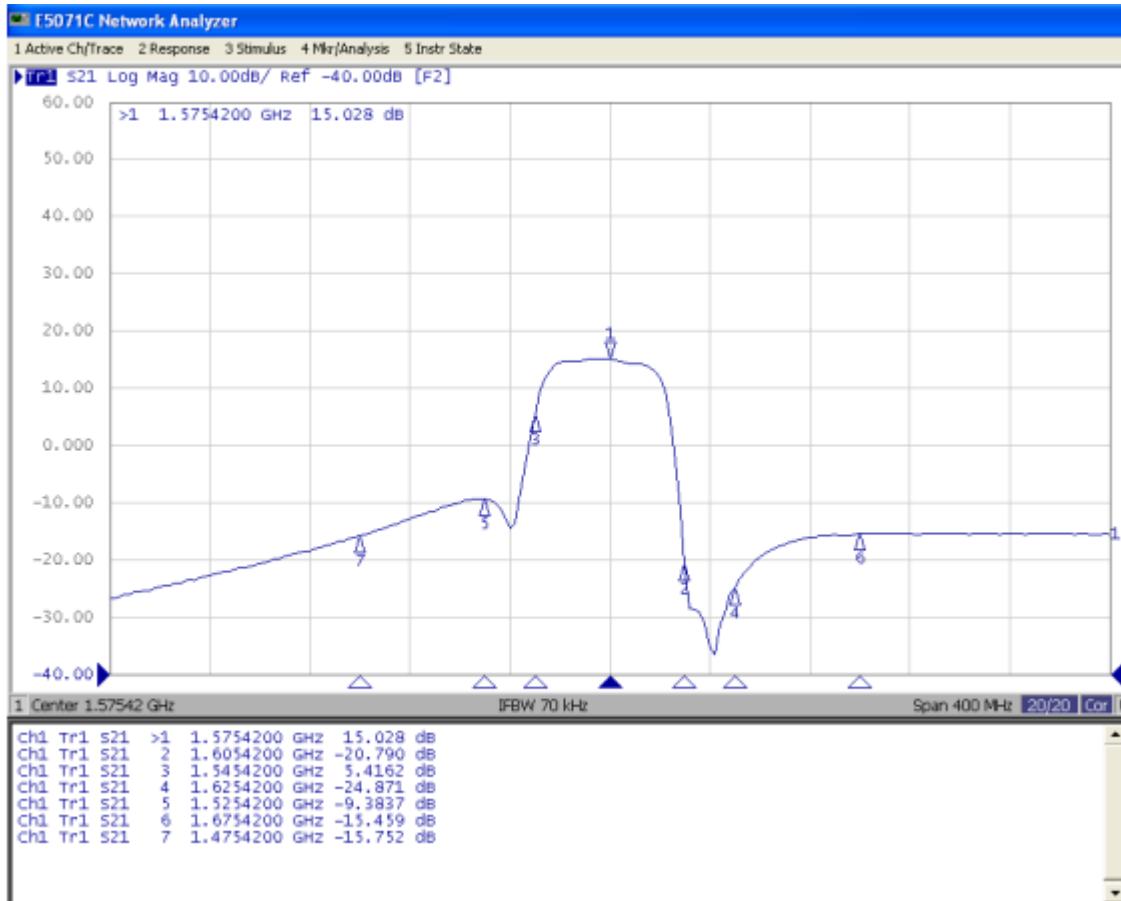

4. LNA Noise Figure @3.0V

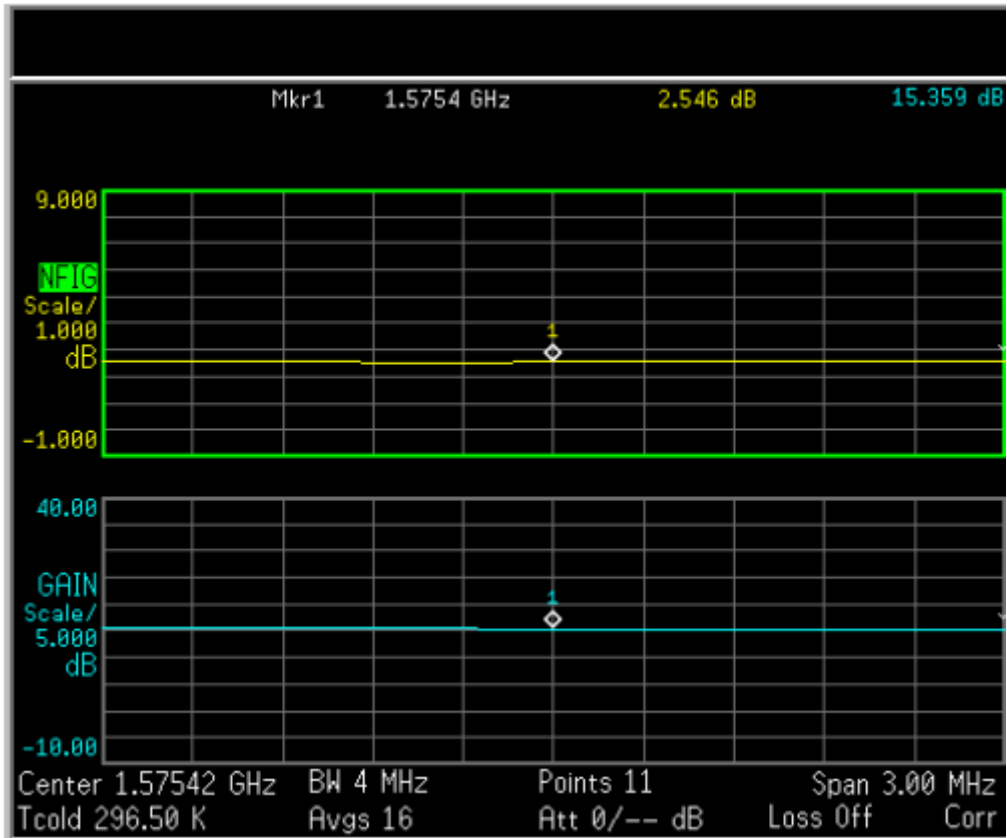

5. Radiation Pattern

XZ Plane Radiation

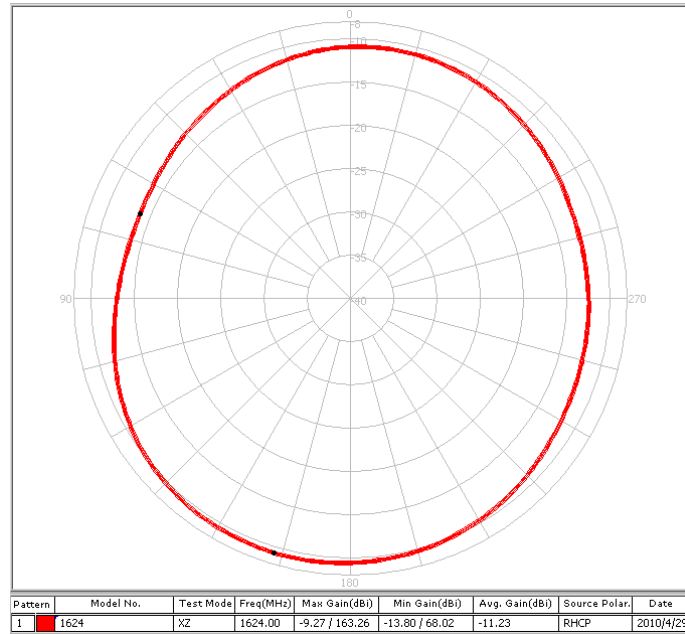

YZ Plane Radiation

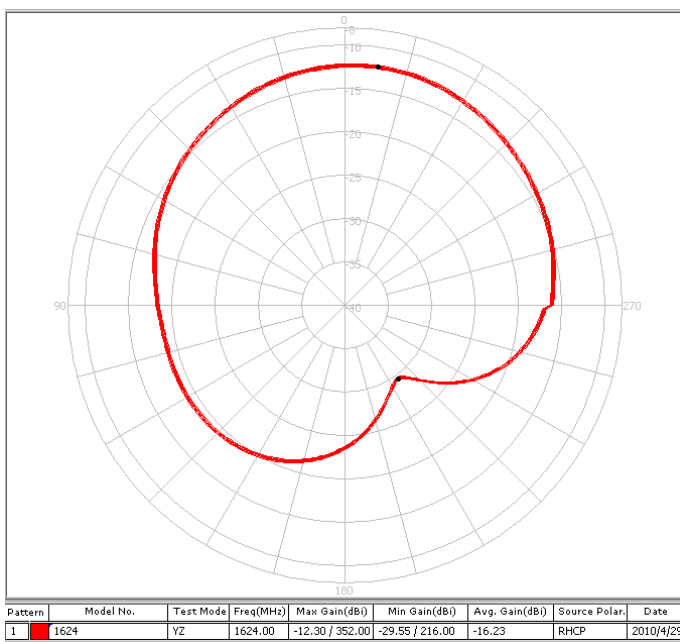

XY Plane Radiation

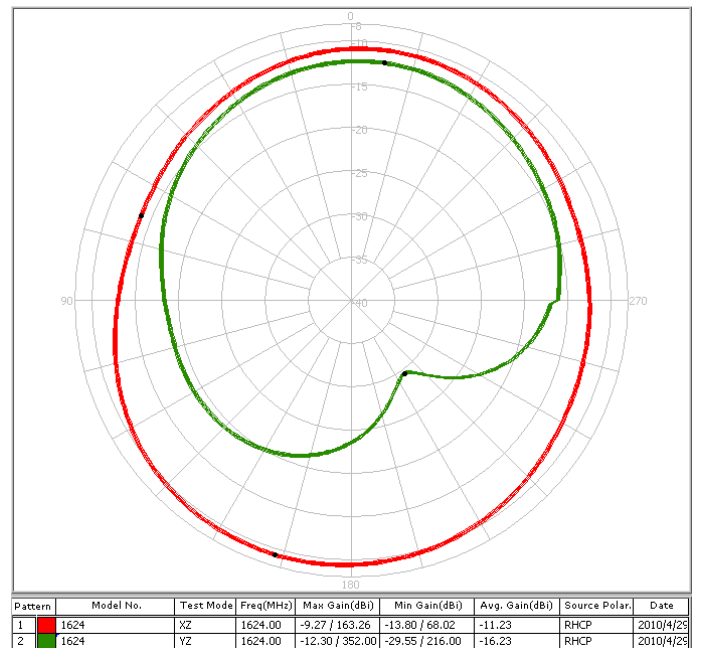

6. Antenna Drawing

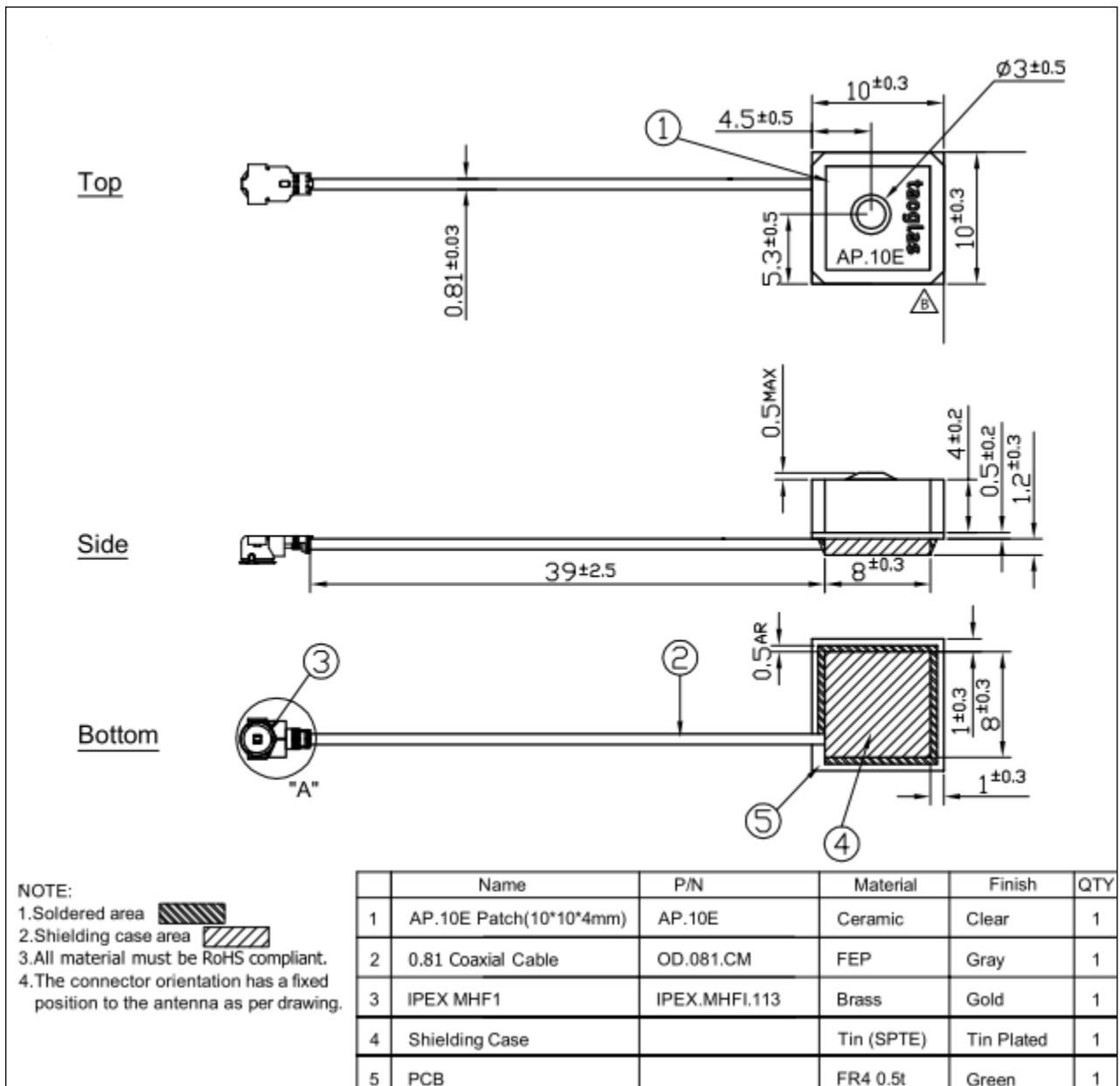
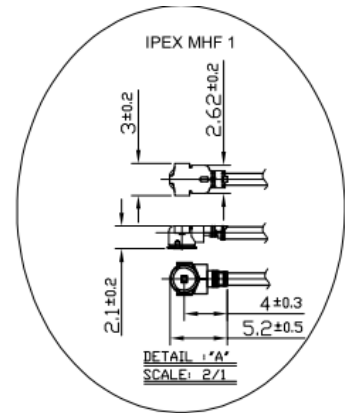

7. Plugs Usage Precautions

7.1. Mating / Unmating

- (1) To disconnect connectors, insert the end portion of I-PEX under the connector flanges and pull off vertically, in the direction of the connector mating axis.
- (2) To mate the connectors, the mating axes of both connectors must be aligned and the connectors can be mated. The "click" will confirm fully mated connection. Do not attempt to insert on an extreme angle.

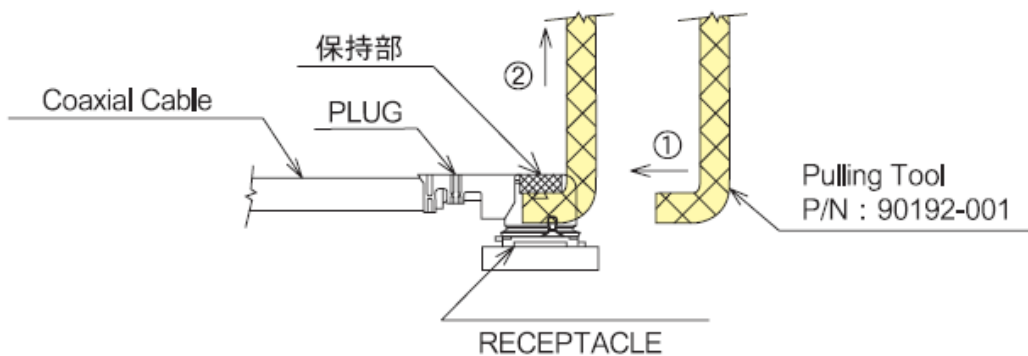

7.2. Pull forces on the cable after connectors are mated

After the connectors are mated, do not apply a load to the cable in excess of the values indicated in the diagram below.

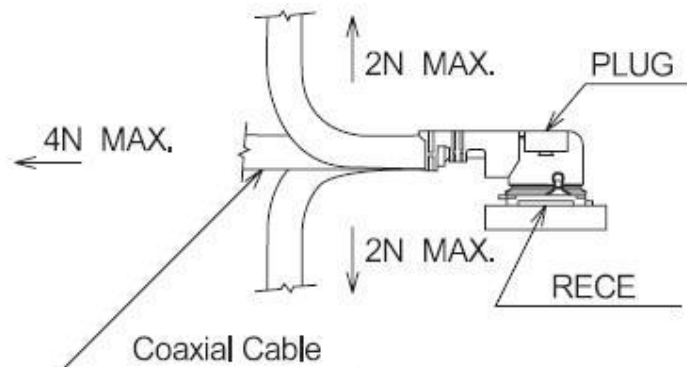

8. Packaging

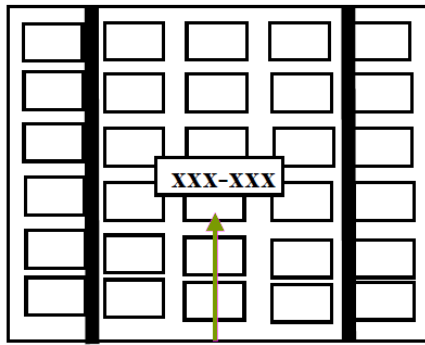

- *Packaged in Tray with Foam
- *One Tray = 60 pieces
- *6 Trays per Section = 360 pcs

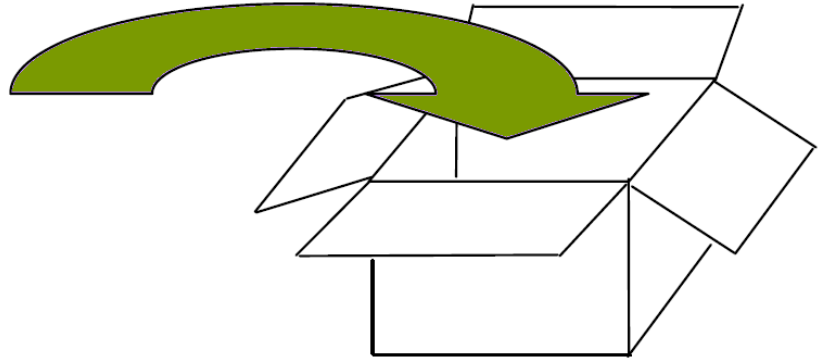

- *Each Carton contains 3 Sections
- *1080 pieces per Carton

Taoglas makes no warranties based on the accuracy or completeness of the contents of this document and reserves the right to make changes to specifications and product descriptions at any time without notice. Taoglas reserves all rights to this document and the information contained herein.

Reproduction, use or disclosure to third parties without express permission is strictly prohibited.

Copyright © Taoglas Ltd.

Mouser Electronics

Authorized Distributor

Click to View Pricing, Inventory, Delivery & Lifecycle Information:

[Taoglas:](#)

[AP.10E.07.0039B](#)