

Notice for TAIYO YUDEN Products

Please read this notice before using the TAIYO YUDEN products.

⚠ REMINDERS

Product Information in this Catalog

Product information in this catalog is as of March 2023. All of the contents specified herein and production status of the products listed in this catalog are subject to change without notice due to technical improvement of our products, etc. Therefore, please check for the latest information carefully before practical application or use of our products.

Please note that TAIYO YUDEN shall not be in any way responsible for any damages and defects in products or equipment incorporating our products, which are caused under the conditions other than those specified in this catalog or individual product specification sheets.

Approval of Product Specifications

Please contact TAIYO YUDEN for further details of product specifications as the individual product specification sheets are available. When using our products, please be sure to approve our product specifications or make a written agreement on the product specification with TAIYO YUDEN in advance.

Pre-Evaluation in the Actual Equipment and Conditions

Please conduct validation and verification of our products in actual conditions of mounting and operating environment before using our products.

Limited Application

1. Equipment Intended for Use

The products listed in this catalog are intended for general-purpose and standard use in general electronic equipment for consumer (e.g., AV equipment, OA equipment, home electric appliances, office equipment, information and communication equipment including, without limitation, mobile phone, and PC) and other equipment specified in this catalog or the individual product specification sheets, or the equipment approved separately by TAIYO YUDEN.

TAIYO YUDEN has the product series intended for use in the following equipment. Therefore, when using our products for these equipment, please check available applications specified in this catalog or the individual product specification sheets and use the corresponding products.

Application	Product Series		Quality Grade ^{*3}
	Equipment ^{*1}	Category (Part Number Code ^{*2})	
Automotive	Automotive Electronic Equipment (POWERTRAIN, SAFETY)	A	1
	Automotive Electronic Equipment (BODY & CHASSIS, INFOTAINMENT)	C	2
Industrial	Telecommunications Infrastructure and Industrial Equipment	B	2
Medical	Medical Devices classified as GHTF Class C (Japan Class III)	M	2
	Medical Devices classified as GHTF Classes A or B (Japan Classes I or II)	L	3
Consumer	General Electronic Equipment	S	3
	Only for Mobile Devices ^{*4}	E	4

*Notes: 1. Based on the general specifications required for electronic components for such equipment, which are recognized by TAIYO YUDEN, the use of each product series for the equipment is recommended. Please be sure to contact TAIYO YUDEN before using our products for equipment other than those covered by the product series.

2. On each of our part number, the 2nd code from the left is a code indicating the "Category" as shown in the above table. For details, please check the explanatory materials regarding the part numbering system of each of our products.

3. Each product series is assigned a "Quality Grade" from 1 to 4 in order of higher quality. Please do not incorporate a product into any equipment with a higher Quality Grade than the Quality Grade of such product without the prior written consent of TAIYO YUDEN.

4. The applications covered by this product series are limited to mobile devices (smartphone, tablet PC, smartwatch, handheld game console, etc.) among general electronic equipment for consumer. The design, specifications and operating environment, etc. differ from those of the product series for "General Electronic Equipment" (Category: S), so please check the individual product specification sheets for details. The product series for "General Electronic Equipment" (Category: S) can also be used for mobile devices.

▶ This catalog contains the typical specification only due to the limitation of space. When you consider the purchase of our products, please check our product specification sheets. For details of each product (characteristics graph, reliability information, precautions for use, and so on), see our website (<http://www.ty-top.com/>).

2. Equipment Requiring Inquiry

Please be sure to contact TAIYO YUDEN for further information before using the products listed in this catalog for the following equipment (excluding intended equipment as specified in this catalog or the individual product specification sheets) which may cause loss of human life, bodily injury, serious property damage and/or serious public impact due to a failure or defect of the products and/or malfunction attributed thereto.

- (1) Transportation equipment (automotive powertrain control system, train control system, and ship control system, etc.)
- (2) Traffic signal equipment
- (3) Disaster prevention equipment, crime prevention equipment
- (4) Medical devices classified as GHTF Class C (Japan Class III)
- (5) Highly public information network equipment, data-processing equipment (telephone exchange, and base station, etc.)
- (6) Any other equipment requiring high levels of quality and/or reliability equal to the equipment listed above

3. Equipment Prohibited for Use

Please do not incorporate our products into the following equipment requiring extremely high levels of safety and/or reliability.

- (1) Aerospace equipment (artificial satellite, rocket, etc.)
- (2) Aviation equipment *1
- (3) Medical devices classified as GHTF Class D (Japan Class IV), implantable medical devices *2
- (4) Power generation control equipment (nuclear power, hydroelectric power, thermal power plant control system, etc.)
- (5) Undersea equipment (submarine repeating equipment, etc.)
- (6) Military equipment
- (7) Any other equipment requiring extremely high levels of safety and/or reliability equal to the equipment listed above

*Notes: 1. There is a possibility that our products can be used only for aviation equipment that does not directly affect the safe operation of aircraft (e.g., in-flight entertainment, cabin light, electric seat, cooking equipment) if such use meets requirements specified separately by TAIYO YUDEN. Please be sure to contact TAIYO YUDEN for further information before using our products for such aviation equipment.

2. Implantable medical devices contain not only internal unit which is implanted in a body, but also external unit which is connected to the internal unit.

4. Limitation of Liability

Please note that unless you obtain prior written consent of TAIYO YUDEN, TAIYO YUDEN shall not be in any way responsible for any damages incurred by you or third parties arising from use of the products listed in this catalog for any equipment that is not intended for use by TAIYO YUDEN, or any equipment requiring inquiry to TAIYO YUDEN or prohibited for use by TAIYO YUDEN as described above.

■ Safety Design

When using our products for high safety and/or reliability-required equipment or circuits, please fully perform safety and/or reliability evaluation. In addition, please install (i) systems equipped with a protection circuit and a protection device and/or (ii) systems equipped with a redundant circuit or other system to prevent an unsafe status in the event of a single fault for a failsafe design to ensure safety.

■ Intellectual Property Rights

Information contained in this catalog is intended to convey examples of typical performances and/or applications of our products and is not intended to make any warranty with respect to the intellectual property rights or any other related rights of TAIYO YUDEN or any third parties nor grant any license under such rights.

■ Limited Warranty

Please note that the scope of warranty for our products is limited to the delivered our products themselves conforming to the product specifications specified in the individual product specification sheets, and TAIYO YUDEN shall not be in any way responsible for any damages resulting from a failure or defect in our products. Notwithstanding the foregoing, if there is a written agreement (e.g., supply and purchase agreement, quality assurance agreement) signed by TAIYO YUDEN and your company, TAIYO YUDEN will warrant our products in accordance with such agreement, provided, however, that our products shall be used for general-purpose and standard use in the equipment specified in this catalog or the individual product specification sheets.

■ TAIYO YUDEN's Official Sales Channel

The contents of this catalog are applicable to our products which are purchased from our sales offices or authorized distributors (hereinafter "TAIYO YUDEN's official sales channel"). Please note that the contents of this catalog are not applicable to our products purchased from any seller other than TAIYO YUDEN's official sales channel.

■ Caution for Export

Some of our products listed in this catalog may require specific procedures for export according to "U.S. Export Administration Regulations", "Foreign Exchange and Foreign Trade Control Law" of Japan, and other applicable regulations. Should you have any questions on this matter, please contact our sales staff.

▶ This catalog contains the typical specification only due to the limitation of space. When you consider the purchase of our products, please check our product specification sheets. For details of each product (characteristics graph, reliability information, precautions for use, and so on), see our website (<http://www.ty-top.com/>).

Medical Application Guide

According to the medical devices classified as GHTF Classes A to C (Japan Classes I to III), we have the corresponding product series (the 2nd code from the left side of the part number is “M” or “L”) intended for use in the medical devices. Therefore, when using our products for the medical devices, please be sure to check the classification based on the GHTF Rules and use the corresponding product series.

On the other hand, we don't have the product series intended for use in (i) all medical devices classified as GHTF Class D (Japan Class IV) and (ii) implantable medical devices (bone-anchored hearing aid, artificial retina system, and external unit which is connected to internal unit which is implanted in a body, etc.). Therefore, please do not incorporate our products into these medical devices. Should you have any questions on this matter, please contact us.

Risk Level		Low High			
Japan	Classification according to the PMD Act of Japan (based on the GHTF Rules)	Class I General Medical Devices (GHTF Class A)	Class II Controlled Medical Devices (GHTF Class B)	Class III Specially-controlled Medical Devices (GHTF Class C)	Class IV Specially-controlled Medical Devices (GHTF Class D)
		Medical devices with extremely low risk to the human body in case of problems [Ex.] • In Vitro Diagnostic Devices • Nebulizer • Blood Gas Analyzer • Plethysmographs • Breathing Sensor • AC-powered Operating Table • Surgical Light • Cholesterol Analysis Device • Blood Type Analysis Device, etc.	Medical devices with relatively low risk to the human body in case of problems [Ex.] • Electronic Thermometer • Electronic Blood Pressure Gauge • Electronic Endoscope • Hearing Aid • Electrocardiograph • MRI • Ultrasonic Diagnostic System • Diagnostic Imaging Equipment • X-ray Diagnostic Equipment • Central Monitor • Pulse Oximeter, etc.	Medical devices with relatively high risk to the human body in case of problems [Ex.] • Dialysis Machine • Radiation Therapy Equipment • Infusion Pump • Respirator • Glucose Monitoring System • AED (Automated External Defibrillator) • Skin Laser Scanner • Electric Surgical Unit • Insulin Pump, etc.	Medical devices highly invasive to patients and with life-threatening risk in case of problems [Ex.] • Cardiac Pacemaker • Video Flexible Angioscope • Implantable Infusion Pump • Cardiac Electrosurgical Unit • Inspection Device with Cardiac Catheter • Defibrillator, etc.
U.S.A.	FDA Classification	Class I General Controls	Class II General Controls and Special Controls	Class III General Controls and Premarket Approval	
		Medical devices without the possibility of causing serious injury or harm to the patient or user even if there is a defect or malfunction in such medical devices	Medical devices with the possibility of causing injury or harm to the patient or user if there is a defect or malfunction in such medical devices	Medical devices with the possibility of causing serious injury, disability or death to the patient or user if a defect or malfunction occurs in such medical devices	
Corresponding TAIYO YUDEN Product Series	Product Series for Medical Devices classified as GHTF Classes A or B (Japan Classes I or II) (The 2nd Code from the Left Side of the Part Number: “L”)		Product Series for Medical Devices classified as GHTF Class C (Japan Class III) (The 2nd Code from the Left Side of the Part Number: “M”) (See the Note below.)		N / A

* Note : It is prohibited that our products are used in some medical devices such as implantable medical devices even if such medical devices are classified as GHTF Class C (Japan Class III).

► This catalog contains the typical specification only due to the limitation of space. When you consider the purchase of our products, please check our product specification sheets. For details of each product (characteristics graph, reliability information, precautions for use, and so on), see our website (<http://www.ty-top.com/>).

Wire-wound Ferrite Power Inductors LMXH series for Medical Devices classified as GHTF Class C (Japan Class III)

Code in front of Series have been extracted from Part number, which describes the segment of products, such as kinds and characteristics.

REFLOW

PART NUMBER

*Operating Temp. : -40~125°C (Including self-generated heat)

L	M	X	H	F	6	0	6	0	Y	E	L	1	0	0	M	M	R
①	②	③	④	⑤	⑥	⑦	⑧										

① Series

Code (1)(2)(3)(4)	
LMXH	Wire-wound Ferrite Power Inductor for Medical Devices classified as GHTF Class C (Japan Class III)

(1) Product Group

Code	
L	Inductors

(2) Category

Code	Recommended equipment	Quality Grade
M	Medical Devices classified as GHTF Class C (Japan Class III)	2

② Features

Code	Feature
F	Bottom electrode (Ag x solder) for fillet

③ Dimensions (L x W)

Code	Dimensions (L x W) [mm]
3030	3.0 x 3.0
4040	4.0 x 4.0
5050	5.0 x 5.0
6060	6.0 x 6.0

④ Dimensions (H)

Code	Dimensions (H) [mm]
QK	1.5
WK	2.0
WB	2.2
XK	3.0
XA	3.1
YE	4.5

(3) Type

Code	
X	Ferrite Wire-wound (Drum type)

(4) Features, Characteristics

Code	
H	Hybrid power choke

⑤ Packaging

Code	Packaging
T	Taping
L	Taping

⑥ Nominal inductance

Code (example)	Nominal inductance [μH]
2R2	2.2
100	10
101	100

※R=Decimal point

⑦ Inductance tolerance

Code	Inductance tolerance
M	±20%
N	±30%

⑧ Internal code

■ STANDARD EXTERNAL DIMENSIONS / STANDARD QUANTITY

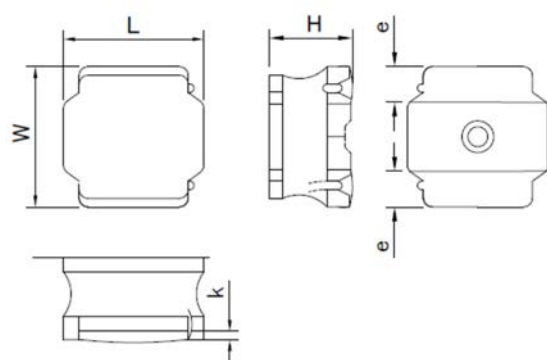

Recommended Land Patterns

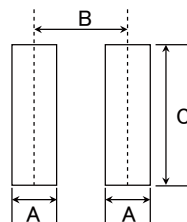

Type	A	B	C
3030	1.3	2.3	2.7
4040	1.5	3.3	3.5
5050	1.9	4.2	3.8
6060	2.4	5.0	4.8

Unit: mm

Type	L	W	H	e	k(ref)	Standard quantity [pcs] Taping
3030QK	3.0±0.2 (0.118±0.008)	3.0±0.2 (0.118±0.008)	1.5 max (0.059 max)	0.8±0.3 (0.031±0.012)	0.1 min (0.004 min)	2000
4040WK	4.0±0.2 (0.158±0.008)	4.0±0.2 (0.158±0.008)	2.0 max (0.079 max)	1.0±0.3 (0.039±0.012)	0.1 min (0.004 min)	700
5050WB	5.0±0.2 (0.197±0.008)	5.0±0.2 (0.197±0.008)	2.2 max (0.088 max)	1.3±0.3 (0.051±0.012)	0.2 min (0.008 min)	800
5050XA	5.0±0.2 (0.197±0.008)	5.0±0.2 (0.197±0.008)	3.1 max (0.122 max)	1.3±0.3 (0.051±0.012)	0.2 min (0.008 min)	500
6060XK	6.0±0.2 (0.236±0.008)	6.0±0.2 (0.236±0.008)	3.0 max (0.118 max)	1.65±0.3 (0.053±0.012)	0.3 min (0.012 min)	2000

Unit: mm(inch)

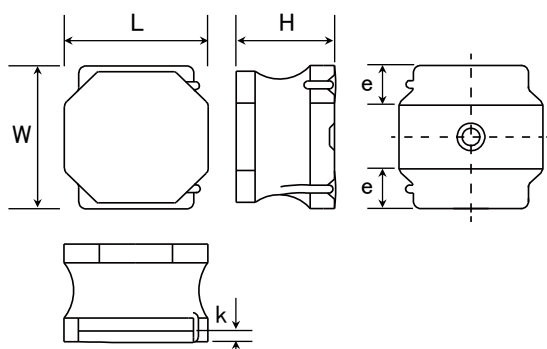

Recommended Land Patterns

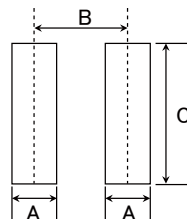

Type	A	B	C
6060	2.4	5.0	4.8

Unit: mm

Type	L	W	H	e	k(ref)	Standard quantity [pcs] Taping
6060YE	6.0±0.2 (0.236±0.008)	6.0±0.2 (0.236±0.008)	4.5 max (0.177 max)	1.65±0.3 (0.053±0.012)	0.3 min (0.012 min)	1500

Unit: mm(inch)

► This catalog contains the typical specification only due to the limitation of space. When you consider the purchase of our products, please check our specification. For details of each product (characteristics graph, reliability information, precautions for use, and so on), see our Web site (<http://www.ty-top.com/>).

■ PART NUMBER

• All the Wire-wound Ferrite Power Inductors of the catalog lineup are RoHS compliant.

Notes)
 • The exchange of individual specifications is necessary depending on your application and/or circuit condition. Please contact TAIYO YUDEN's official sales channel.
 • The products are for Medical Devices classified as GHTF Class C (Japan Class III).
 Please consult with TAIYO YUDEN's official sales channel for the details of the product specifications, etc., and please review and approve the product specifications before ordering.

● 3030QK type

New part number	Old part number (for reference)	Nominal inductance [μH]	Inductance tolerance	DC Resistance [mΩ] Max (Typ)	Rated current ※) [A]			Measuring frequency [MHz]
					Saturation current Idc1 Max (Typ)	Temperature rise current① Idc2 Max (Typ)	Temperature rise current② Idc2 Max (Typ)	
LMXHF3030QKTR47MNR	NRM3015T R47MNR8	0.47	±20%	23 (18)	3.10 (4.50)	2.20 (2.60)	4.00 (4.55)	0.1
LMXHF3030QKT1R0MNR	NRM3015T 1R0MNR8	1	±20%	33 (28)	2.30 (3.20)	1.70 (2.10)	3.20 (3.60)	0.1
LMXHF3030QKT1R5MNR	NRM3015T 1R5MNR8	1.5	±20%	46 (38)	1.80 (2.25)	1.60 (2.00)	2.60 (2.95)	0.1
LMXHF3030QKT2R2MNR	NRM3015T 2R2MNR8	2.2	±20%	72 (60)	1.50 (1.90)	1.40 (1.80)	2.30 (2.60)	0.1
LMXHF3030QKT3R3MNR	NRM3015T 3R3MNR8	3.3	±20%	96 (80)	1.20 (1.63)	1.20 (1.60)	1.90 (2.20)	0.1
LMXHF3030QKT4R7MNR	NRM3015T 4R7MNR8	4.7	±20%	120 (100)	1.00 (1.40)	1.00 (1.40)	1.70 (1.90)	0.1
LMXHF3030QKT6R8MNR	NRM3015T 6R8MNR8	6.8	±20%	168 (140)	0.90 (1.15)	0.85 (1.20)	1.40 (1.60)	0.1
LMXHF3030QKT100MNR	NRM3015T 100MNR8	10	±20%	228 (190)	0.76 (0.91)	0.75 (1.00)	1.24 (1.40)	0.1
LMXHF3030QKT220MNR	NRM3015T 220MNR8	22	±20%	504 (420)	0.51 (0.66)	0.53 (0.70)	0.85 (0.95)	0.1
LMXHF3030QKT470MNR	NRM3015T 470MNR8	47	±20%	980 (820)	0.29 (0.39)	0.38 (0.50)	0.60 (0.65)	0.1
LMXHF3030QKT101MNR	NRM3015T 101MNR8	100	±20%	2028 (1690)	0.21 (0.27)	0.24 (0.33)	0.40 (0.45)	0.1

● 4040WK type

New part number	Old part number (for reference)	Nominal inductance [μH]	Inductance tolerance	DC Resistance [mΩ] Max (Typ)	Rated current ※) [A]			Measuring frequency [MHz]
					Saturation current Idc1 Max (Typ)	Temperature rise current① Idc2 Max (Typ)	Temperature rise current② Idc2 Max (Typ)	
LMXHF4040WKT1R0MNR	NRM4020T 1R0MNR8	1	±20%	31 (26)	4.60 (5.30)	2.43 (3.36)	3.66 (4.15)	0.1
LMXHF4040WKT2R2MNR	NRM4020T 2R2MNR8	2.2	±20%	52 (43)	3.00 (3.40)	1.91 (2.65)	3.00 (3.37)	0.1
LMXHF4040WKT4R7MNR	NRM4020T 4R7MNR8	4.7	±20%	84 (70)	2.00 (2.40)	1.50 (2.08)	2.27 (2.60)	0.1
LMXHF4040WKT100MNR	NRM4020T 100MNR8	10	±20%	156 (130)	1.50 (1.70)	1.05 (1.45)	1.63 (1.85)	0.1
LMXHF4040WKT220MNR	NRM4020T 220MNR8	22	±20%	360 (300)	1.00 (1.20)	0.71 (0.99)	1.09 (1.25)	0.1
LMXHF4040WKT470MNR	NRM4020T 470MNR8	47	±20%	660 (550)	0.70 (0.80)	0.53 (0.73)	0.80 (0.85)	0.1
LMXHF4040WKT101MNR	NRM4020T 101MNR8	100	±20%	1512 (1260)	0.46 (0.57)	0.34 (0.48)	0.53 (0.56)	0.1
LMXHF4040WKT221MNR	NRM4020T 221MNR8	220	±20%	3360 (2800)	0.33 (0.37)	0.23 (0.32)	0.36 (0.375)	0.1

● 5050WB type

New part number	Old part number (for reference)	Nominal inductance [μH]	Inductance tolerance	DC Resistance [mΩ] Max (Typ)	Rated current ※) [A]			Measuring frequency [MHz]
					Saturation current Idc1 Max (Typ)	Temperature rise current① Idc2 Max (Typ)	Temperature rise current② Idc2 Max (Typ)	
LMXHF5050WBT1R0MNR	NRM5020T 1R0MNR8	1	±30%	24 (20)	5.00 (5.50)	2.60 (3.60)	4.40 (4.90)	0.1
LMXHF5050WBT1R5MNR	NRM5020T 1R5MNR8	1.5	±30%	32 (27)	4.00 (4.50)	2.40 (3.30)	4.00 (4.50)	0.1
LMXHF5050WBT2R2MNR	NRM5020T 2R2MNR8	2.2	±30%	36 (30)	3.20 (3.60)	2.10 (2.90)	3.50 (4.00)	0.1
LMXHF5050WBT3R3MNR	NRM5020T 3R3MNR8	3.3	±30%	49 (42)	2.50 (2.90)	1.90 (2.60)	3.10 (3.60)	0.1
LMXHF5050WBT4R7MNR	NRM5020T 4R7MNR8	4.7	±20%	69.6 (58)	2.10 (2.40)	1.50 (2.10)	2.60 (2.90)	0.1
LMXHF5050WBT100MNR	NRM5020T 100MNR8	10	±20%	127.2 (106)	1.50 (1.70)	1.10 (1.50)	1.80 (2.00)	0.1
LMXHF5050WBT220MNR	NRM5020T 220MNR8	22	±20%	280 (230)	1.10 (1.20)	0.80 (1.10)	1.30 (1.50)	0.1
LMXHF5050WBT470MNR	NRM5020T 470MNR8	47	±20%	520 (435)	0.73 (0.81)	0.58 (0.80)	0.97 (1.00)	0.1
LMXHF5050WBT101MNR	NRM5020T 101MNR8	100	±20%	1020 (850)	0.50 (0.56)	0.42 (0.58)	0.69 (0.78)	0.1

● 5050XA type

New part number	Old part number (for reference)	Nominal inductance [μH]	Inductance tolerance	DC Resistance [mΩ] Max (Typ)	Rated current ※) [A]			Measuring frequency [MHz]
					Saturation current Idc1 Max (Typ)	Temperature rise current① Idc2 Max (Typ)	Temperature rise current② Idc2 Max (Typ)	
LMXHF5050XATR47NMR	NRM5030T R47NMRP8	0.47	±30%	13 (10)	11.00 (12.00)	4.10 (5.50)	6.80 (7.70)	0.1
LMXHF5050XAT1R0MNR	NRM5030T 1R0MNR8	1	±30%	18.5 (14)	7.50 (8.00)	3.10 (4.30)	5.10 (5.80)	0.1
LMXHF5050XAT1R5MNR	NRM5030T 1R5MNR8	1.5	±30%	21.6 (18)	6.30 (6.80)	2.80 (3.70)	4.50 (5.10)	0.1
LMXHF5050XAT2R2MNR	NRM5030T 2R2MNR8	2.2	±30%	29 (24)	5.10 (5.60)	2.50 (3.40)	4.00 (4.60)	0.1
LMXHF5050XAT3R3MNR	NRM5030T 3R3MNR8	3.3	±30%	37 (32)	4.30 (4.80)	2.10 (2.90)	3.50 (3.90)	0.1
LMXHF5050XAT4R7MNR	NRM5030T 4R7MNR8	4.7	±20%	52 (43)	3.50 (3.90)	1.90 (2.50)	3.00 (3.40)	0.1
LMXHF5050XAT6R8MNR	NRM5030T 6R8MNR8	6.8	±20%	78 (65)	3.00 (3.40)	1.35 (1.95)	2.25 (2.50)	0.1
LMXHF5050XAT100MNR	NRM5030T 100MNR8	10	±20%	115 (96)	2.50 (2.75)	1.10 (1.60)	1.90 (2.10)	0.1
LMXHF5050XAT220MNR	NRM5030T 220MNR8	22	±20%	228 (190)	1.70 (1.90)	0.80 (1.10)	1.30 (1.50)	0.1
LMXHF5050XAT470MNR	NRM5030T 470MNR8	47	±20%	360 (300)	0.85 (1.00)	0.60 (0.85)	1.00 (1.20)	0.1
LMXHF5050XAT101MNR	NRM5030T 101MNR8	100	±20%	733 (611)	0.55 (0.60)	0.45 (0.60)	0.70 (0.80)	0.1
LMXHF5050XAT221MNR	NRM5030T 221MNR8	220	±20%	1692 (1412)	0.38 (0.41)	0.28 (0.38)	0.46 (0.53)	0.1
LMXHF5050XAT471MNR	NRM5030T 471MNR8	470	±20%	3672 (3060)	0.25 (0.28)	0.17 (0.24)	0.30 (0.35)	0.1

※) The saturation current value (Idc1) is the DC current value having inductance decrease down to 30%. (at 20°C)
 ※) The temperature rise current value (Idc2)① is the DC current value having temperature increase up to 20°C. (at 20°C)
 ※) The temperature rise current value (Idc2)② is the DC current value having temperature increase up to 40°C. (at 20°C)
 ※) The rated current is the DC current value that satisfies both of current value saturation current value and temperature rise current value.

▶ This catalog contains the typical specification only due to the limitation of space. When you consider the purchase of our products, please check our specification. For details of each product (characteristics graph, reliability information, precautions for use, and so on), see our Web site (<http://www.ty-top.com/>).

■ PART NUMBER

● 6060XK type

New part number	Old part number (for reference)	Nominal inductance [μ H]	Inductance tolerance	DC Resistance [m Ω] Max (Typ)	Rated current ※) [A]			Measuring frequency [MHz]
					Saturation current Idc1 Max (Typ)	Temperature rise current① Idc2 Max (Typ)	Temperature rise current② Idc2 Max (Typ)	
LMXHF6060XKL1R0NMRR8	NRM6030T 1R0NMRR8	1	\pm 30%	17 (14)	7.50 (8.10)	3.40 (4.90)	5.80 (6.60)	0.1
LMXHF6060XKL2R2NMRR8	NRM6030T 2R2NMRR8	2.2	\pm 30%	24 (20)	4.80 (6.00)	2.90 (4.00)	4.70 (5.40)	0.1
LMXHF6060XKL4R7MMRR8	NRM6030T 4R7MMRR8	4.7	\pm 20%	36 (30)	3.30 (3.80)	2.30 (3.30)	3.80 (4.40)	0.1
LMXHF6060XKL100MMRR8	NRM6030T 100MMRR8	10	\pm 20%	72 (60)	2.20 (2.60)	1.60 (2.25)	2.70 (3.10)	0.1
LMXHF6060XKL220MMRR8	NRM6030T 220MMRR8	22	\pm 20%	150 (125)	1.50 (1.80)	1.10 (1.60)	1.90 (2.20)	0.1
LMXHF6060XKL470MMRR8	NRM6030T 470MMRR8	47	\pm 20%	320 (270)	1.00 (1.20)	0.76 (1.10)	1.27 (1.48)	0.1
LMXHF6060XKL101MMRR8	NRM6030T 101MMRR8	100	\pm 20%	660 (550)	0.73 (0.85)	0.53 (0.74)	0.88 (0.99)	0.1

● 6060YE type

New part number	Old part number (for reference)	Nominal inductance [μ H]	Inductance tolerance	DC Resistance [m Ω] Max (Typ)	Rated current ※) [A]			Measuring frequency [MHz]
					Saturation current Idc1 Max (Typ)	Temperature rise current① Idc2 Max (Typ)	Temperature rise current② Idc2 Max (Typ)	
LMXHF6060YEL1R0NMRR8	NRM6045T 1R0NMRR8	1	\pm 30%	13 (10)	13.50 (14.50)	4.00 (6.00)	6.20 (7.00)	0.1
LMXHF6060YEL1R5NMRR8	NRM6045T 1R5NMRR8	1.5	\pm 30%	19 (14)	10.00 (11.00)	3.40 (4.70)	5.50 (6.40)	0.1
LMXHF6060YEL2R2NMRR8	NRM6045T 2R2NMRR8	2.2	\pm 30%	23 (18)	8.50 (9.50)	3.00 (4.00)	4.40 (5.10)	0.1
LMXHF6060YEL3R3MMRR8	NRM6045T 3R3MMRR8	3.3	\pm 20%	27.6(23)	7.00 (7.50)	2.50 (3.50)	4.00 (4.50)	0.1
LMXHF6060YEL4R7MMRR8	NRM6045T 4R7MMRR8	4.7	\pm 20%	36 (30)	6.00 (6.50)	2.20 (3.00)	3.60 (3.90)	0.1
LMXHF6060YEL6R8MMRR8	NRM6045T 6R8MMRR8	6.8	\pm 20%	52 (43)	5.10 (5.60)	1.90 (2.60)	3.10 (3.50)	0.1
LMXHF6060YEL100MMRR8	NRM6045T 100MMRR8	10	\pm 20%	60 (50)	4.00 (4.40)	1.80 (2.40)	2.60 (3.20)	0.1
LMXHF6060YEL150MMRR8	NRM6045T 150MMRR8	15	\pm 20%	105 (87)	3.10 (3.50)	1.40 (1.80)	2.15 (2.45)	0.1
LMXHF6060YEL220MMRR8	NRM6045T 220MMRR8	22	\pm 20%	132 (110)	2.50 (3.00)	1.20 (1.60)	1.80 (2.00)	0.1
LMXHF6060YEL330MMRR8	NRM6045T 330MMRR8	33	\pm 20%	216 (180)	1.75 (1.95)	0.75 (0.95)	1.25 (1.35)	0.1
LMXHF6060YEL470MMRR8	NRM6045T 470MMRR8	47	\pm 20%	272 (227)	1.55 (1.70)	0.70 (0.90)	1.20 (1.30)	0.1
LMXHF6060YEL680MMRR8	NRM6045T 680MMRR8	68	\pm 20%	385 (320)	1.20 (1.30)	0.65 (0.85)	1.05 (1.20)	0.1
LMXHF6060YEL101MMRR8	NRM6045T 101MMRR8	100	\pm 20%	600 (475)	1.05 (1.15)	0.55 (0.70)	0.85 (0.95)	0.1
LMXHF6060YEL151MMRR8	NRM6045T 151MMRR8	150	\pm 20%	816 (680)	0.83 (0.90)	0.48 (0.65)	0.76 (0.85)	0.1
LMXHF6060YEL221MMRR8	NRM6045T 221MMRR8	220	\pm 20%	1320 (1100)	0.70 (0.75)	0.35 (0.50)	0.57 (0.65)	0.1
LMXHF6060YEL331MMRR8	NRM6045T 331MMRR8	330	\pm 20%	1872 (1580)	0.55 (0.60)	0.29 (0.39)	0.45 (0.54)	0.1
LMXHF6060YEL471MMRR8	NRM6045T 471MMRR8	470	\pm 20%	2760 (2300)	0.45 (0.50)	0.22 (0.30)	0.38 (0.45)	0.1

※) The saturation current value (Idc1) is the DC current value having inductance decrease down to 30%. (at 20°C)

※) The temperature rise current value (Idc2)① is the DC current value having temperature increase up to 20°C. (at 20°C)

※) The temperature rise current value (Idc2)② is the DC current value having temperature increase up to 40°C. (at 20°C)

※) The rated current is the DC current value that satisfies both of current value saturation current value and temperature rise current value.

■ Derating of Rated Current

● LMXH series

Derating of current is necessary for LMXH series depending on ambient temperature.

Please refer to the chart shown below for appropriate derating of current.

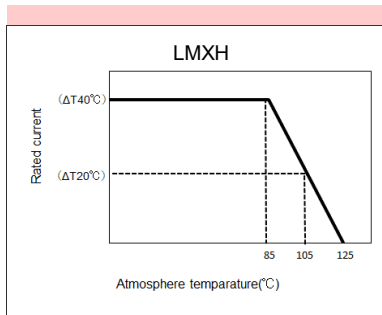

▶ This catalog contains the typical specification only due to the limitation of space. When you consider the purchase of our products, please check our specification. For details of each product (characteristics graph, reliability information, precautions for use, and so on), see our Web site (<http://www.ty-top.com/>).

Wire-wound Ferrite Power Inductors LSXN/LSXP/LCXN/LCXP/LBXN/LBXP/
LLXN/LLXP/LMXN/LMXP series

Wire-wound Ferrite Power Inductors LAXH/LCXH/LBXH/LMXH series

Wire-wound Ferrite Inductors for Class D Amplifier LCXA

■ PACKAGING

① Minimum Quantity

Type	Standard Quantity [pcs]
	Tape & Reel
2020KK	2500
2020MK	2500
2424KK	2500
2424MK	2500
3030KK	2000
3030MK	2000
3030QK	2000
4040KK	5000
4040MK	4500
4040TK	3500
4040WK	700

Type	Standard Quantity [pcs]
	Tape & Reel
5050KK	1000
5050MK	1000
5050PK	1000
5050WB	800
5050WK	800
5050WD	2500
5050WE	2500
5050XK	500
5050XA	500
5050YA	1500
5050YK	1500
6060KK	1000
6060MK	1000
6060PK	1000
6060WK	2500
6060WH	2000
6060XK	2000
6060YE	1500
8080XK	1000
8080YK	1000
8080YB	1000

② Tape Material

● Embossed Tape

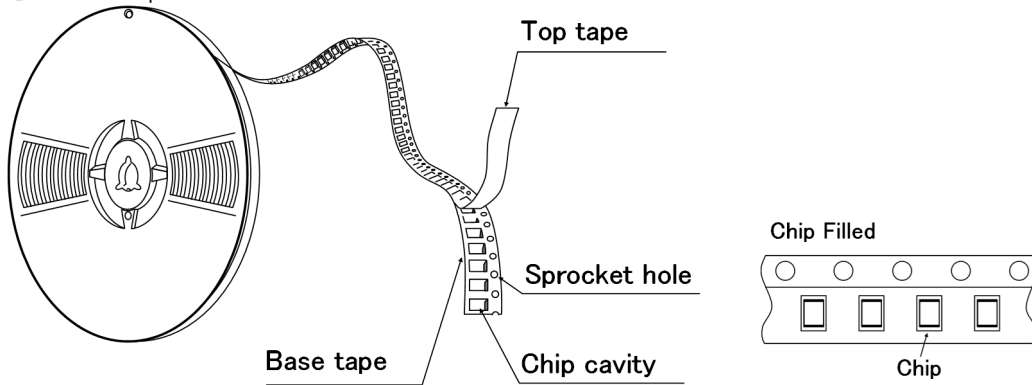

③ Taping dimensions

● Embossed tape 8mm wide (0.315 inches wide)

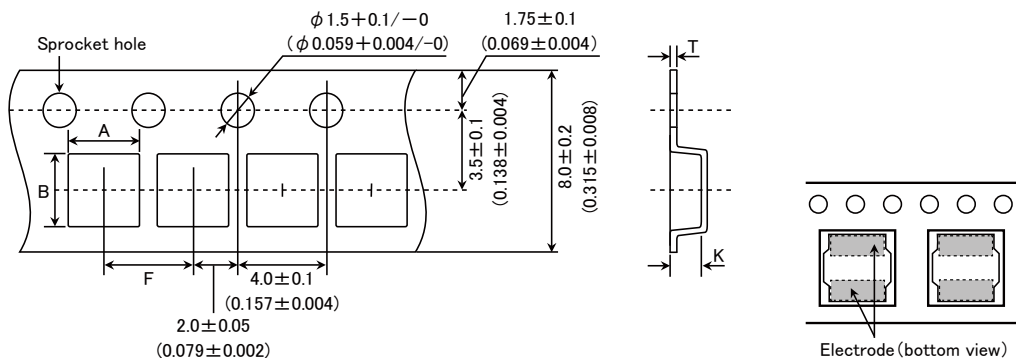

▶ This catalog contains the typical specification only due to the limitation of space. When you consider the purchase of our products, please check our specification. For details of each product (characteristics graph, reliability information, precautions for use, and so on), see our Web site (<http://www.ty-top.com/>).

Type	Chip cavity		Insertion pitch	Tape thickness	
	A	B		T	K
2020KK 2020MK	2.2±0.1 (0.102±0.004)	2.2±0.1 (0.102±0.004)	4.0±0.1 (0.157±0.004)	0.25±0.05 (0.009±0.002)	1.3±0.1 (0.051±0.004)
2424KK 2424MK	2.6±0.1 (0.087±0.004)	2.6±0.1 (0.102±0.004)		0.25±0.05 (0.009±0.002)	1.3±0.1 (0.051±0.004)
3030KK	3.2±0.1 (0.126±0.004)	3.2±0.1 (0.126±0.004)		0.3±0.05 (0.012±0.002)	1.4±0.1 (0.055±0.004)
3030MK					1.6±0.1 (0.063±0.004)
3030QK					1.9±0.1 (0.075±0.004)

Unit: mm (inch)

● Embossed tape 12mm wide (0.47 inches wide)

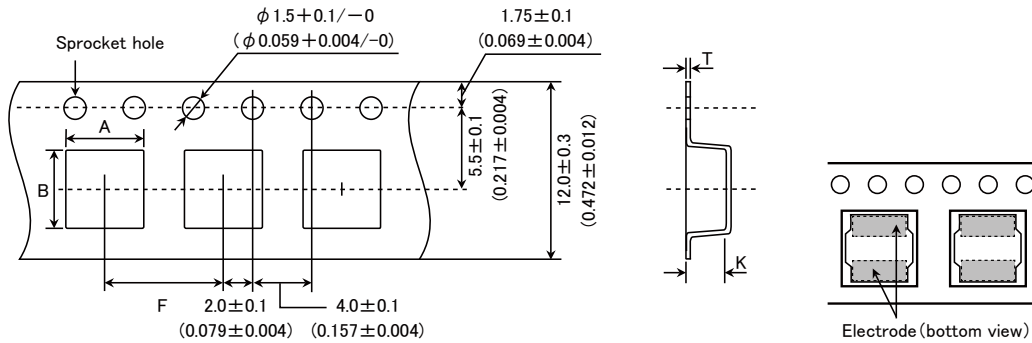

Type	Chip cavity		Insertion pitch	Tape thickness			
	A	B		T	K		
4040KK	4.3±0.1 (0.169±0.004)	4.3±0.1 (0.169±0.004)	8.0±0.1 (0.315±0.004)	0.3±0.1 (0.012±0.004)	1.4±0.1 (0.055±0.004)		
4040MK					1.6±0.1 (0.063±0.004)		
4040TK 4040WK					2.1±0.1 (0.083±0.004)		
5050KK	5.25±0.1 (0.207±0.004)	5.25±0.1 (0.207±0.004)			1.4±0.1 (0.055±0.004)		
5050MK					1.4±0.1 (0.055±0.004)		
5050PK					1.6±0.1 (0.063±0.004)		
5050WB 5050WK					2.3±0.1 (0.091±0.004)		
5050WD 5050WE					2.7±0.1 (0.106±0.004)		
5050XK 5050XA	5.15±0.1 (0.203±0.004)	5.15±0.1 (0.203±0.004)			0.4±0.1 (0.016±0.004)	0.4±0.1 (0.016±0.004)	3.2±0.1 (0.126±0.004)
5050YK 5050YA	5.15±0.1 (0.203±0.004)	5.15±0.1 (0.203±0.004)					4.2±0.1 (0.165±0.004)
6060KK	6.3±0.1 (0.248±0.004)	6.3±0.1 (0.248±0.004)	1.4±0.1 (0.055±0.004)				
6060MK			1.6±0.1 (0.063±0.004)				
6060PK			1.6±0.1 (0.063±0.004)				
6060WK			2.3±0.1 (0.090±0.004)				
6060WH 6060XK			3.1±0.1 (0.122±0.004)				
6060YE			4.7±0.1 (0.185±0.004)				
			4.7±0.1 (0.185±0.004)				

Unit: mm (inch)

► This catalog contains the typical specification only due to the limitation of space. When you consider the purchase of our products, please check our specification. For details of each product (characteristics graph, reliability information, precautions for use, and so on), see our Web site (<http://www.ty-top.com/>).

● Embossed tape 16mm wide (0.63 inches wide)

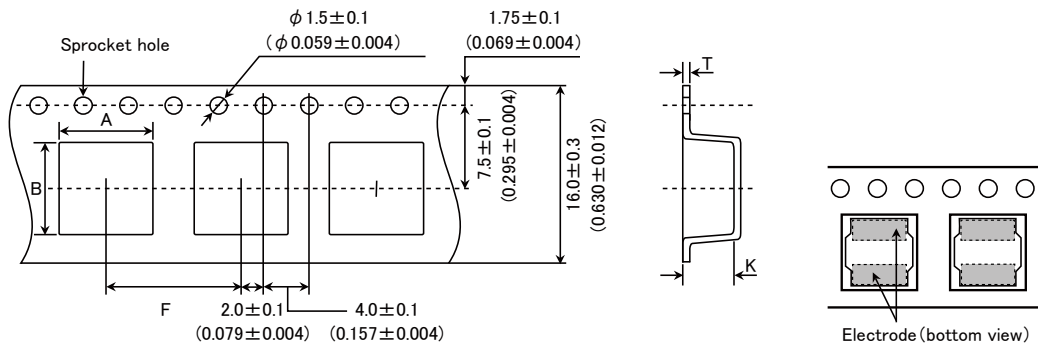

Type	Chip cavity		Insertion pitch F	Tape thickness	
	A	B		T	K
8080XK	8.3±0.1 (0.327±0.004)	8.3±0.1 (0.327±0.004)	12.0±0.1 (0.472±0.004)	0.5±0.1 (0.020±0.004)	3.4±0.1 (0.134±0.004)
8080YK					4.5±0.1 (0.177±0.004)
8080YB					4.5±0.1 (0.177±0.004)

Unit: mm (inch)

④ Leader and Blank portion

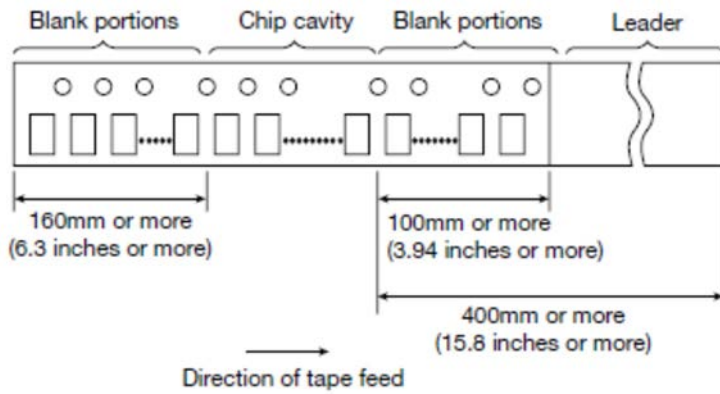

⑤ Reel size

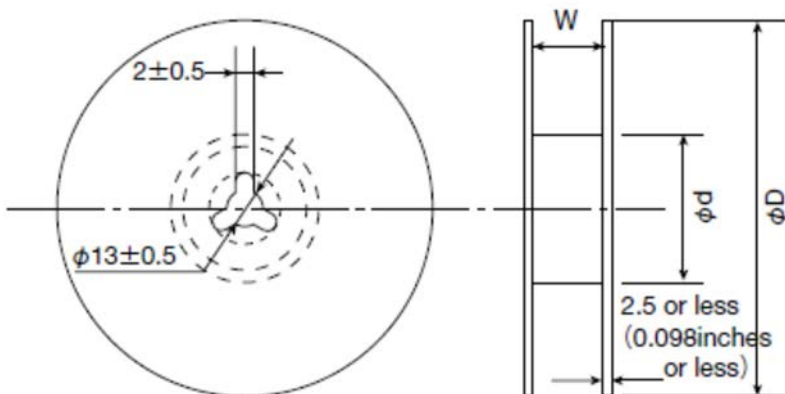

► This catalog contains the typical specification only due to the limitation of space. When you consider the purchase of our products, please check our specification. For details of each product (characteristics graph, reliability information, precautions for use, and so on), see our Web site (<http://www.ty-top.com/>).

Type	Reel size (Reference values)		
	ϕD	ϕd	W
2020KK	180±0.5 (7.087±0.019)	60±1.0 (2.36±0.04)	10.0±1.5 (0.394±0.059)
2020MK			
2424KK			
2424MK			
3030KK			
3030MK			
3030QK			
4040WK	180±3.0 (7.087±0.118)	60±2.0 (2.36±0.08)	14.0±1.5 (0.551±0.059)
5050KK			
5050MK			
5050PK			
5050WB			
5050WK			
5050XK			
5050XA			
6060KK			
6060MK			
6060PK			

Unit: mm (inch)

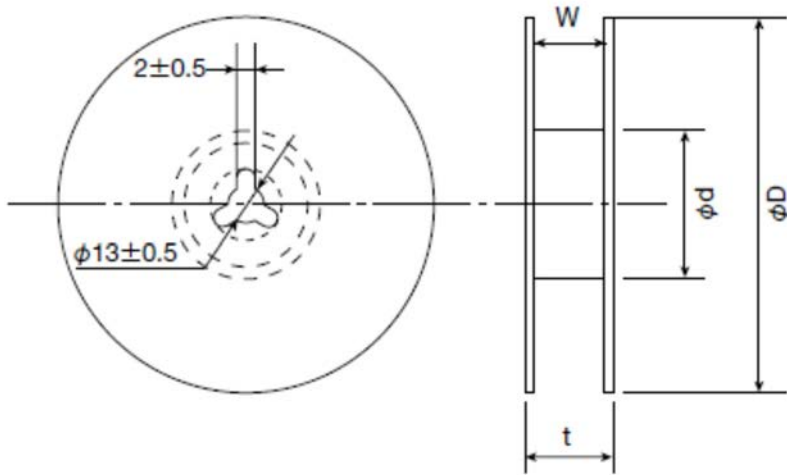

Type	Reel size (Reference values)			
	ϕD	ϕd	t (max.)	W
4040KK	330±3.0 (12.99±0.118)	80±2.0 (3.15±0.078)	18.5 (0.72)	13.5±1.0 (0.531±0.04)
4040MK				
4040TK				
5050WD				
5050WE				
5050YA				
5050YK				
6060WK				
6060WH				
6060XK				
6060YE				
8080XK			22.5 (0.89)	17.5±1.0 (0.689±0.04)
8080YK				
8080YB				
8080YB				

Unit: mm (inch)

⑥ Top Tape Strength

The top tape requires a peel-off force of 0.1 to 1.3N in the direction of the arrow as illustrated below.

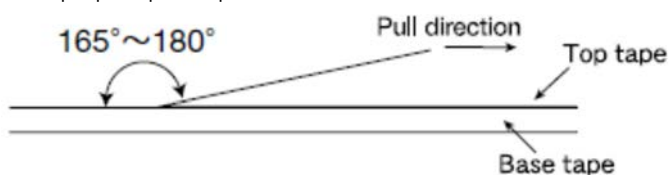

**Wire-wound Ferrite Power Inductors LBXH series
for Telecommunications Infrastructure and Industrial Equipment**
**Wire-wound Ferrite Power Inductors LMXH series
for Medical Devices classified as GHTF Class C (Japan Class III)**

■ RELIABILITY DATA

1. Operating Temperature Range

Specified Value −40~ +125°C (Including self-generated heat)

Test Methods and Remarks Including self-generated heat

2. Storage Temperature Range

Specified Value −40~ +125°C

Test Methods and Remarks −5 to 40°C for the product with taping.

3. Rated current

Specified Value Within the specified tolerance

4. Inductance

Specified Value Within the specified tolerance

Test Methods and Remarks Measuring equipment : LCR Meter (HP 4285A or equivalent)
 Measuring frequency : 100kHz, 1V

5. DC Resistance

Specified Value Within the specified tolerance

Test Methods and Remarks Measuring equipment : DC ohmmeter (HIOKI 3227 or equivalent)

6. Temperature characteristic

Specified Value Inductance change : Within ±20%

Test Methods and Remarks Measurement of inductance shall be taken at temperature range within −40°C~ +125°C.
 With reference to inductance value at +20°C., change rate shall be calculated.
 Change of maximum inductance deviation in step 1 to 5

Step	Temperature (°C)
1	20
2	Minimum operating temperature
3	20 (Standard temperature)
4	Maximum operating temperature
5	20

▶ This catalog contains the typical specification only due to the limitation of space. When you consider the purchase of our products, please check our specification.
 For details of each product (characteristics graph, reliability information, precautions for use, and so on), see our Web site (<http://www.ty-top.com/>).

7. Resistance to flexure of substrate

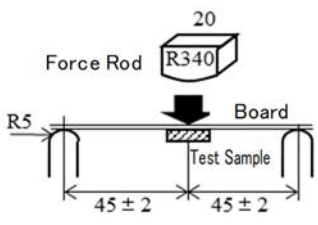
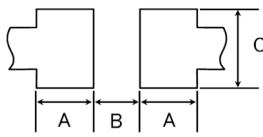
Specified Value	No damage																				
Test Methods and Remarks	<p>The test samples shall be soldered to the test board by the reflow. As illustrated below, apply force in the direction of the arrow indicating until deflection of the test board reaches to 2 mm.</p> <p>Test board size : 100 × 40 × 1.6 mm Test board material : glass epoxy-resin Solder cream thickness : 0.10mm (3030~4040 type) : 0.15mm (5050~6060 type)</p>																				
	 <p style="text-align: right;">Unit: mm</p>																				
	<p>Land dimension</p>  <table border="1" data-bbox="606 526 997 683"> <thead> <tr> <th>Type</th> <th>A</th> <th>B</th> <th>C</th> </tr> </thead> <tbody> <tr> <td>3030</td> <td>1.3</td> <td>1.0</td> <td>2.7</td> </tr> <tr> <td>4040</td> <td>1.5</td> <td>1.8</td> <td>3.5</td> </tr> <tr> <td>5050</td> <td>1.9</td> <td>2.3</td> <td>3.8</td> </tr> <tr> <td>6060</td> <td>2.4</td> <td>2.6</td> <td>4.8</td> </tr> </tbody> </table>	Type	A	B	C	3030	1.3	1.0	2.7	4040	1.5	1.8	3.5	5050	1.9	2.3	3.8	6060	2.4	2.6	4.8
Type	A	B	C																		
3030	1.3	1.0	2.7																		
4040	1.5	1.8	3.5																		
5050	1.9	2.3	3.8																		
6060	2.4	2.6	4.8																		

8. Adhesion of terminal electrode

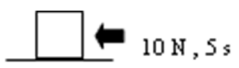
Specified Value	Shall not come off PC board
Test Methods and Remarks	<p>The test samples shall be soldered to the test board by the reflow.</p> <p>Applied force : 10N Duration : 5s. Solder cream thickness : 0.10mm (3030~4040 type) : 0.15mm (5050~6060 type)</p>
	

9. Resistance to vibration

Specified Value	Inductance change : Within ±10% No significant abnormality in appearance.													
Test Methods and Remarks	The test samples shall be soldered to the test board by the reflow. Then it shall be submitted to below test conditions.													
	<table border="1" data-bbox="311 1243 1149 1422"> <tr> <td>Frequency Range</td> <td colspan="2">10~55Hz</td> </tr> <tr> <td>Total Amplitude</td> <td colspan="2">1.5mm (May not exceed acceleration 196m/s²)</td> </tr> <tr> <td>Sweeping Method</td> <td colspan="2">10Hz to 55Hz to 10Hz for 1min.</td> </tr> <tr> <td rowspan="3">Time</td> <td>X</td> <td rowspan="3">For 2 hours on each X, Y, and Z axis.</td> </tr> <tr> <td>Y</td> </tr> <tr> <td>Z</td> </tr> </table> <p>Recovery : At least 2hrs of recovery under the standard condition after the test, followed by the measurement within 48hrs.</p>	Frequency Range	10~55Hz		Total Amplitude	1.5mm (May not exceed acceleration 196m/s ²)		Sweeping Method	10Hz to 55Hz to 10Hz for 1min.		Time	X	For 2 hours on each X, Y, and Z axis.	Y
Frequency Range	10~55Hz													
Total Amplitude	1.5mm (May not exceed acceleration 196m/s ²)													
Sweeping Method	10Hz to 55Hz to 10Hz for 1min.													
Time	X	For 2 hours on each X, Y, and Z axis.												
	Y													
	Z													

10. Solderability

Specified Value	At least 90% of surface of terminal electrode is covered by new solder.			
Test Methods and Remarks	The test samples shall be dipped in flux, and then immersed in molten solder as shown in below table. Flux : Ethanol solution containing rosin 25%.			
	<table border="1" data-bbox="295 1646 718 1713"> <tr> <td>Solder Temperature</td> <td>245 ± 5°C</td> </tr> <tr> <td>Time</td> <td>5 ± 1.0 sec.</td> </tr> </table> <p>※Immersion depth : All sides of mounting terminal shall be immersed.</p>	Solder Temperature	245 ± 5°C	Time
Solder Temperature	245 ± 5°C			
Time	5 ± 1.0 sec.			

11. Resistance to soldering heat

Specified Value	Inductance change : Within ±10% No significant abnormality in appearance.
Test Methods and Remarks	The test sample shall be exposed to reflow oven at 230 ± 5°C for 40 seconds, with peak temperature at 260 ± 5°C for 5 seconds, 2 times. Test board material : glass epoxy-resin Test board thickness : 1.0mm

▶ This catalog contains the typical specification only due to the limitation of space. When you consider the purchase of our products, please check our specification. For details of each product (characteristics graph, reliability information, precautions for use, and so on), see our Web site (<http://www.ty-top.com/>).

12. Thermal shock

Specified Value	Inductance change : Within $\pm 10\%$ No significant abnormality in appearance.																		
Test Methods and Remarks	The test samples shall be soldered to the test board by the reflow. The test samples shall be placed at specified temperature for specified time by step 1 to step 4 as shown in below table in sequence. The temperature cycle shall be repeated 1000 cycles. <table border="1" style="margin-left: 20px;"> <thead> <tr> <th colspan="3">Conditions of 1 cycle</th> </tr> <tr> <th>段階</th> <th>Temperature ($^{\circ}\text{C}$)</th> <th>Duration (min)</th> </tr> </thead> <tbody> <tr> <td>1</td> <td>-40 ± 3</td> <td>30 ± 3</td> </tr> <tr> <td>2</td> <td>Room temperature</td> <td>Within 3</td> </tr> <tr> <td>3</td> <td>$+105 \pm 3$</td> <td>30 ± 3</td> </tr> <tr> <td>4</td> <td>Room temperature</td> <td>Within 3</td> </tr> </tbody> </table>	Conditions of 1 cycle			段階	Temperature ($^{\circ}\text{C}$)	Duration (min)	1	-40 ± 3	30 ± 3	2	Room temperature	Within 3	3	$+105 \pm 3$	30 ± 3	4	Room temperature	Within 3
Conditions of 1 cycle																			
段階	Temperature ($^{\circ}\text{C}$)	Duration (min)																	
1	-40 ± 3	30 ± 3																	
2	Room temperature	Within 3																	
3	$+105 \pm 3$	30 ± 3																	
4	Room temperature	Within 3																	

13. Damp heat

Specified Value	Inductance change : Within $\pm 10\%$ No significant abnormality in appearance.						
Test Methods and Remarks	The test samples shall be soldered to the test board by the reflow. The test samples shall be placed in thermostatic oven set at specified temperature and humidity as shown in below table. <table border="1" style="margin-left: 20px;"> <tbody> <tr> <td>Temperature</td> <td>$85 \pm 2^{\circ}\text{C}$</td> </tr> <tr> <td>Humidity</td> <td>85%RH</td> </tr> <tr> <td>Time</td> <td>1000 + 24 / - 0 hour</td> </tr> </tbody> </table>	Temperature	$85 \pm 2^{\circ}\text{C}$	Humidity	85%RH	Time	1000 + 24 / - 0 hour
Temperature	$85 \pm 2^{\circ}\text{C}$						
Humidity	85%RH						
Time	1000 + 24 / - 0 hour						

14. Low temperature life test

Specified Value	Inductance change : Within $\pm 10\%$ No significant abnormality in appearance.				
Test Methods and Remarks	The test samples shall be soldered to the test board by the reflow. After that, the test samples shall be placed at test conditions as shown in below table. <table border="1" style="margin-left: 20px;"> <tbody> <tr> <td>Temperature</td> <td>$-40 \pm 2^{\circ}\text{C}$</td> </tr> <tr> <td>Time</td> <td>1000 + 24 / - 0 hour</td> </tr> </tbody> </table>	Temperature	$-40 \pm 2^{\circ}\text{C}$	Time	1000 + 24 / - 0 hour
Temperature	$-40 \pm 2^{\circ}\text{C}$				
Time	1000 + 24 / - 0 hour				

15. High temperature life test

Specified Value	Inductance change : Within $\pm 10\%$ No significant abnormality in appearance.				
Test Methods and Remarks	The test samples shall be soldered to the test board by the reflow. After that, the test samples shall be placed at test conditions as shown in below table. <table border="1" style="margin-left: 20px;"> <tbody> <tr> <td>Temperature</td> <td>$125 \pm 3^{\circ}\text{C}$</td> </tr> <tr> <td>Time</td> <td>1000 hour</td> </tr> </tbody> </table>	Temperature	$125 \pm 3^{\circ}\text{C}$	Time	1000 hour
Temperature	$125 \pm 3^{\circ}\text{C}$				
Time	1000 hour				

16. Loading at high temperature life test

Specified Value	Inductance change : Within $\pm 10\%$ No significant abnormality in appearance.						
Test Methods and Remarks	The test samples shall be soldered to the test board by the reflow soldering. <table border="1" style="margin-left: 20px;"> <tbody> <tr> <td>Temperature</td> <td>1) $85 \pm 2^{\circ}\text{C}$ 2) $105 \pm 3^{\circ}\text{C}$</td> </tr> <tr> <td>Applied current</td> <td>1) Rated current ($+40^{\circ}\text{C}$) 2) Rated current ($+20^{\circ}\text{C}$)</td> </tr> <tr> <td>Time</td> <td>1000 + 24 / - 0 hour</td> </tr> </tbody> </table>	Temperature	1) $85 \pm 2^{\circ}\text{C}$ 2) $105 \pm 3^{\circ}\text{C}$	Applied current	1) Rated current ($+40^{\circ}\text{C}$) 2) Rated current ($+20^{\circ}\text{C}$)	Time	1000 + 24 / - 0 hour
Temperature	1) $85 \pm 2^{\circ}\text{C}$ 2) $105 \pm 3^{\circ}\text{C}$						
Applied current	1) Rated current ($+40^{\circ}\text{C}$) 2) Rated current ($+20^{\circ}\text{C}$)						
Time	1000 + 24 / - 0 hour						

17. Standard condition

Specified Value	Standard test condition : Unless otherwise specified, temperature is $20 \pm 15^{\circ}\text{C}$ and $65 \pm 20\%$ of relative humidity. When there is any question concerning measurement result: In order to provide correlation data, the test shall be condition of $20 \pm 2^{\circ}\text{C}$ of temperature, $65 \pm 5\%$ relative humidity. Inductance is in accordance with our measured value.
-----------------	--

Wire-wound Ferrite Power Inductors LAYP series for Automotive Powertrain and safety
 Wire-wound Ferrite Power Inductors LAXH series for Automotive Powertrain and safety
 Wire-wound Ferrite Power Inductors LCXN/LCXP series for Automotive Body & Chassis and Infotainment
 Wire-wound Ferrite Power Inductors LCXH series for Automotive Body & Chassis and Infotainment
 Wire-wound Ferrite Inductors for Class D Amplifier LCXA for Automotive Body & Chassis and Infotainment
 Wire-wound Ferrite Power Inductors LCRN series for Automotive Body & Chassis and Infotainment
 Wire-wound Ferrite Power Inductors LBXN/LBXP series
 for Telecommunications Infrastructure and Industrial Equipment
 Wire-wound Ferrite Power Inductors LBXH series
 for Telecommunications Infrastructure and Industrial Equipment
 Wire-wound Ferrite Power Inductors LBRN series
 for Telecommunications Infrastructure and Industrial Equipment
 Wire-wound Ferrite Power Inductors LMXN/LMXP series
 for Medical Devices classified as GHTF Class C (Japan Class III)
 Wire-wound Ferrite Power Inductors LMXH series
 for Medical Devices classified as GHTF Class C (Japan Class III)
 Wire-wound Ferrite Power Inductors LMRN series
 for Medical Devices classified as GHTF Class C (Japan Class III)

■ PRECAUTIONS

1. Circuit Design	
Precautions	<ul style="list-style-type: none"> ◆ Verification of operating environment, electrical rating and performance <ol style="list-style-type: none"> 1. A malfunction in medical equipment, spacecraft, nuclear reactors, etc. may cause serious harm to human life or have severe social ramifications. As such, any inductors to be used in such equipment may require higher safety and/or reliability considerations and should be clearly differentiated from components used in general purpose applications. 2. When inductors are used in places where dew condensation develops and/or where corrosive gas such as hydrogen sulfide, sulfurous acid, or chlorine exists in the air, characteristic deterioration may occur. Please do not use inductors under such environmental conditions. ◆ Operating Current (Verification of Rated current) <ol style="list-style-type: none"> 1. The operating current including inrush current for inductors must always be lower than their rated values. 2. Do not apply current in excess of the rated value because the inductance may be reduced due to the magnetic saturation effect. ◆ Temperature rise <p style="margin-left: 20px;">Temperature rise of power choke coil depends on the installation condition in end products. Make sure that temperature rise of power choke coils in actual end products is within the specified temperature range.</p>
2. PCB Design	
Precautions	<ul style="list-style-type: none"> ◆ Land pattern design <ol style="list-style-type: none"> 1. Please refer to a recommended land pattern. 2. There is stress, which has been caused by distortion of a PCB, to the inductor. (LAXH/LCXN/LCXP/LBXN/LBXP/LMXN/LMXP, LCXH/LCXA/LBXH/LMXH) 3. Please consider the arrangement of parts on a PCB. (LAXH/LCXN/LCXP/LBXN/LBXP/LMXN/LMXP, LCXH/LCXA/LBXH/LMXH)
Technical considerations	<ul style="list-style-type: none"> ◆ Land pattern design <p>Surface Mounting</p> <ol style="list-style-type: none"> 1. Mounting and soldering conditions should be checked beforehand. 2. Applicable soldering process to this products is reflow soldering only. 3. Please use the recommended land pattern shown as below. Electrical characteristics and the mounting ability of the product are being considered in the recommended land pattern. If a PCB is designed with other dimensions, defective soldering and stress to a product may occur due to misalignment. The performance of the product may not be brought out. If an adopted land pattern is different from the recommended land pattern, stress to the product will increase. It may cause cracks or defective electrical characteristics of the product. Please conduct validation completely before studying adoption of this product and please judge the pros and cons of adoption of this product with taking on responsibility. (LAXH/LCXN/LCXP/LBXN/LBXP/LMXN/LMXP, LCXH/LCXA/LBXH/LMXH) 4. As coefficients of thermal expansion between an inductor and a PCB differs, cracks may occur on a ferrite core when thermal stress is applied to them after mounting an inductor. (Please refer to the drawings below.) Please conduct validation completely before studying adoption of this product and please judge the pros and cons of adoption of this product with taking on responsibility. (LAXH/LCXN/LCXP/LBXN/LBXP/LMXN/LMXP, LCXH/LCXA/LBXH/LMXH)

▶ This catalog contains the typical specification only due to the limitation of space. When you consider the purchase of our products, please check our specification. For details of each product (characteristics graph, reliability information, precautions for use, and so on), see our Web site (<http://www.ty-top.com/>)

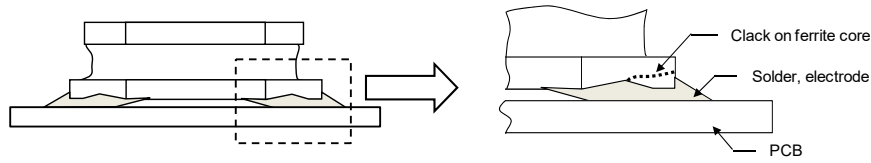

5. SMD inductors should be located to minimize any possible mechanical stresses from board warp or deflection. When splitting the PC board after mounting inductors and other components, care is required so as not to give any stresses of deflection or twisting to the board.

(LAXH/LCXN/LCXP/LBXN/LBXP/LMXN/LMXP, LCXH/LCXA/LBXH/LMXH)

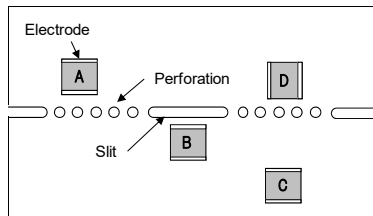

A product tends to undergo stress in order "A>C>B≡D". Please consider the layouts of a product to minimize any stresses.

3. Considerations for automatic placement

Precautions	<ul style="list-style-type: none"> ◆ Adjustment of mounting machine <ol style="list-style-type: none"> 1. Excessive impact load should not be imposed on the products when mounting onto the PC boards. 2. Mounting and soldering conditions should be checked beforehand.
Technical considerations	<ul style="list-style-type: none"> ◆ Adjustment of mounting machine <ol style="list-style-type: none"> 1. When installing products, care should be taken not to apply distortion stress as it may deform the products. 2. Stress may be applied to a product with a warp or a twist in handling of the product. Please conduct validation completely before studying adoption of this product and please judge the pros and cons of adoption of this product with taking on responsibility. (LAXH/LCXN/LCXP/LBXN/LBXP/LMXN/LMXP, LCXH/LCXA/LBXH/LMXH) <div style="display: flex; justify-content: space-around;"> <div style="text-align: center;"> <p><Wrap></p> </div> <div style="text-align: center;"> <p><Twist></p> </div> </div>

4. Soldering

Precautions	<ul style="list-style-type: none"> ◆ Reflow soldering <ol style="list-style-type: none"> 1. Please contact any of our offices for a reflow soldering, and refer to the recommended condition specified. 2. The product shall be used reflow soldering only. 3. Please do not add any stress to a product until it returns in normal temperature after reflow soldering. ◆ Lead free soldering <ol style="list-style-type: none"> 1. When using products with lead free soldering, we request to use them after confirming adhesion, temperature of resistance to soldering heat, soldering etc sufficiently. ◆ Recommended conditions for using a soldering iron(Repair) <ul style="list-style-type: none"> • Put the soldering iron on the land-pattern. • Soldering iron's temperature - Below 350°C • Duration - 3 seconds or less • The soldering iron should not directly touch the inductor.
Technical considerations	<ul style="list-style-type: none"> ◆ Reflow soldering <ol style="list-style-type: none"> 1. If products are used beyond the range of the recommended conditions, heat stresses may deform the products, and consequently degrade the reliability of the products. Recommended reflow condition (Pb free solder) <u>LAXH/LCXN/LCXP/LBXN/LBXP/LMXN/LMXP,</u> <u>LCXH/LCXA/LBXH/LMXH, LCRN/LBRN/LMRN</u> <div style="display: flex; justify-content: space-around;"> <div style="text-align: center;"> </div> <div style="text-align: center;"> </div> </div>

▶ This catalog contains the typical specification only due to the limitation of space. When you consider the purchase of our products, please check our specification. For details of each product (characteristics graph, reliability information, precautions for use, and so on), see our Web site (<http://www.ty-top.com/>)

5. Cleaning	
Precautions	<ul style="list-style-type: none"> ◆ Cleaning conditions 1. Washing by supersonic waves shall be avoided.
Technical considerations	<ul style="list-style-type: none"> ◆ Cleaning conditions 1. If washed by supersonic waves, the products might be broken.
6. Handling	
Precautions	<ul style="list-style-type: none"> ◆ Handling 1. Keep the product away from all magnets and magnetic objects. ◆ Breakaway PC boards (splitting along perforations) 1. When splitting the PC board after mounting product, care should be taken not to give any stresses of deflection or twisting to the board. 2. Board separation should not be done manually, but by using the appropriate devices. ◆ Mechanical considerations 1. Please do not give the product any excessive mechanical shocks. 2. Please do not add any shock and power to a product in transportation. ◆ Pick-up pressure 1. Please do not push to add any pressure to a winding part. Please do not give any shock and push into a ferrite core exposure part. ◆ Packing 1. Please avoid accumulation of a packing box as much as possible.
Technical considerations	<ul style="list-style-type: none"> ◆ Handling 1. There is a case that a characteristic varies with magnetic influence. ◆ Breakaway PC boards (splitting along perforations) 1. The position of the product on PCBs shall be carefully considered to minimize the stress caused from splitting of the PCBs. ◆ Mechanical considerations 1. There is a case to be damaged by a mechanical shock. 2. There is a case to be broken by the handling in transportation. ◆ Pick-up pressure 1. Damage and a characteristic can vary with an excessive shock or stress. ◆ Packing 1. If packing boxes are accumulated, that could cause a deformation on packing tapes or a damage on the products.
7. Storage conditions	
Precautions	<ul style="list-style-type: none"> ◆ Storage 1. To maintain the solderability of terminal electrodes and to keep the packing material in good condition, temperature and humidity in the storage area should be controlled. <ul style="list-style-type: none"> ▪ Storage conditions Ambient temperature : $-5\sim 40^{\circ}\text{C}$ Humidity : Below 70% RH ▪ The recommended ambient temperature is below 30°C. Even under ideal storage conditions, solderability of products electrodes may decrease as time passes. For this reason, product should be used within 6 months from the time of delivery. In case of storage over 6 months, solderability shall be checked before actual usage.
Technical considerations	<ul style="list-style-type: none"> ◆ Storage 1. Under a high temperature and humidity environment, problems such as reduced solderability caused by oxidation of terminal electrodes and deterioration of taping/packaging materials may take place.

Mouser Electronics

Authorized Distributor

Click to View Pricing, Inventory, Delivery & Lifecycle Information:

[TAIYO YUDEN:](#)

[LMXHF5050XAT680MMR](#) [LMXHF5050XAT150MMR](#)