

NOTES:

1. CABLE RANGE: $\phi 0.217-0.441$ [5.5-11.2].
2. RECOMMENDED MOUNTING HOLE: $\phi 0.813$ [20.64].
- Ⓑ 3. IP68 RATED WHEN PROPERLY ASSEMBLED. IMMERSED IN 1.8M WATER FOR 24 HOURS.
4. ALL PARTS SHIPPED ASSEMBLED.
5. MATERIALS:
 SEAL NUT, CLAMP NUT, HEX NUT - BLACK, THERMOPLASTIC UL746C (F1) UV RATED
 O-RING AND SEAL RING - BLACK, SILICONE. Ⓒ
6. THIS PRODUCT IS RoHS COMPLIANT.

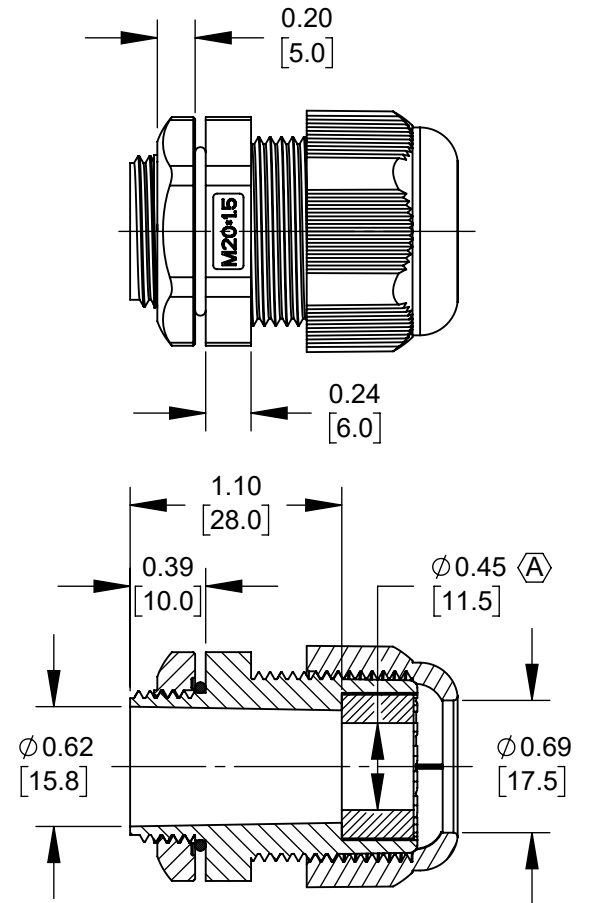
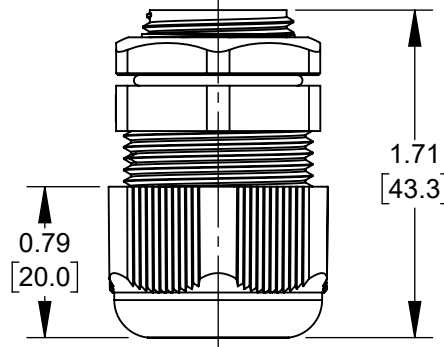
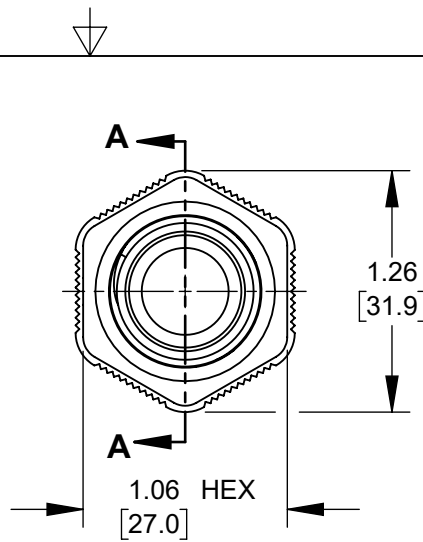

SECTION A-A

CUSTOMER DRAWING

					THIS DRAWING DESCRIBES A DESIGN CONSIDERED PROPRIETARY IN NATURE, DEVELOPED AND MANUFACTURED BY SWITCHCRAFT INC. AND IS RELEASED ON A CONFIDENTIAL BASIS FOR IDENTIFICATION PURPOSES ONLY.					
					SIZE	WIDTH	MULT	LBS/M	TEMPER	
					FINISH			MATERIAL		
					SPEC No.			SPEC No.		
					FIRST USED ON		SCALE 1:1			
C	28375	03/30/21	PC	TJK	DATE DRAWN	BY	CHKD	APVD	Switchcraft®	
B	28315	09/09/20	PC	TJK	5/4/20	FM	FM	TJK		
A	28308	07/31/20	PC	TJK	5/4/20	FM	5/4/20	7/10/20		
REV	ECO NUMBER	DATE	BY	APVD	NAME M20 X 1.5 CABLE GLAND, CABLE RANGE Ø5.5 - 11.2mm				REV	
REVISIONS					DO NOT SCALE DRAWING				REV	C
					PART No. CGM20N44					



Mouser Electronics

Authorized Distributor

Click to View Pricing, Inventory, Delivery & Lifecycle Information:

[Switchcraft:](#)

[CGM20N44](#)