

Product availability: Stock - Normally stocked in distribution facility



Main

Range of product	Modicon TM3
Product or component type	Discrete output module
Range compatibility	Modicon M221 Modicon M241 Modicon M251
Discrete output type	Relay normally open
Discrete output number	8
Discrete output logic	Positive or negative
Discrete output voltage	24 V DC relay output 240 V AC
Discrete output current	2000 mA relay output

Complementary

Discrete I/O number	8
Current consumption	5 mA at 5 V DC via bus connector at state off 0 mA at 24 V DC via bus connector at state off 40 mA at 24 V DC via bus connector at state on 30 mA at 5 V DC via bus connector at state on
Response time	10 ms turn-on 5 ms turn-off
Mechanical durability	20000000 cycles
Minimum load	10 mA at 5 V DC relay output
Local signalling	1 LED per channel green for output status
Electrical connection	Removable spring terminal block pitch 5.08 mm with 11 terminal(s) of 2.5 mm ² connection capacity for outputs
Insulation	2300 V AC between output and internal logic 750 V AC between outputs 1500 V AC between output groups
Marking	CE
Mounting support	Top hat type TH35-15 rail conforming to IEC 60715 Top hat type TH35-7.5 rail conforming to IEC 60715 Plate or panel with fixing kit
Height	3.54 in (90 mm)
Depth	3.33 in (84.6 mm)
Width	1.08 in (27.4 mm)
Product weight	0.24 lb(US) (0.11 kg)

Environment

Standards	EN/IEC 61131-2 EN/IEC 61010-2-201
Product certifications	C-Tick cULus
Resistance to electrostatic discharge	4 kV (on contact) conforming to EN/IEC 61000-4-2 8 kV (in air) conforming to EN/IEC 61000-4-2
Resistance to electromagnetic fields	9.14 V/yd (10 V/m) at 80 MHz...1 GHz conforming to EN/IEC 61000-4-3 2.74 V/yd (3 V/m) at 1.4 GHz...2 GHz conforming to EN/IEC 61000-4-3 0.91 V/yd (1 V/m) at 2 GHz...3 GHz conforming to EN/IEC 61000-4-3
Resistance to magnetic fields	30 A/m 50/60 Hz conforming to EN/IEC 61000-4-8
Resistance to fast transients	2 kV relay output conforming to EN/IEC 61000-4-4
Surge withstand	1 kV I/O (DC) in common mode conforming to EN/IEC 61000-4-5

Resistance to conducted disturbances	10 Vrmsat 0.15...80 MHz conforming to EN/IEC 61000-4-6 3 Vrmsat spot frequency (2, 3, 4, 6.2, 8.2, 12.6, 16.5, 18.8, 22, 25 MHz) conforming to Marine specification (LR, ABS, DNV, GL)
Electromagnetic emission	Radiated emissions, test level: 40 dB μ V/m QP with class A, condition of test: 10 m (radio frequency: 30...230 MHz) conforming to EN/IEC 55011 Radiated emissions, test level: 47 dB μ V/m QP with class A, condition of test: 10 m (radio frequency: 230...1000 MHz) conforming to EN/IEC 55011
Ambient air temperature for operation	14...131 °F (-10...55 °C) horizontal installation -10...35 °C vertical installation
Ambient air temperature for storage	-13...158 °F (-25...70 °C)
Relative humidity	10...95 % without condensation in operation 10...95 % without condensation in storage
IP degree of protection	IP20 with protective cover in place
Pollution degree	2
Operating altitude	0...6561.68 ft (0...2000 m)
Storage altitude	0...9842.52 ft (0...3000 m)
Vibration resistance	3.5 mm (vibration frequency: 5...8.4 Hz) on DIN rail 3 gn (vibration frequency: 8.4...150 Hz) on DIN rail 3.5 mm (vibration frequency: 5...8.4 Hz) on panel 3 gn (vibration frequency: 8.4...150 Hz) on panel
Shock resistance	15 gn (test wave duration:11 ms)

Ordering and shipping details

Category	22533 - M2XX PLC & ACCESSORIES
Discount Schedule	MSX
GTIN	00785901981787
Nbr. of units in pkg.	1
Package weight(Lbs)	0.4799999999999998
Returnability	Y
Country of origin	TW

Offer Sustainability

Sustainable offer status	Green Premium product
RoHS (date code: YYWW)	Compliant - since 1348 - Schneider Electric declaration of conformity  Schneider Electric declaration of conformity
REACH	Reference not containing SVHC above the threshold
Product environmental profile	Available
Product end of life instructions	Available
California proposition 65	WARNING: This product can expose you to chemicals including:
- - - - - Substance 1	Lead and lead compounds, which is known to the State of California to cause cancer and birth defects or other reproductive harm.
- - - - - More information	For more information go to www.p65warnings.ca.gov

Dimensions

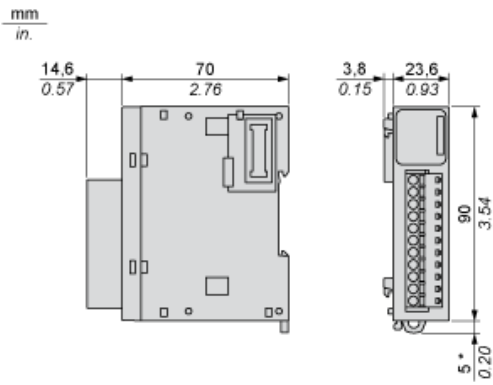

(*) 8.5 mm/0.33 in. when the clamp is pulled out.

Spacing Requirements

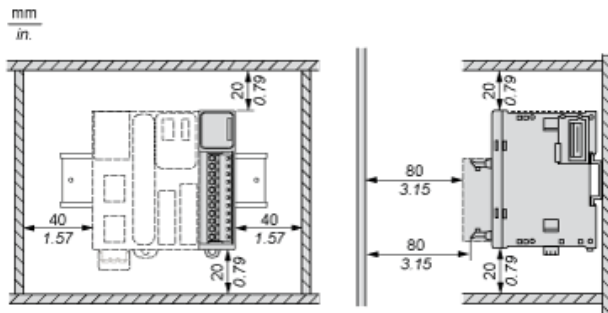

Mounting on a Rail

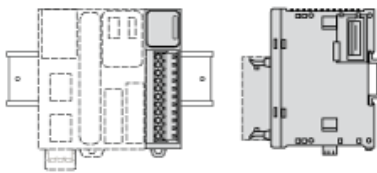

Incorrect Mounting

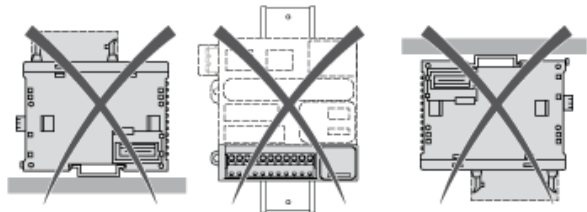

Mounting on a Panel Surface

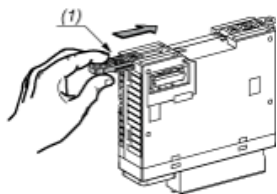

(1) Install a mounting strip

Mounting Hole Layout

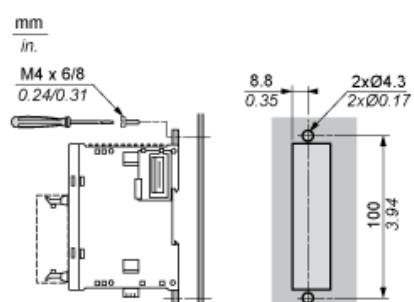

Digital Relay Output Module (8-channel)

Wiring Diagram (Positive Logic)

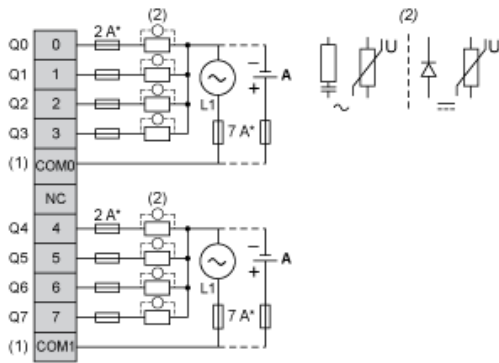

(*) Type T Fuse

(1) The COM0 and COM1 terminals are not connected internally.

(2) To improve the life time of the contacts, and to protect from potential inductive load damage, it is recommended to connect a free wheeling diode in parallel to each inductive DC load or an RC snubber in parallel of each inductive AC load.

(A) Source wiring (positive logic)

Wiring Diagram (Negative Logic)

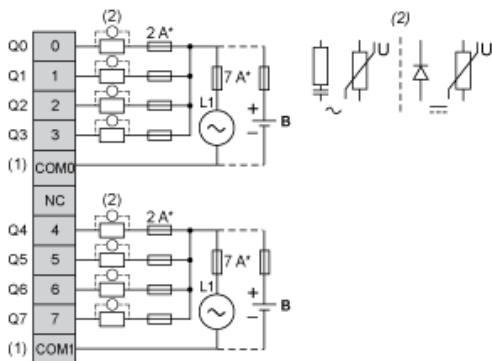

(*) Type T fuse

(1) The COM0 and COM1 terminals are not connected internally.

(2) To improve the life time of the contacts, and to protect from potential inductive load damage, it is recommended to connect a free wheeling diode in parallel to each inductive DC load or an RC snubber in parallel of each inductive AC load.

(B) Sink wiring (negative logic)

Mouser Electronics

Authorized Distributor

Click to View Pricing, Inventory, Delivery & Lifecycle Information:

[Schneider Electric:](#)

[TM3DQ8RG](#)