

Product data sheet

Characteristics

XVUZ400T

Harmony XVU, Fixing metal bracket with 400 mm aluminium pole for modular tower lights, black, Ø60



Product availability: Non-Stock - Not normally stocked in distribution facility

Price*: 32.00 USD



Main

Range of product	Harmony XVU
Product or Component Type	Modular tower light
Accessory / separate part type	Fixing plate
Accessory / separate part category	Mounting and fixing accessory
Component name	XVU
Mounting diameter	2.36 In (60 mm)

Complementary

Pole height	15.75 In (400 mm)
Mounting Support	Metal bracket with pole
Product compatibility	Top AC/DC body
Material	PBT (polybutylene terephthalate) V-0 UL 94 ABS (acrylonitrile butadiene-styrene) PC (polycarbonate) Aluminium
Housing Colour	Black
Connections - Terminals	Push-in
[Us] Rated Supply Voltage	24 V AC/DC 110...240 V AC
Length	17.72 In (450 mm)
Product Weight	0.71 Lb(US) (0.32 kg)

Environment

Ambient Air Temperature for Storage	-40...158 °F (-40...70 °C)
Ambient Air Temperature for Operation	-13...122 °F (-25...50 °C)
IP degree of protection	IP32
Product Certifications	UL CSA CE

Ordering and shipping details

Category	22618 - XVU TOWER LIGHTS
Discount Schedule	XV
GTIN	3606480887147
Nbr. of units in pkg.	1
Package weight(Lbs)	23.60 Oz (669 g)
Returnability	No
Country of origin	ID

Packing Units

Unit Type of Package 1	PCE
Package 1 Height	3.66 In (9.3 cm)
Package 1 width	3.54 In (9 cm)
Package 1 Length	22.32 In (56.7 cm)
Unit Type of Package 2	S04
Number of Units in Package 2	12
Package 2 Weight	20.26 Lb(US) (9.188 kg)
Package 2 Height	11.81 In (30 cm)
Package 2 width	15.75 In (40 cm)
Package 2 Length	23.62 In (60 cm)
Unit Type of Package 3	P06
Number of Units in Package 3	48
Package 3 Weight	88.63 Lb(US) (40.2 kg)
Package 3 Height	23.62 In (60 cm)
Package 3 width	31.50 In (80 cm)
Package 3 Length	23.62 In (60 cm)

Offer Sustainability

Sustainable offer status	Green Premium product
California proposition 65	WARNING: This product can expose you to chemicals including: Lead and lead compounds, which is known to the State of California to cause cancer and birth defects or other reproductive harm. For more information go to www.P65Warnings.ca.gov
REACH Regulation	REACH Declaration
EU RoHS Directive	Pro-active compliance (Product out of EU RoHS legal scope) EU RoHS Declaration
Mercury free	Yes
RoHS exemption information	Yes
China RoHS Regulation	China RoHS Declaration
Environmental Disclosure	Product Environmental Profile
Circularity Profile	End Of Life Information

Fixing Unit - Metal Bracket with Pole

Dimensions with Fixing Unit

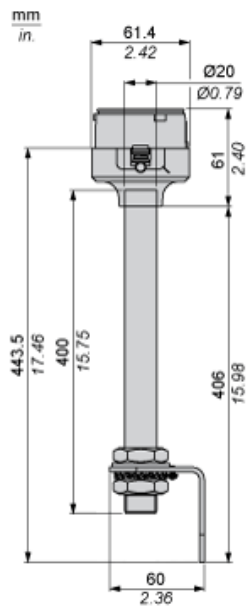

Dimensions for Metal Bracket

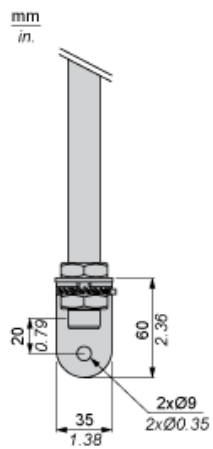

Modular Tower Lights Mounting

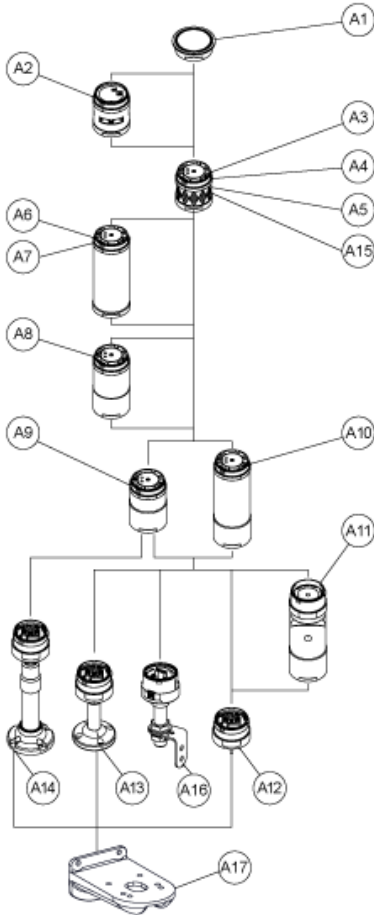

Drawing	Part number	Part name
A1	-	Top cover
-	Top cover (Silver)	
A2	XVUC9S	Buzzer unit
XVUC9SQ	Buzzer unit (Silver)	
A3	XVUC23	Green LED unit
XVUC24	Red LED unit	
XVUC25	Orange LED unit	
XVUC26	Blue LED unit	
XVUC27	White LED unit	
XVUC28	Yellow LED unit	
A4	XVUC29	Multi-LED unit
A5	XVUC29P	Multi-LED unit, Pulse signal
A6	XVUC9V	Sound unit
A7	XVUC9VP	Sound unit, Pulse signal

Drawing	Part number	Part name
A8	XVUC020	Extender
XVUC020Q	Extender (Silver)	
A9	XVUC21B	DC body
XVUC21BQ	DC body (Silver)	
A10	XVUC21M	AC body NPN
XVUC21MP	AC body PNP	
XVUC21MQP	AC body PNP (Silver)	
A11	XVUZ06	Flexible option
A12	XVUZ01	Fixing Unit - Direct mounting (3 pins)
XVUZ01Q	Fixing Unit - Direct mounting (Silver,3 pins)	
XVUZ03	Fixing Unit - Direct mounting (2 pins)	
XVUZ04	Fixing Unit - Direct mounting (4 pins)	
A13	XVUZ02	Fixing Unit - Plate with Pole (100 mm)
XVUZ02Q	Fixing Unit - Plate with Pole (100 mm, Silver)	
XVUZ400	Fixing Unit - Plate with Pole (400 mm)	
XVUZ800	Fixing Unit - Plate with Pole (800 mm)	
A14	XVUZ05	Fixing Unit - Plate with adjustment pole (100-385 mm)
A15	XVUC43	Green LED unit, Flash
XVUC44	Red LED unit, Flash	
XVUC45	Orange LED unit, Flash	
XVUC46	Blue LED unit, Flash	
XVUC47	White LED unit, Flash	
XVUC48	Yellow LED unit, Flash	
A16	XVUZ100T	Fixing Unit - Metal bracket with pole (100 mm)
XVUZ250T	Fixing Unit - Metal bracket with pole(250 mm)	
XVUZ400T	Fixing Unit - Metal bracket with pole (400 mm)	
A17	XVUZ12	Fixing plate for use on vertical support - black

Illuminated Units, Multi-LED and Audible Units Wiring

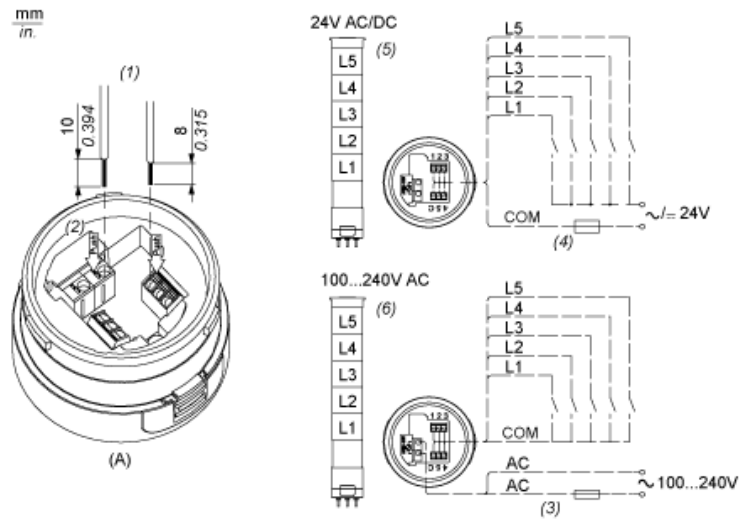

- (A) Fixing Unit
 - (1) Dimensions of Wiring size
 - (2) Push-in Wire Connectors
 - (3) Fuse : 2A ,250V
 - (4) Fuse : 0.5A ,125V
 - (5) Modular Tower Lights 24V AC/DC
 - (6) Modular Tower Lights 100...240V AC
- L1 to L5 Illuminated LED Units

Product Life Status : Commercialised

Mouser Electronics

Authorized Distributor

Click to View Pricing, Inventory, Delivery & Lifecycle Information:

[Schneider Electric:](#)

[XVUZ400T](#)