



Main

Range of product	OsiSense XM
Product or component type	Electronic pressure sensors
Pressure sensor type	Pressure transmitter
Pressure sensor name	XMLP
Electrical circuit type	Control circuit
Pressure rating	25 Bar
Local display	Without
Controlled fluid	Air (-30...135 °C) Fresh water (0...135 °C) Hydraulic oil (-30...135 °C) Gas (-30...135 °C) Refrigeration fluid (-30...135 °C)
Fluid connection type	G 1/4A (male) conforming to DIN 3852-E
Electrical connection	1 male connector EN 175301-803-A (ex DIN43650) 3 pins
[Us] rated supply voltage	12...24 V DC SELV (voltage limits: 7...33 V)
Current consumption	< 23 mA
Type of output signal	Analogue
Analogue output function	4...20 mA, 2-wire
Quantity per set	Set of 1
Type of packing	Individual

Complementary

Pressure setting range	0...25 Bar
Maximum permissible accidental pressure	75 Bar
Destruction pressure	150 Bar
Materials in contact with fluid	Fluorocarbon FPM Stainless steel AISI 316L
Operating position	Any position
Protection type	Load short-circuit Reverse polarity

Electromagnetic compatibility	Electrostatic discharge immunity test conforming to EN/IEC 61000-4-2 8 k-V air, 4 kV contact 1.2/50 µs shock waves immunity test conforming- to EN/IEC 61000-4-5 1 kV 42 Ohm Immunity to magnetic fields conforming to EN/IEC 61000-4-8 100 A/m 50 Hz Electrical fast transient/burst immunity test conforming to EN/IEC 61000-4-4 4 kV Susceptibility to electromagnetic fields conforming- to EN/IEC 61000-4-3 10 V/m 80...3000 MHz Radiated RF fields conforming to EN/IEC 61000-4-6 10 V 0.01...80 MHz
[Uimp] rated impulse withstand voltage	0.5 KV
Response time on output	<= 2 ms 10...90 % of full scale
Measurement accuracy	+/- 0.5 % of the measuring range
Accuracy	0.1 % of the measuring range
Drift of the sensitivity	+/- 0.02 % of measuring range/°K
Drift of the zero point	+/- 0.02 % of measuring range/°K
Mechanical durability	10000000 Cycles
Product weight	0.106 Kg
Diameter	26 Mm
Length	60.6 Mm

Environment

Standards	NSF ANSI 61 EN/IEC 61326-2-3
Product certifications	CE CULus RCM EAC
Protective treatment	TC
Ambient air temperature for operation	-30...85 °C
Ambient air temperature for storage	-50...100 °C
Vibration resistance	20 gn (f = 15...2000 Hz) conforming to EN/IEC 60068-2-6
Shock resistance	100 gn for 11 ms conforming to EN/IEC 60068-2-27
IP degree of protection	IP65 conforming to EN/IEC 60529

Packing Units

Unit Type of Package 1	PCE
Number of Units in Package 1	1
Package 1 Weight	106 G
Package 1 Height	4.3 Cm
Package 1 width	4.7 Cm
Package 1 Length	8.8 Cm
Unit Type of Package 2	S01
Number of Units in Package 2	24
Package 2 Weight	2.769 Kg
Package 2 Height	15 Cm
Package 2 width	15 Cm
Package 2 Length	40 Cm

Offer Sustainability

Sustainable offer status	Green Premium product
REACH Regulation	REACH Declaration
REACH free of SVHC	Yes
EU RoHS Directive	Pro-active compliance (Product out of EU RoHS legal scope) EU RoHS Declaration
Mercury free	Yes
RoHS exemption information	Yes
Environmental Disclosure	Product Environmental Profile

Contractual warranty

Warranty	18 months
----------	-----------

Dimensions

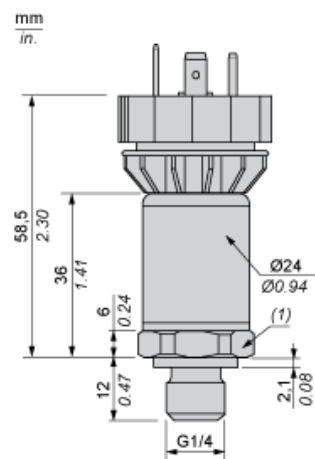

(1) SW24 tightening torque ≤ 25 N.m / 221 lb-in

Wiring Diagram

2-Wire Technique (4-20 mA)

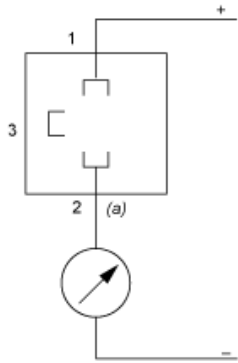

(a) I out

Curves

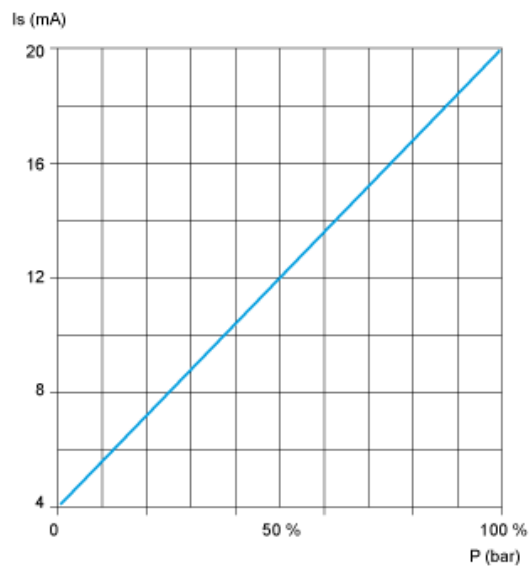

Product Life Status : Commercialised

Mouser Electronics

Authorized Distributor

Click to View Pricing, Inventory, Delivery & Lifecycle Information:

[Schneider Electric:](#)

[XMLP025BC21F](#)