

AC/DC Convertor IC

PWM Type DC/DC Converter IC with Integrated Switching MOSFET

BM2P26CK-Z

General Description

The PWM Type DC/DC converter for AC/DC provides an optimal system for all products that include an electrical outlet.

The built-in 650 V startup circuit contributes to low power consumption. Small-sized power supplies can be designed with a built-in current detection resistor for switching. Current is restricted in each cycle and excellent performance is demonstrated in bandwidth and transient response since current mode control is utilized. The switching frequency is 100 kHz by a fixed method. At light load, the switching frequency is reduced and high efficiency is achieved. A built-in frequency hopping function also contributes to low EMI. A built-in 800 V super junction MOSFET makes designs easy.

Features

- PWM Current Mode Method
- Frequency Hopping Function
- Burst Operation at Light Load
- Frequency Reduction Function
- Built-in 650 V Startup Circuit
- Built-in 800 V Super Junction MOSFET
- VCC UVLO (Under Voltage Lockout)
- VCC OVP (Over Voltage Protection)
- Over Current Detection Function per Cycle
- Over Current Detection AC Voltage Compensation Function
- Soft Start Function
- External Latch Function
- X Capacitor Discharge Function

Key Specifications

- Operating Power Supply Voltage Range
VCC Pin Voltage: 11.9 V to 25.5 V
DRAIN Pin Voltage: 800 V (Max)
VH Pin Voltage: 650 V (Max)
- Current at Switching Operation: 0.6 mA (Typ)
- Current at Burst Operation: 0.35 mA (Typ)
- Switching Frequency: 100 kHz (Typ)
- Operating Temperature Range: -40 °C to +105 °C

Package

DIP7K

W (Typ) x D (Typ) x H (Max)

9.27 mm x 6.35 mm x 8.63 mm
pitch 2.54 mm

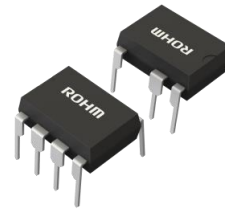

Applications

AC Adapters and Household Appliances

Typical Application Circuit

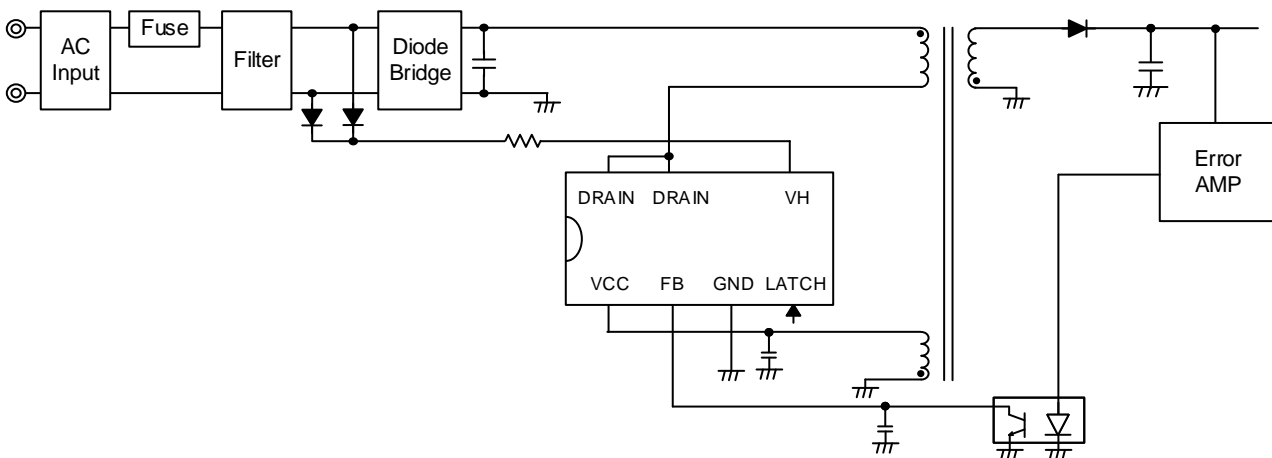

○Product structure : Silicon integrated circuit ○This product has no designed protection against radioactive rays

Pin Configuration

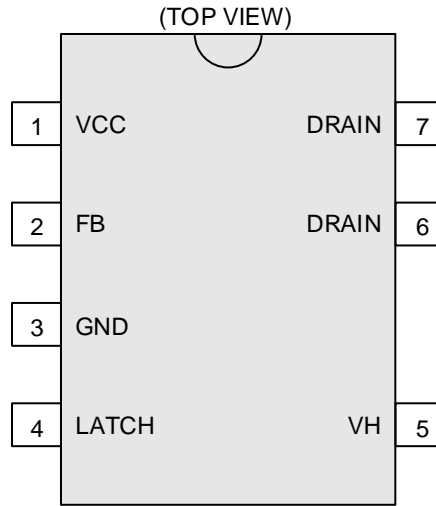

Pin Descriptions

Pin No.	Pin Name	I/O	Function	ESD Diode	
				VCC	GND
1	VCC	I	Power supply input pin		✓
2	FB	I	Feedback signal input pin	-	✓
3	GND	I/O	GND pin	✓	-
4	LATCH	I	External latch pin	-	✓
5	VH	I	AC voltage startup pin	-	✓
6	DRAIN	I/O	MOSFET DRAIN pin	-	✓
7	DRAIN	I/O	MOSFET DRAIN pin	-	✓

Block Diagram

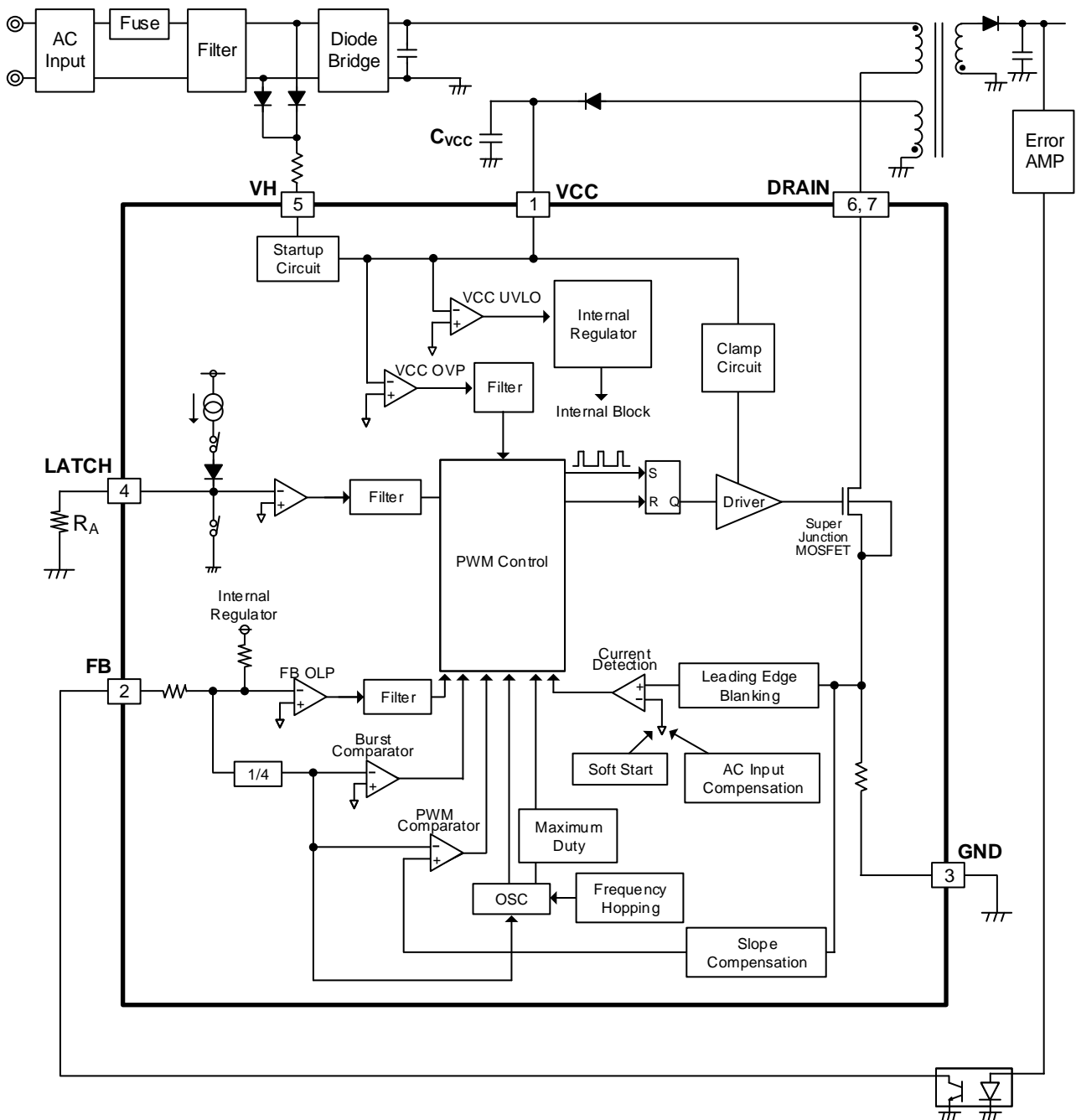

Description of Blocks

1 Startup Circuit

The VH pin controls the following operations.

VH UVLO

(When the AC input voltage becomes less than V_{HUVLO} , it stops the switching operation.)

X Capacitor Discharge Function

(When the AC input voltage is not supplied, it discharges X capacitor.)

It is necessary for the VH pin to be connected from both of the AC lines (L and N) through diodes.

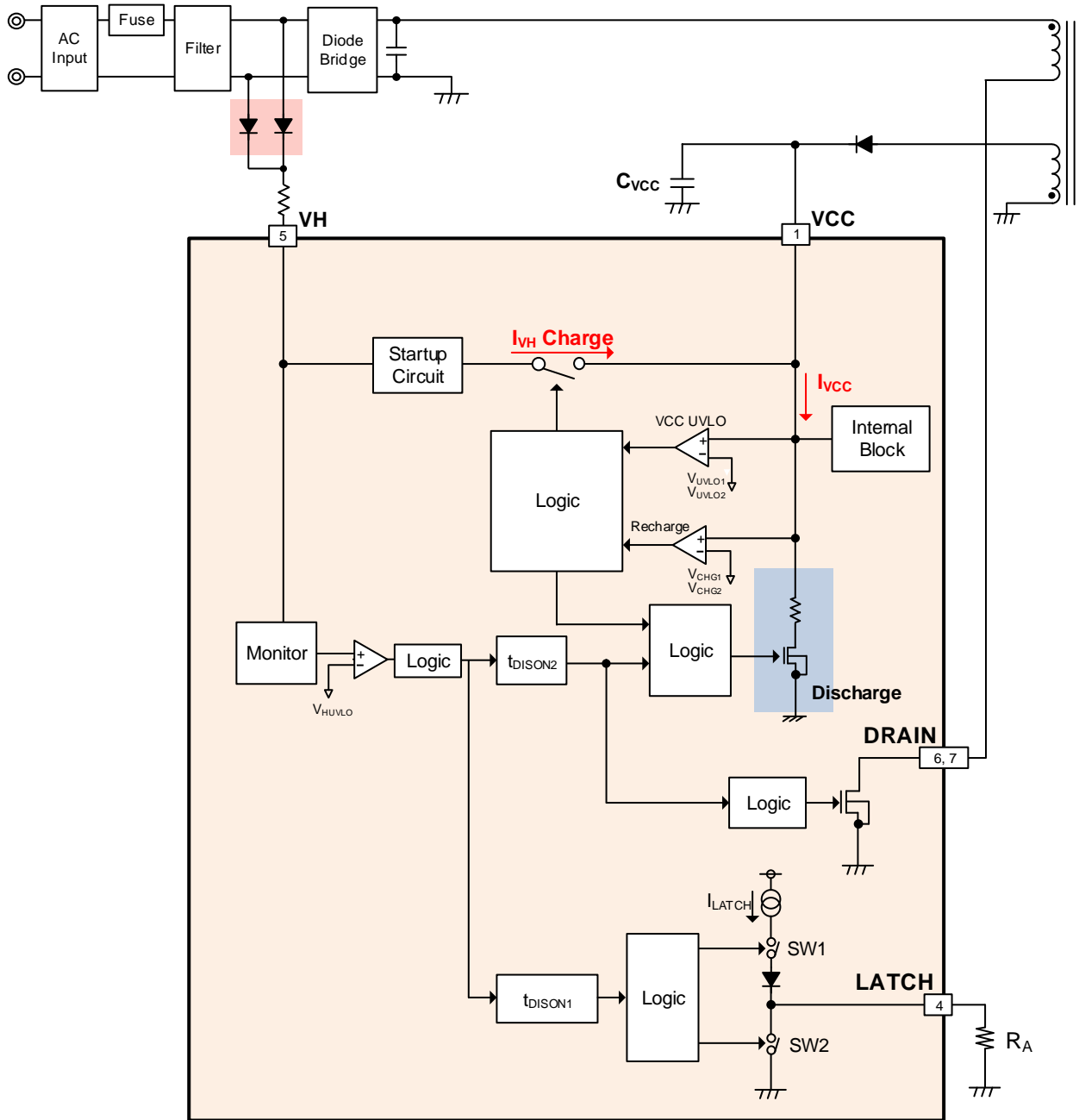

Figure 1. Startup Circuit

1 Startup Circuit – continued

The timing chart of the X capacitor discharge operation is shown below.

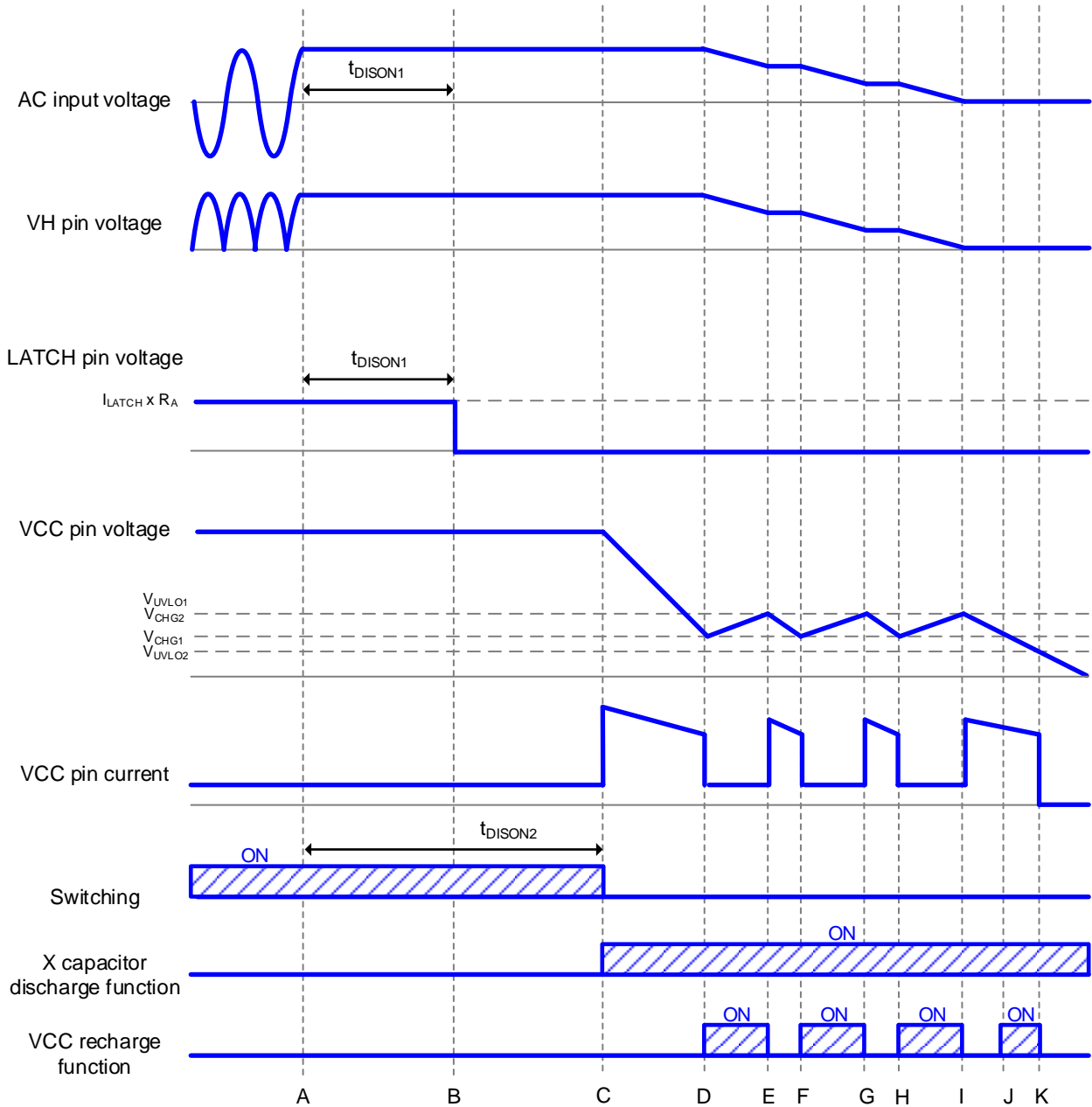

Figure 2. Timing Chart of X Capacitor Discharge Function

- A: The AC input voltage is turned OFF.
- B: After t_{DISON1} from A, the LATCH pin voltage falls.
- C: After t_{DISON2} from A, the switching operation stops and the X capacitor discharge function operates because of the VCC pin voltage $> V_{CHG1}$.
- D: When the VCC pin voltage becomes less than V_{CHG1} , the VCC recharge operation starts.
- E: When the VCC pin voltage becomes more than V_{CHG2} , the VCC recharge operation stops.
- F: Same as D.
- G: Same as E.
- H: Same as D.
- I: Same as E.
- J: When the VCC pin voltage becomes less than V_{CHG1} , the VCC recharge function operates. However, the current supply to the VCC pin decreases and the VCC pin voltage continues to drop because of the low VH pin voltage.
- K: When the VCC pin voltage becomes less than V_{UVLO2} , VCC UVLO operates.

Description of Blocks – continued

2 Startup Sequence

The startup sequence is shown in Figure 3. See the sections below for detailed descriptions.

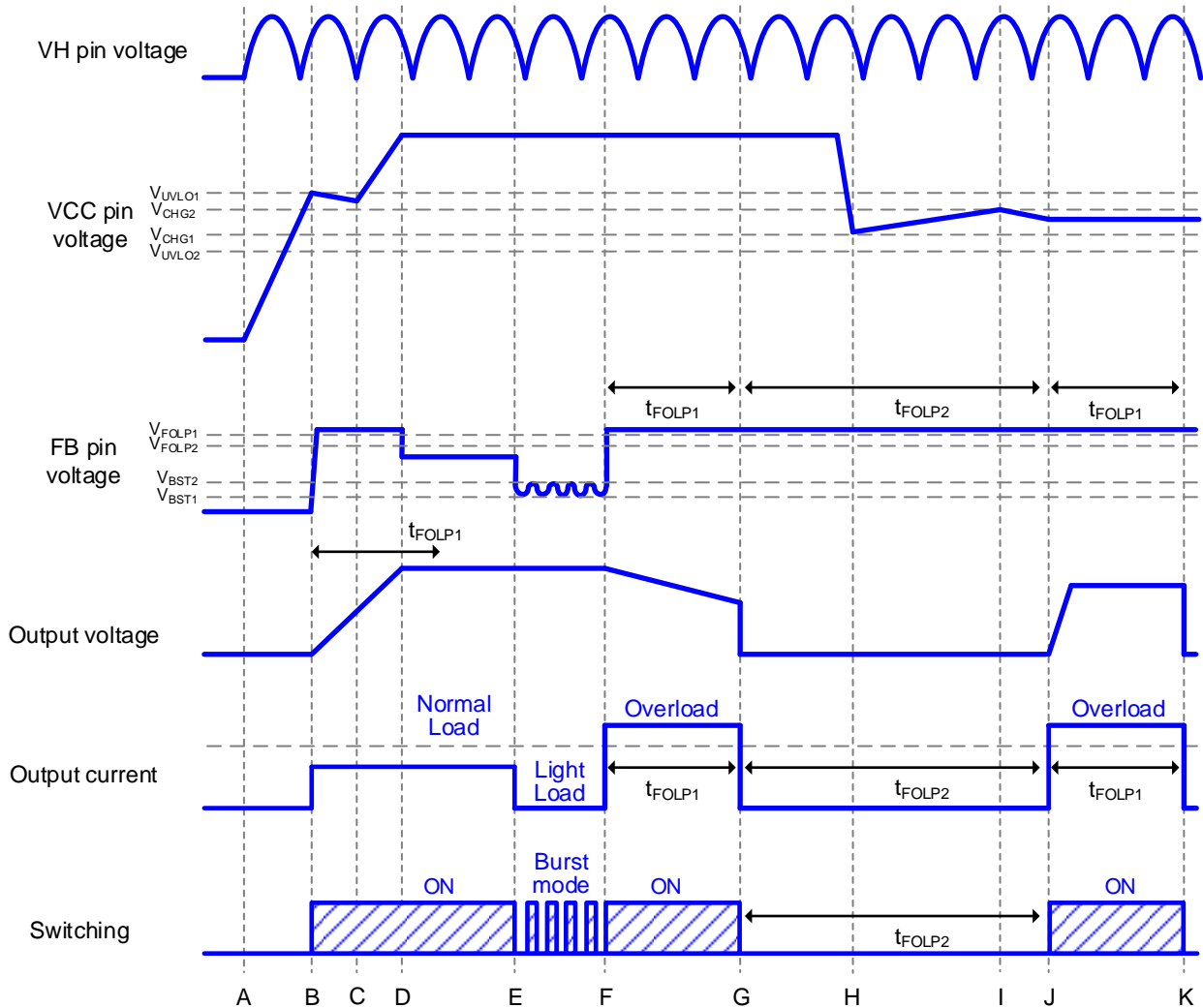

Figure 3. Timing Chart of Startup Sequences

- A: The VH pin voltage is applied and the VCC pin voltage rises.
- B: If the VCC pin voltage becomes more than V_{UVLO1} , the IC starts to operate. And if the IC judges the other protection functions as normal condition, it starts the switching operation. The soft start function limits the over current detection current to prevent any excessive voltage or current rising. When the switching operation starts, the output voltage rises.
- C: Until the output voltage becomes a constant value or more from startup, the VCC pin voltage drops by the VCC pin current consumption.
- D: After the switching operation starts, it is necessary that the output voltage is set to become the rated voltage within t_{FOLP1} .
- E: At light load, the burst operation starts to reduce the power consumption if the FB pin voltage becomes less than V_{BST1} .
- F: When the FB pin voltage becomes more than V_{FOLP1} , the IC starts the overload operation.
- G: When the condition that the FB pin voltage $> V_{FOLP1}$ continues for t_{FOLP1} , the switching stops for t_{FOLP2} period by FB OLP. (If the FB pin voltage becomes less than V_{FOLP2} , FB OLP ON detection timer t_{FOLP1} is reset.)
- H: When the VCC pin voltage becomes less than V_{CHG1} , the VCC recharge function operates.
- I: When the VCC pin voltage becomes more than V_{CHG2} , the VCC recharge function stops operating.
- J: After t_{FOLP2} period from G, the switching operation starts.
- K: Same as G.

Description of Blocks – continued

3 VCC Pin Protection Function

This IC has the internal protection functions at the VCC pin as shown below.

3.1 VCC UVLO

This is an auto recovery comparator with a voltage hysteresis.

3.2 VCC OVP

This is a latch type comparator. VCC OVP has a built-in mask time and it detects when the condition the VCC pin voltage > V_{OVP} continues for t_{LATCH}. Surges occurring at the pin is masks by this function.

3.3 VCC Recharge Function

If the VCC pin voltage drops to less than V_{CHG1} after once the VCC pin becomes more than V_{UVLO1} and the IC starts to operate, the VCC recharge function operates. At this time, the VCC pin is recharged from the VH pin through the startup circuit. When the VCC pin voltage becomes more than V_{CHG2}, this recharge is stopped.

3.4 TSD (Thermal Shutdown)

TSD stops the switching operation if the junction temperature becomes more than T_{SD1}.

4 DC/DC Driver Block

This IC performs a current mode PWM control and it has the following characteristics.

- The switching frequency is fixed at f_{SW1} by an internal oscillator. It has a built-in frequency hopping function and the fluctuation cycle is at random. It makes the EMI low by changing the switching frequency at random. The fluctuation width of frequency is within ±6 % for the fundamental frequency.
- Maximum duty is fixed at D_{MAX}.
- In the current mode control, a sub-harmonic oscillation may occur when the duty cycle exceeds 50 %. As a countermeasure, this IC has a built-in slope compensation circuit.
- It has a built-in burst mode and frequency reduction circuits to achieve lower power consumption at light load.
- The FB pin is pulled up to the internal power supply by R_{FB}.
- The FB pin voltage is changed by the secondary output voltage. This IC monitors the FB pin voltage and changes a switching operation status.

- | | |
|----------------------------------------|--------------------------------------|
| mode 1: Burst Operation | (The intermittent operation starts.) |
| mode 2: Fixed Frequency Operation | (It operates in f _{SW2} .) |
| mode 3: Frequency Modulation Operation | (It modulates the frequency.) |
| mode 4: Fixed Frequency Operation | (It operates in f _{SW1} .) |
| mode 5: Overload Operation | (The intermittent operation starts.) |

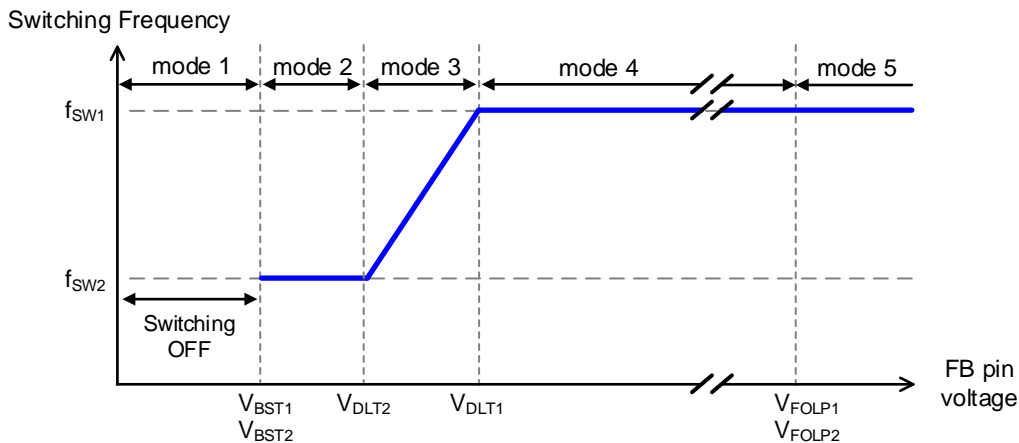

Figure 4. State Transition of Switching Frequency

4 DC/DC Driver Block – continued

4.1 Soft Start Function

At startup, this function controls the over current detection current in order to prevent any excessive voltage or current rising. This IC enables soft start operation by changing the over current detection current with time.

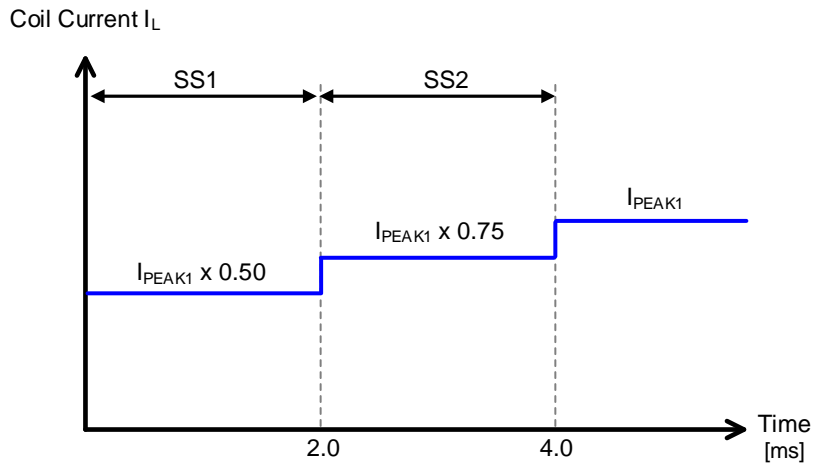

Figure 5. Soft Start Function

4.2 FB OLP (Overload Protection)

FB OLP is the function that monitors the secondary output load status at the FB pin voltage and stops the switching operation at the overload status.

At the overload status, the FB pin voltage rises because current does not flow to the photocoupler because of a drop of the output voltage. When the condition that the FB pin voltage $> V_{FOLP1}$ continues for longer than t_{FOLP1} , it is judged as the overload status and the switching operation stops. If the FB pin voltage falls to less than V_{FOLP2} within t_{FOLP1} from the status that the FB pin voltage $> V_{FOLP1}$, FB OLP ON detection timer is reset.

At startup, the FB pin is pulled up to the IC's internal voltage, so the operation starts from the voltage more than V_{FOLP1} . Therefore, it is necessary to set the startup time within t_{FOLP1} so that the FB pin voltage becomes less than V_{FOLP2} .

Recovery from the detection of overload status is after t_{FOLP2} .

Description of Blocks – continued

5 Over Current Detection Block

5.1 Over Current Detection Function

This IC has a built-in over current detection function per switching cycle. This function stops the switching operation if the coil current I_L becomes I_{PEAK} or more. It also has a built-in AC voltage compensation function. This function makes I_{PEAK} (DC) increase with time.

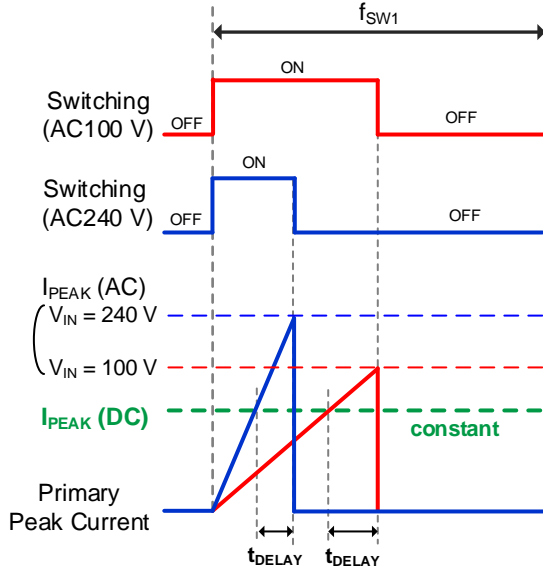

Figure 6. Without the AC Voltage Compensation Function

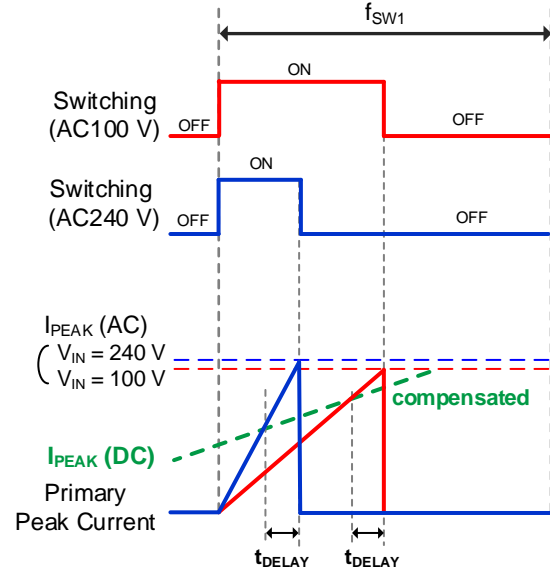

Figure 7. With the AC Voltage Compensation Function

The peak current entering overload mode is calculated using the formula below.

$$Peak\ current = I_{PEAK} + \frac{V_{DC}}{L} \times t_{DELAY} \quad [A]$$

Where:

- I_{PEAK} is the over current detection current.
- V_{DC} is the DC voltage between both ends of coil.
- L is coil value.
- t_{DELAY} is the delay time after the over current detection.

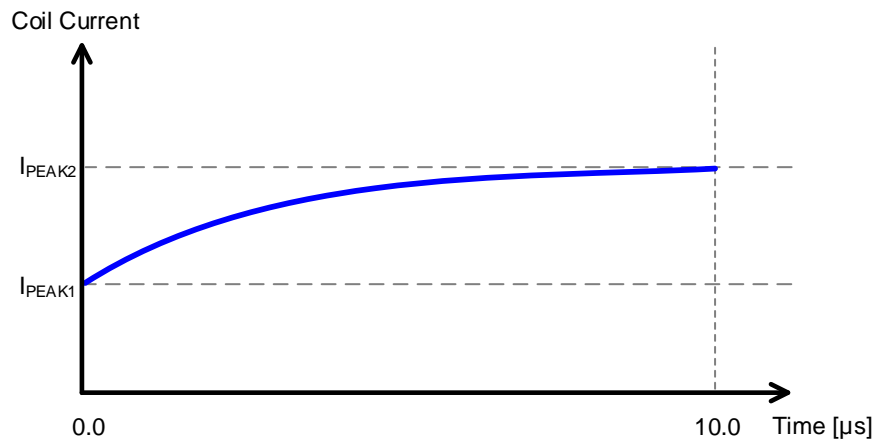

Figure 8. Over Current Detection Voltage

5 Over Current Detection Block – continued

5.2 Dynamic Current Detection Function

This IC has a built-in dynamic over current detection function.

In the case that the coil current I_L exceeds I_{DPEAK} two times consecutively, it stops the switching operation for t_{DPEAK} .

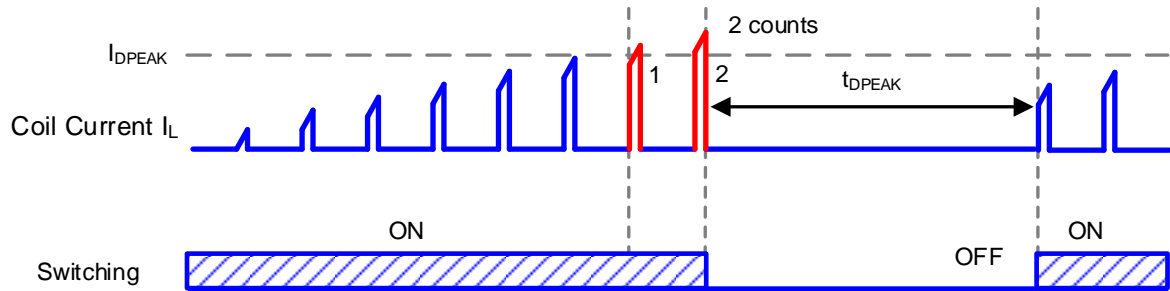

Figure 9. Dynamic Current Detection Function

5.3 Leading Edge Blanking Function

Normally, when the MOSFET for driver is turned ON, surge current is generated at each capacitor component and drive current and so on. At this time, detection errors may occur in the over current detection function because the coil current I_L rises. To prevent these errors, Leading Edge Blanking function is built in this IC. This function masks the coil current I_L for t_{LEB} from the time the DRAIN pin voltage switches H to L.

Description of Blocks – continued

6 LATCH Pin Operation

The LATCH pin has the external latch function and operates as a power supply source for LED.

6.1 Transition of Status by AC Input Voltage

The AC input voltage is monitored by the VH pin.

The transition of the IC's status depends on whether VH UVLO is detected or not.

Table 1. Transition of Status

VH UVLO	LATCH Pin Status	SW1	SW2
Not detected	Current pull-up (I_{LATCH})	OFF	ON
Detected	Resistor pull-down (R_{LATCH})	ON	OFF

6.1.1 When a LED is Connected to the LATCH Pin

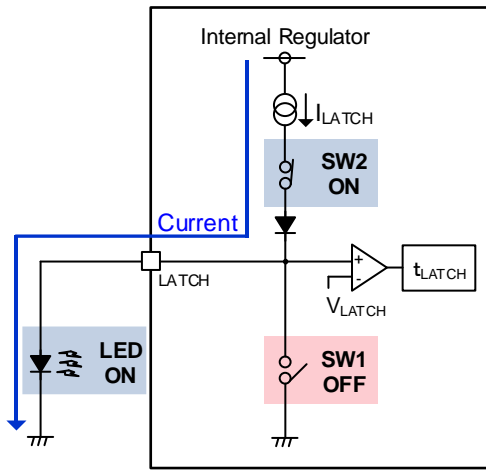

Figure 10. VH UVLO is not Detected

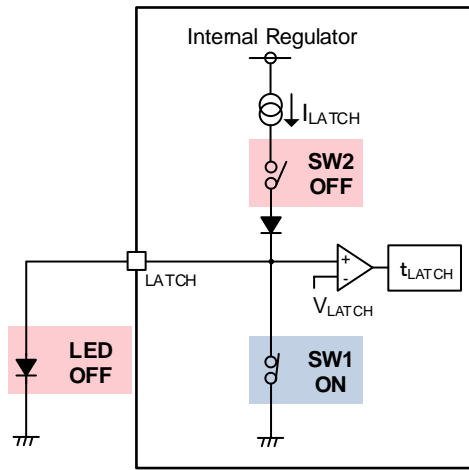

Figure 11. VH UVLO is Detected

6.1.2 When Use the External Latch Function with a Photocoupler

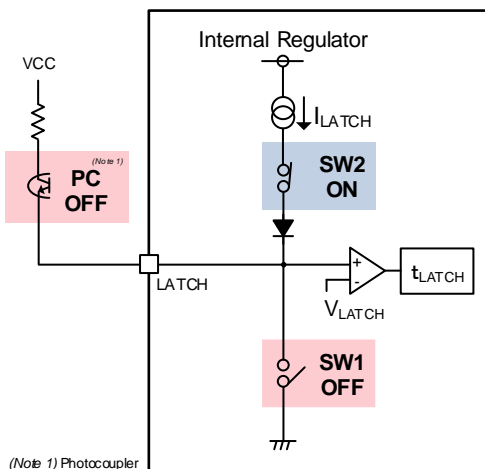

Figure 12. LATCH Pin is not Connected to VCC Pin

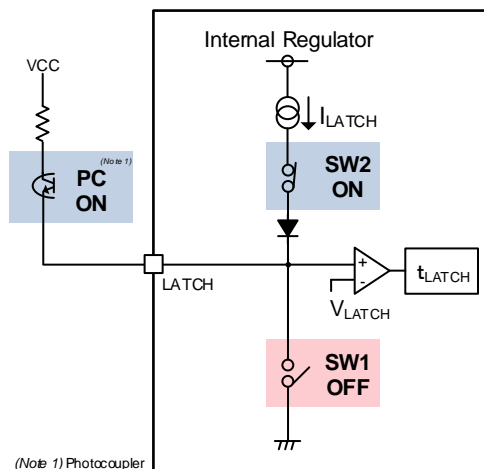

Figure 13. LATCH Pin is Connected to VCC Pin

6 LATCH Pin Operation – continued

6.2 External Latch Function

If the condition of the LATCH pin voltage $> V_{LATCH}$ continues for more than t_{LATCH} , the IC is latched off.

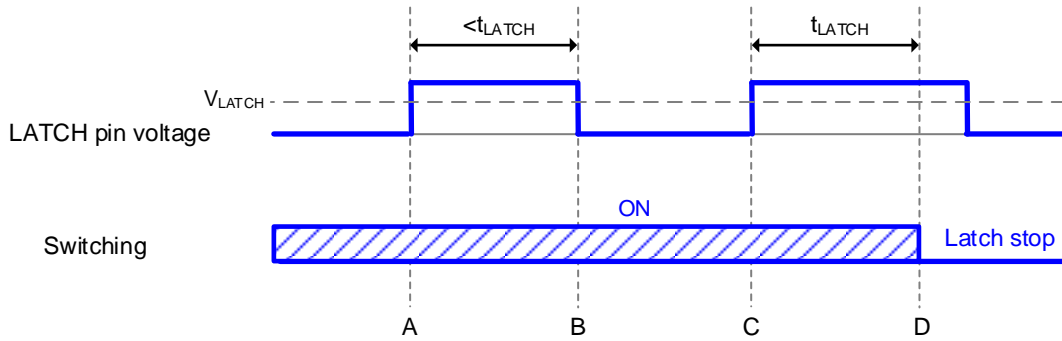

Figure 14. Timing Chart of External Latch Function

- A: The LATCH pin voltage becomes more than V_{LATCH} .
- B: The timer is reset because the LATCH pin voltage becomes V_{LATCH} or less within t_{LATCH} .
- C: The LATCH pin voltage becomes more than V_{LATCH} .
- D: The switching operation is latched off when the condition the LATCH pin voltage $> V_{LATCH}$ continues for more than t_{LATCH} .

Description of Blocks – continued

7 Operation Mode of Protection Functions

The operation modes of each protection function are shown in Table 2.

Table 2. Operation Modes of Protection Functions

	VCC UVLO	VCC OVP	TSD
Detection Conditions	VCC pin voltage < V_{UVLO2} (at voltage falling)	VCC pin voltage > V_{OVP} (at voltage rising)	Junction Temperature > T_{SD1} (at temperature rising)
Release Conditions	VCC pin voltage > V_{UVLO1} (at voltage rising)	VCC pin voltage < V_{RESET} (at voltage falling)	Junction Temperature < T_{SD2} (at temperature falling) or VCC UVLO detection
Detection Timer (Reset Conditions)	–	t_{LATCH} (VCC pin voltage < V_{RESET})	t_{LATCH} (Junction Temperature < T_{SD2})
Release Timer (Reset Conditions)	–	–	–
Auto Recovery or Latch	Auto Recovery	Latch	Auto Recovery

	FB OLP	VH UVLO	External LATCH
Detection Conditions	FB pin voltage > V_{FOLP1} (at voltage rising)	VH pin voltage < V_{HUVLO}	LATCH pin voltage > V_{LATCH}
Release Conditions	FB pin voltage < V_{FOLP2} (at voltage falling) or VCC UVLO detection	VH pin voltage $\geq V_{HUVLO}$ or VCC UVLO detection	LATCH pin voltage $\leq V_{LATCH}$
Detection Timer (Reset Conditions)	t_{FOLP1} (FB pin voltage < V_{FOLP2})	t_{DISON2} (VH pin voltage $\geq V_{HUVLO}$)	t_{LATCH} (VCC pin voltage < V_{RESET})
Release Timer (Reset Conditions)	t_{FOLP2} (FB pin voltage > V_{FOLP1})	–	–
Auto Recovery or Latch	Auto Recovery	Auto Recovery	Latch

Absolute Maximum Ratings (Ta = 25 °C)

Parameter	Symbol	Rating	Unit	Conditions
Maximum Applied Voltage 1	V _{MAX1}	-0.3 to +650	V	VH pin voltage
Maximum Applied Voltage 2	V _{MAX2}	-0.3 to +800	V	DRAIN pin voltage
Maximum Applied Voltage 3	V _{MAX3}	-0.3 to +6.5	V	FB pin voltage
Maximum Applied Voltage 4	V _{MAX4}	-0.3 to +32	V	VCC pin voltage
Maximum Applied Voltage 5	V _{MAX5}	-0.3 to +32	V	LATCH pin voltage
Drain Current (Pulse)	I _{DD}	3.0	A	P _W = 10 μs, Duty cycle = 1 %
Power Dissipation	P _d	1.00	W	(Note 1)
Maximum Junction Temperature	T _{jmax}	+150	°C	
Storage Temperature Range	T _{stg}	-55 to +150	°C	

Caution 1: Operating the IC over the absolute maximum ratings may damage the IC. The damage can either be a short circuit between pins or an open circuit between pins and the internal circuitry. Therefore, it is important to consider circuit protection measures, such as adding a fuse, in case the IC is operated over the absolute maximum ratings.

Caution 2: Should by any chance the maximum junction temperature rating be exceeded the rise in temperature of the chip may result in deterioration of the properties of the chip. In case of exceeding this absolute maximum rating, design a PCB with power dissipation taken into consideration by increasing board size and copper area so as not to exceed the maximum junction temperature rating.

(Note 1) At mounted on a glass epoxy single layer PCB (74.2 mm x 74.2 mm, 1.6 mm). Derate by 8 mW/°C if the IC is used in the ambient temperature Ta 25 °C or above.

Thermal Dissipation

Make the thermal design so that the IC operates in the following conditions.
(Because the following temperature is guarantee value, it is necessary to consider margin.)

1. The ambient temperature Ta must be 105 °C or less.
2. The IC's loss must be the power dissipation Pd or less.

The thermal abatement characteristic is as follows.
(At mounting on a glass epoxy single layer PCB which size is 74.2 mm x 74.2 mm x 1.6 mm)

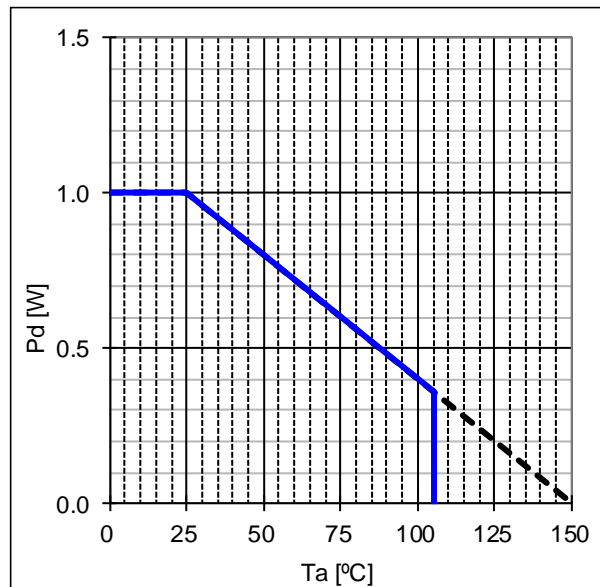

Figure 15. DIP7K Thermal Dissipation Characteristic

Recommended Operating Condition

Parameter	Symbol	Min	Typ	Max	Unit	Conditions
Operating Power Supply Voltage Range 1	V_H	-	-	650	V	VH pin voltage
Operating Power Supply Voltage Range 2	V_{DRAIN}	-	-	800	V	DRAIN pin voltage
Operating Power Supply Voltage Range 3	V_{CC}	11.9	-	25.5	V	VCC pin voltage
Operating Temperature	T_{opr}	-40	-	+105	°C	

Electrical Characteristics in MOSFET Part(Unless otherwise noted, $T_a = 25\text{ °C}$, $V_{CC} = 15\text{ V}$)

Parameter	Symbol	Min	Typ	Max	Unit	Conditions
DRAIN Pin Voltage	$V_{(BR)DS}$	800	-	-	V	$I_D = 1\text{ mA}$, $V_{GS} = 0\text{ V}$
DRAIN Pin Leak Current	I_{DSS}	-	-	100	μA	$V_{DS} = 800\text{ V}$, $V_{GS} = 0\text{ V}$
ON Resistance	$R_{DS(ON)}$	-	6.0	8.4	Ω	$I_D = 0.25\text{ A}$, $V_{GS} = 10\text{ V}$

Electrical Characteristics in Startup Circuit Part(Unless otherwise noted, $T_a = 25\text{ °C}$, $V_{CC} = 15\text{ V}$)

Parameter	Symbol	Min	Typ	Max	Unit	Conditions
Startup Current	I_{START1}	1.50	5.50	10.20	mA	VH pin voltage = 100 V VCC pin voltage = 10 V
VH Pin OFF Current	I_{START2}	5	10	20	μA	VH pin voltage = 100 V
VH UVLO Voltage	V_{HUVLO}	65	80	95	V	
Discharge ON Delay Time 1	t_{DISON1}	102	130	158	ms	
Discharge ON Delay Time 2	t_{DISON2}	204	260	316	ms	

Electrical Characteristics in Control IC Part(Unless otherwise noted, $T_a = 25\text{ °C}$, $V_{CC} = 15\text{ V}$)

Parameter	Symbol	Min	Typ	Max	Unit	Conditions
Circuit Current						
Current at Switching Operation	I_{ON1}	-	0.60	1.20	mA	FB pin voltage = 2.0 V DRAIN pin: open
Current at Burst Operation	I_{ON2}	0.20	0.35	0.50	mA	FB pin voltage = 0.0 V
OFF Current	I_{OFF}	10	20	30	μA	At startup and VCC pin voltage = 14.5 V

Electrical Characteristics in Control IC Part – continued

(Unless otherwise noted, Ta = 25 °C, VCC = 15 V)

Parameter	Symbol	Min	Typ	Max	Unit	Conditions
VCC Pin Protection Function						
VCC UVLO Voltage 1	V _{UVLO1}	14.50	15.50	16.50	V	At VCC pin voltage rising
VCC UVLO Voltage 2	V _{UVLO2}	9.50	10.20	10.90	V	At VCC pin voltage falling
VCC UVLO Hysteresis	V _{UVLO3}	-	5.30	-	V	V _{UVLO3} = V _{UVLO1} - V _{UVLO2}
VCC OVP Voltage	V _{OVP}	26.0	27.5	29.0	V	At VCC pin voltage rising
Latch Released VCC Pin Voltage	V _{RESET}	-	V _{UVLO2} -0.5	-	V	
VCC Recharge Start Voltage	V _{CHG1}	10.20	11.20	12.20	V	
VCC Recharge Stop Voltage	V _{CHG2}	14.00	15.00	16.00	V	
Latch Mask Time	t _{LATCH}	50	100	150	μs	
TSD Temperature 1	T _{SD1}	120	145	170	°C	At temperature rising (Note 1)
TSD Temperature 2	T _{SD2}	90	115	140	°C	At temperature falling (Note 1)
DC/DC Driver Block						
Switching Frequency 1	f _{SW1}	94	100	106	kHz	
Switching Frequency 2	f _{SW2}	30	45	60	kHz	
Frequency Hopping Width	f _{DEL}	-	6.0	-	kHz	
Maximum Duty	D _{MAX}	65	75	85	%	
Frequency Reduction Start FB Pin Voltage	V _{DLT1}	1.14	1.24	1.34	V	
Frequency Reduction End FB Pin Voltage	V _{DLT2}	0.88	0.98	1.08	V	
FB Pin Burst Voltage 1	V _{BST1}	0.70	0.80	0.90	V	At FB pin voltage falling
FB Pin Burst Voltage 2	V _{BST2}	0.76	0.86	0.96	V	At FB pin voltage rising
FB Pin Pull-up Voltage	V _{FB}	3.92	4.00	4.08	V	
FB Pin Pull-up Resistance	R _{FB}	23	30	37	kΩ	
FB OLP Voltage 1	V _{FOLP1}	2.50	2.80	3.10	V	At FB pin voltage rising
FB OLP Voltage 2	V _{FOLP2}	2.30	2.60	2.90	V	At FB pin voltage falling
FB OLP ON Detection Timer	t _{FOLP1}	40	64	88	ms	
FB OLP OFF Timer	t _{FOLP2}	332	512	692	ms	
Over Current Detection Block						
Over Current Detection Current 1	I _{PEAK1}	0.110	0.130	0.150	A	t _{ON} = 0 μs
Over Current Detection Current 2	I _{PEAK2}	0.192	0.240	0.288	A	t _{ON} = 10 μs
Over Current Detection Delay Time	t _{PEAK}	-	300	-	ns	(Note 1)
Dynamic Over Current Detection Current	I _{DPEAK}	-	I _{PEAK1} × 2	-	A	
Dynamic Over Current Detection Time	t _{DPEAK}	70	128	160	μs	
Leading Edge Blanking Time	t _{LEB}	-	300	-	ns	(Note 1)
External Latch Function Block						
External Latch Detection Voltage	V _{LATCH}	7.80	8.50	9.20	V	
LATCH Pin Pull-up Current	I _{LATCH}	250	320	390	μA	
LATCH Pin Pull-down Resistance	R _{LATCH}	120	215	300	Ω	

(Note 1) Not 100 % tested.

Typical Performance Curves

(Reference Data)

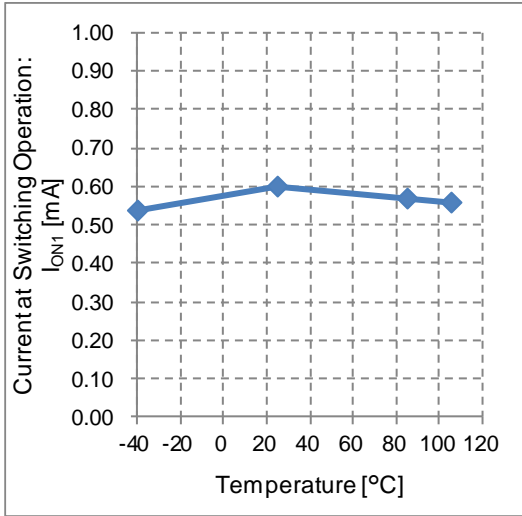

Figure 16. Current at Switching Operation vs Temperature

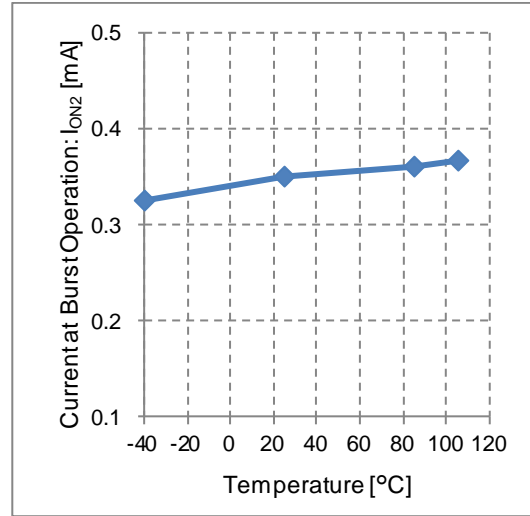

Figure 17. Current at Burst Operation vs Temperature

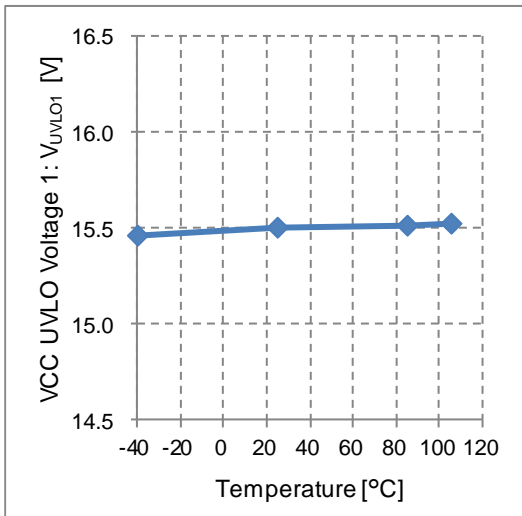

Figure 18. VCC UVLO Voltage 1 vs Temperature

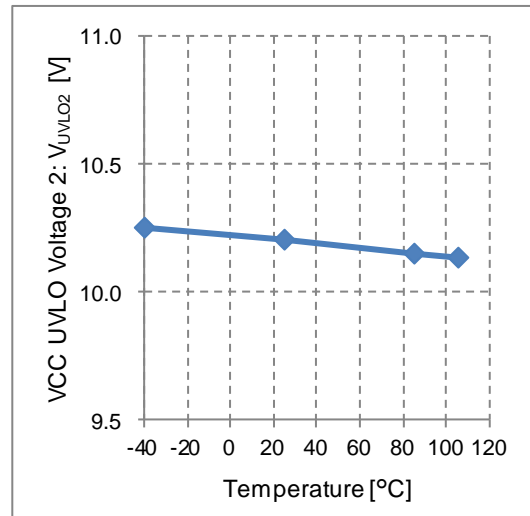

Figure 19. VCC UVLO Voltage 2 vs Temperature

Typical Performance Curves – continued
(Reference Data)

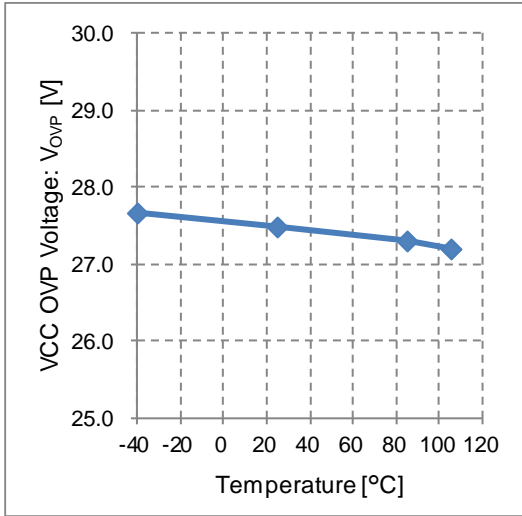

Figure 20. VCC OVP Voltage vs Temperature

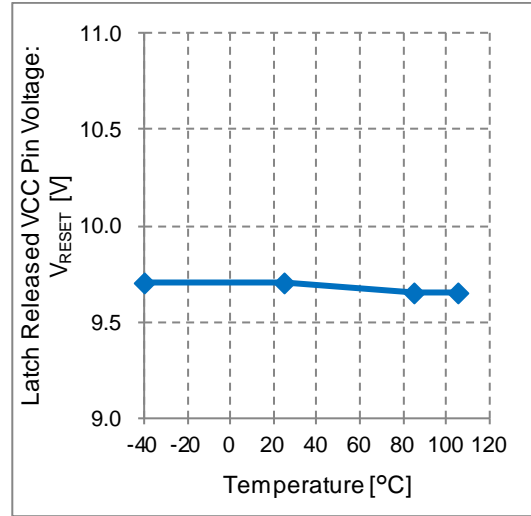

Figure 21. Latch Released VCC Pin Voltage vs Temperature

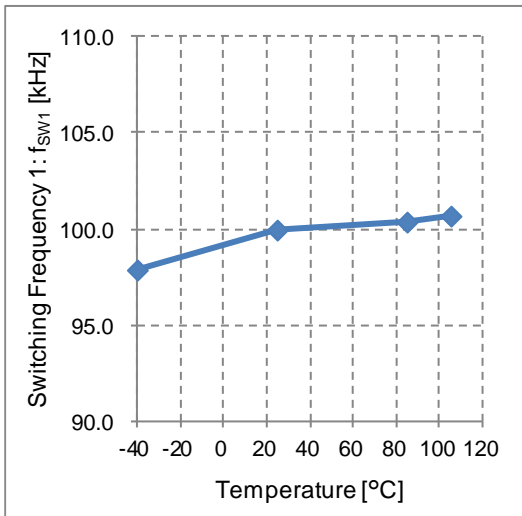

Figure 22. Switching Frequency 1 vs Temperature

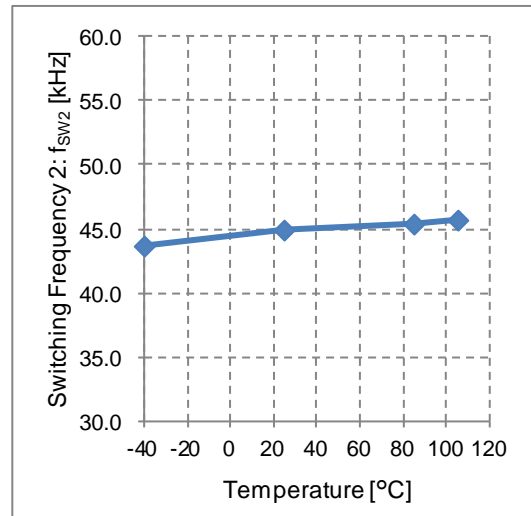

Figure 23. Switching Frequency 2 vs Temperature

Typical Performance Curves – continued
(Reference Data)

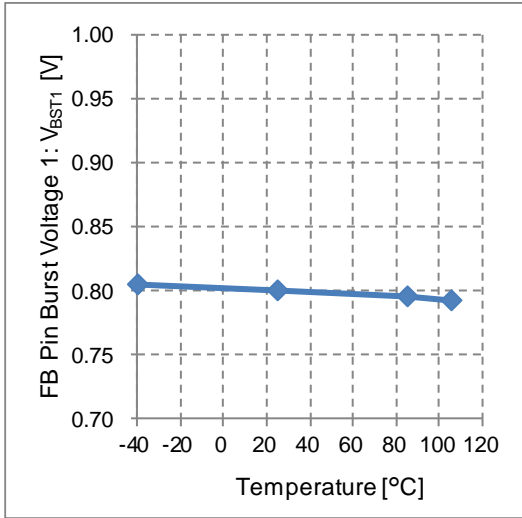

Figure 24. FB Pin Burst Voltage 1 vs Temperature

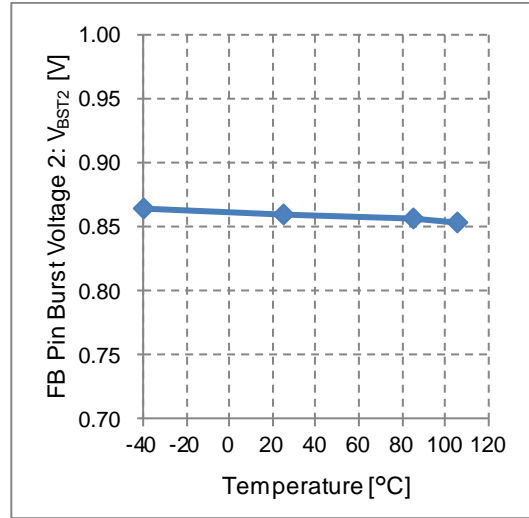

Figure 25. FB Pin Burst Voltage 2 vs Temperature

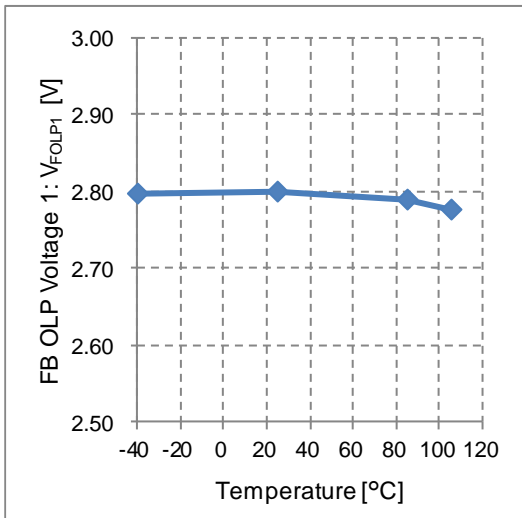

Figure 26. FB OLP Voltage 1 vs Temperature

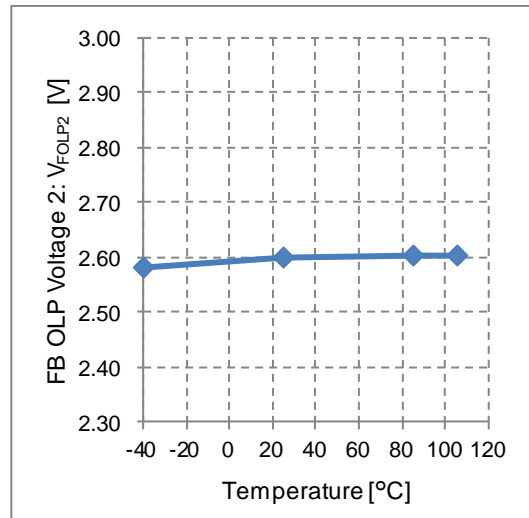

Figure 27. FB OLP Voltage 2 vs Temperature

Typical Performance Curves – continued
(Reference Data)

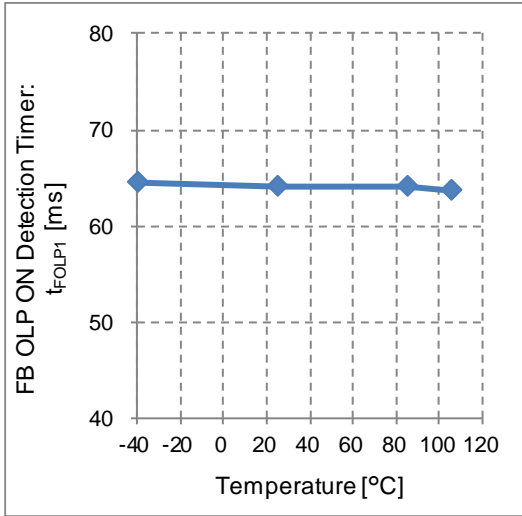

Figure 28. FB OLP ON Detection Timer vs Temperature

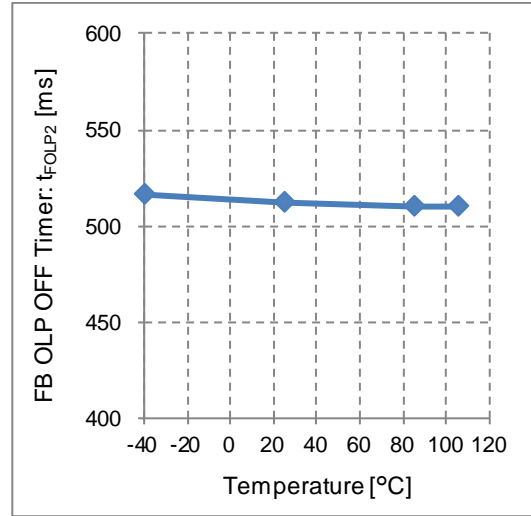

Figure 29. FB OLP OFF Timer vs Temperature

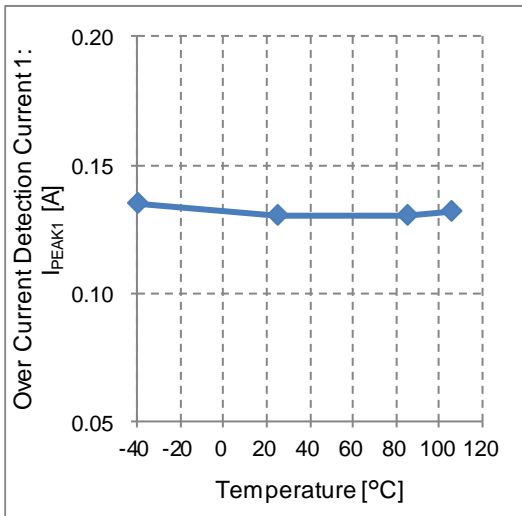

Figure 30. Over Current Detection Current 1 vs Temperature

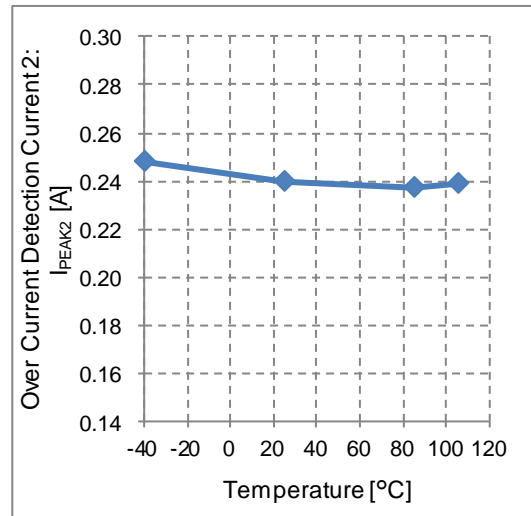

Figure 31. Over Current Detection Current 2 vs Temperature

Typical Performance Curves – continued
(Reference Data)

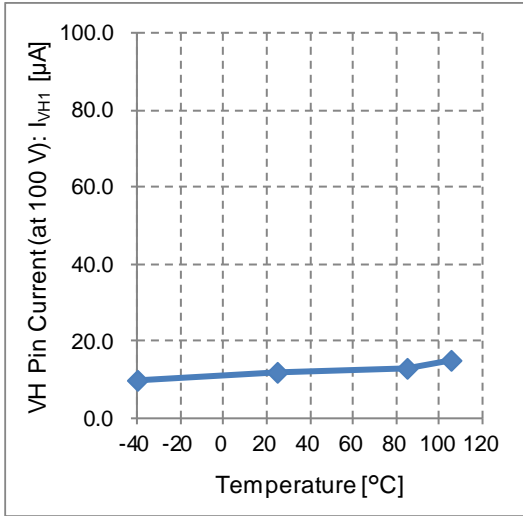

Figure 32. VH Pin Current (at 100 V) vs Temperature

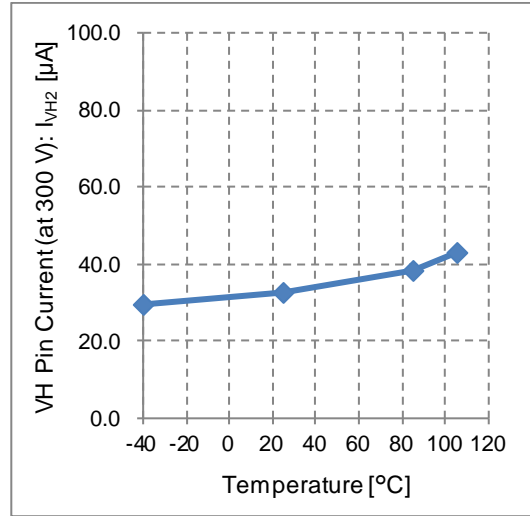

Figure 33. VH Pin Current (at 300V) vs Temperature

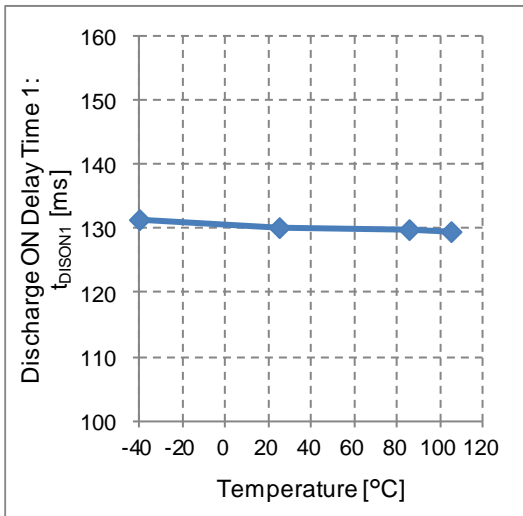

Figure 34. Discharge ON Delay Time 1 vs Temperature

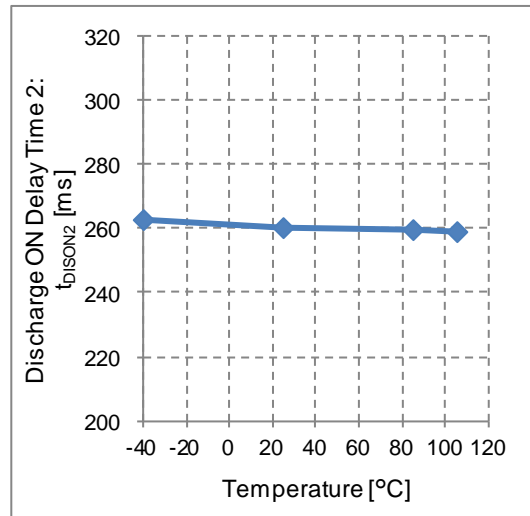

Figure 35. Discharge ON Delay Time 2 vs Temperature

Typical Performance Curves – continued
(Reference Data)

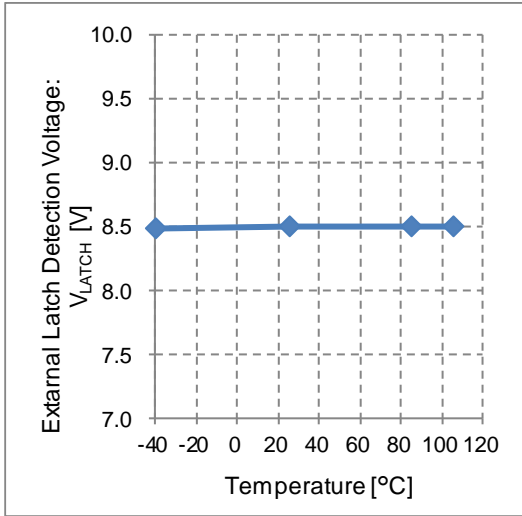

Figure 36. External Latch Detection Voltage vs Temperature

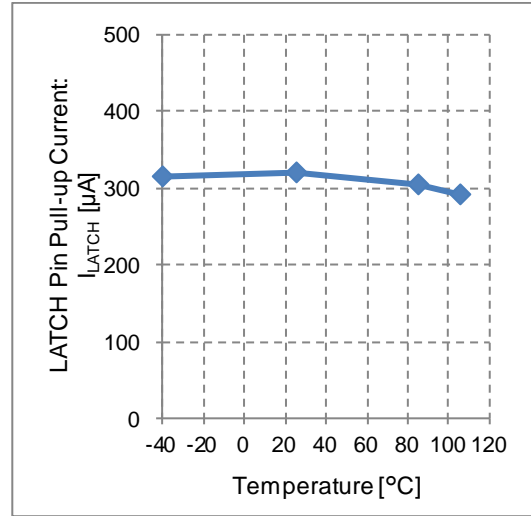

Figure 37. LATCH Pin Pull-up Current vs Temperature

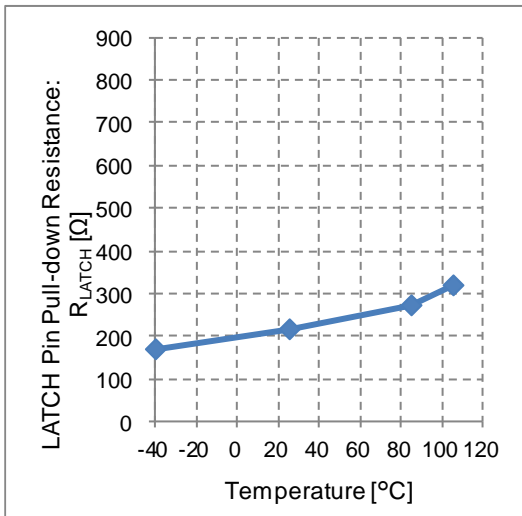
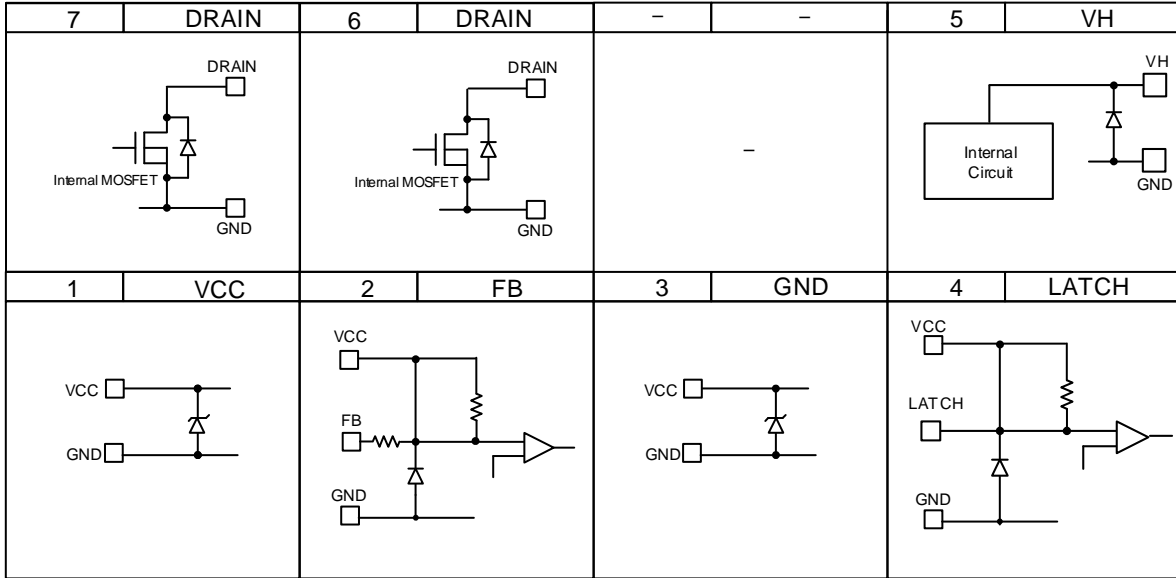

Figure 38. LATCH Pin Pull-down Resistance vs Temperature

I/O Equivalence Circuit



Operational Notes

1. Reverse Connection of Power Supply

Connecting the power supply in reverse polarity can damage the IC. Take precautions against reverse polarity when connecting the power supply, such as mounting an external diode between the power supply and the IC's power supply pins.

2. Power Supply Lines

Design the PCB layout pattern to provide low impedance supply lines. Furthermore, connect a capacitor to ground at all power supply pins. Consider the effect of temperature and aging on the capacitance value when using electrolytic capacitors.

3. Ground Voltage

Ensure that no pins are at a voltage below that of the ground pin at any time, even during transient condition.

4. Ground Wiring Pattern

When using both small-signal and large-current ground traces, the two ground traces should be routed separately but connected to a single ground at the reference point of the application board to avoid fluctuations in the small-signal ground caused by large currents. Also ensure that the ground traces of external components do not cause variations on the ground voltage. The ground lines must be as short and thick as possible to reduce line impedance.

5. Recommended Operating Conditions

The function and operation of the IC are guaranteed within the range specified by the recommended operating conditions. The characteristic values are guaranteed only under the conditions of each item specified by the electrical characteristics.

6. Inrush Current

When power is first supplied to the IC, it is possible that the internal logic may be unstable and inrush current may flow instantaneously due to the internal powering sequence and delays, especially if the IC has more than one power supply. Therefore, give special consideration to power coupling capacitance, power wiring, width of ground wiring, and routing of connections.

7. Testing on Application Boards

When testing the IC on an application board, connecting a capacitor directly to a low-impedance output pin may subject the IC to stress. Always discharge capacitors completely after each process or step. The IC's power supply should always be turned off completely before connecting or removing it from the test setup during the inspection process. To prevent damage from static discharge, ground the IC during assembly and use similar precautions during transport and storage.

8. Inter-pin Short and Mounting Errors

Ensure that the direction and position are correct when mounting the IC on the PCB. Incorrect mounting may result in damaging the IC. Avoid nearby pins being shorted to each other especially to ground, power supply and output pin. Inter-pin shorts could be due to many reasons such as metal particles, water droplets (in very humid environment) and unintentional solder bridge deposited in between pins during assembly to name a few.

9. Unused Input Pins

Input pins of an IC are often connected to the gate of a MOS transistor. The gate has extremely high impedance and extremely low capacitance. If left unconnected, the electric field from the outside can easily charge it. The small charge acquired in this way is enough to produce a significant effect on the conduction through the transistor and cause unexpected operation of the IC. So unless otherwise specified, unused input pins should be connected to the power supply or ground line.

Operational Notes – continued

10. Regarding the Input Pin of the IC

This IC contains P+ isolation and P substrate layers between adjacent elements in order to keep them isolated. P-N junctions are formed at the intersection of the P layers with the N layers of other elements, creating a parasitic diode or transistor. For example (refer to figure below):

When GND > Pin A and GND > Pin B, the P-N junction operates as a parasitic diode.
 When GND > Pin B, the P-N junction operates as a parasitic transistor.

Parasitic diodes inevitably occur in the structure of the IC. The operation of parasitic diodes can result in mutual interference among circuits, operational faults, or physical damage. Therefore, conditions that cause these diodes to operate, such as applying a voltage lower than the GND voltage to an input pin (and thus to the P substrate) should be avoided.

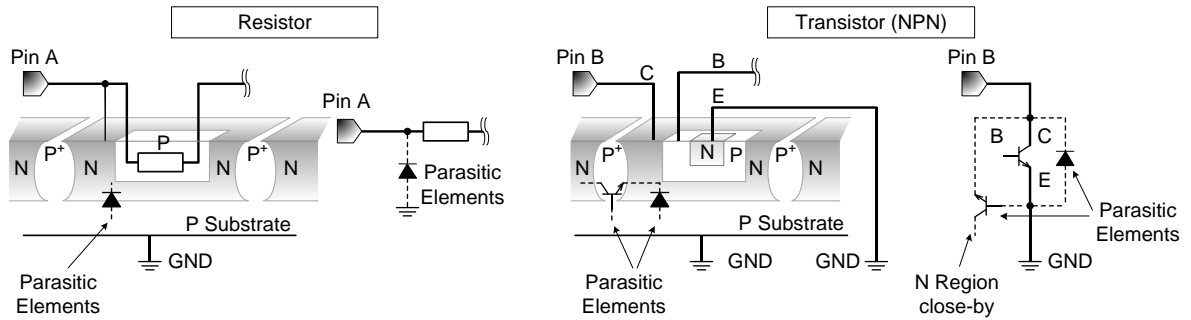

Figure 39. Example of IC Structure

11. Ceramic Capacitor

When using a ceramic capacitor, determine a capacitance value considering the change of capacitance with temperature and the decrease in nominal capacitance due to DC bias and others.

12. Thermal Shutdown Circuit (TSD)

This IC has a built-in thermal shutdown circuit that prevents heat damage to the IC. Normal operation should always be within the IC's maximum junction temperature rating. If however the rating is exceeded for a continued period, the junction temperature (T_j) will rise which will activate the TSD circuit that will turn OFF power output pins. When the T_j falls below the TSD threshold, the circuits are automatically restored to normal operation.

Note that the TSD circuit operates in a situation that exceeds the absolute maximum ratings and therefore, under no circumstances, should the TSD circuit be used in a set design or for any purpose other than protecting the IC from heat damage.

13. Over Current Protection Circuit (OCP)

This IC incorporates an integrated overcurrent protection circuit that is activated when the load is shorted. This protection circuit is effective in preventing damage due to sudden and unexpected incidents. However, the IC should not be used in applications characterized by continuous operation or transitioning of the protection circuit.

Ordering Information

B M 2 P 2 6 C K - Z

Marking Diagram

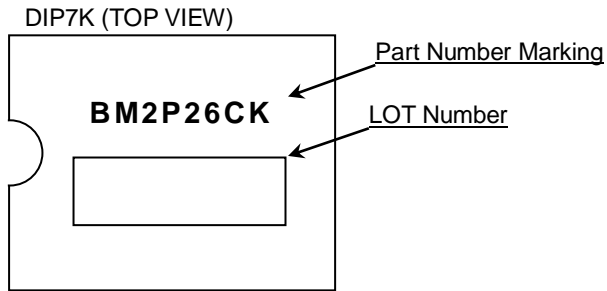

Physical Dimension and Packing Information

Package Name	DIP7K
--------------	-------

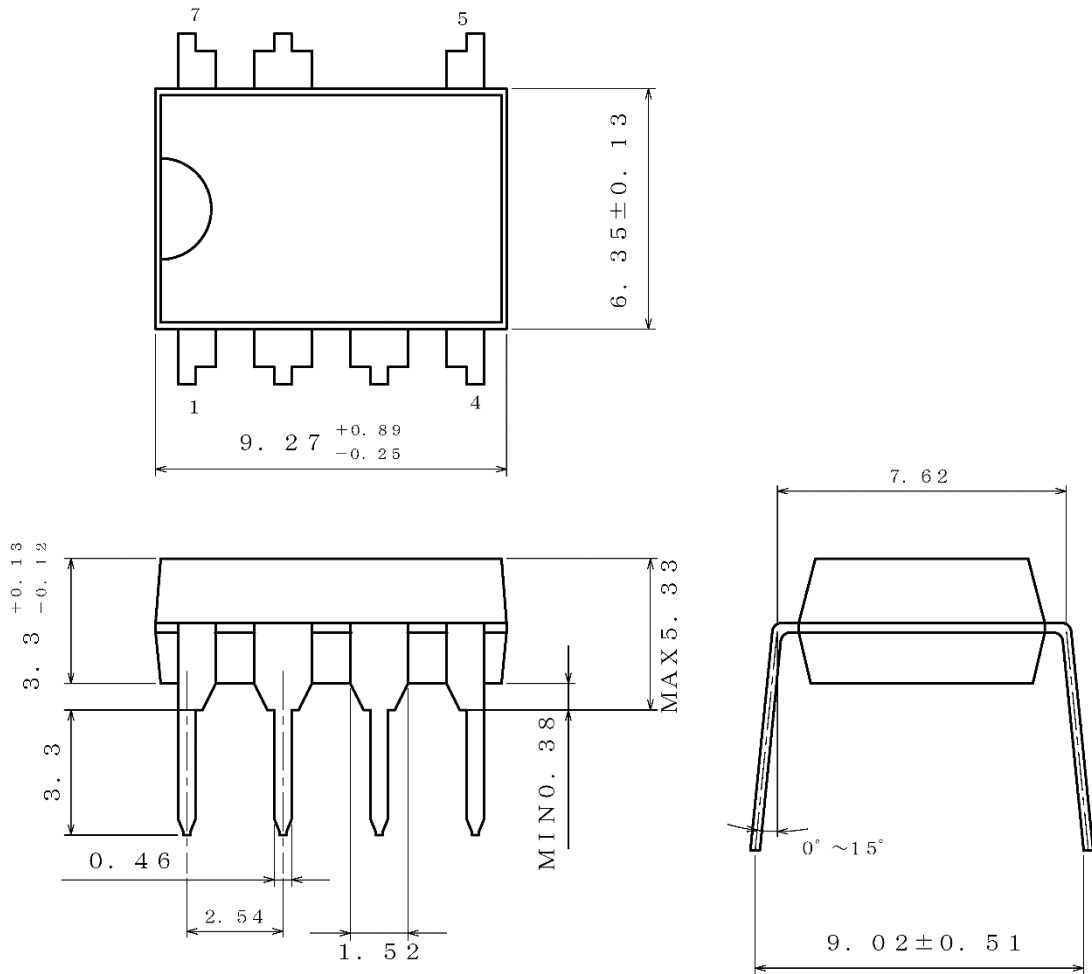

(UNIT : mm)
 PKG : DIP7K
 Drawing No. EX001-0076

< Container Information >

Container	Tube
Quantity	2000pcs
Direction of feed	Packing orientation is same in tube

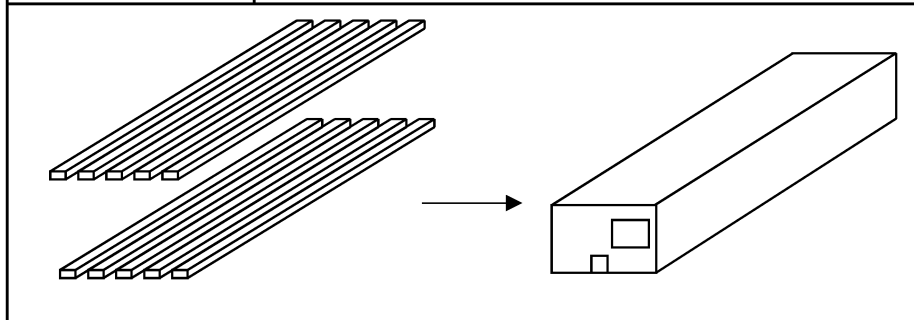

Revision History

Date	Rev.	Changes
11.Jul.2019	001	New Release

Notice

Precaution on using ROHM Products

- Our Products are designed and manufactured for application in ordinary electronic equipment (such as AV equipment, OA equipment, telecommunication equipment, home electronic appliances, amusement equipment, etc.). If you intend to use our Products in devices requiring extremely high reliability (such as medical equipment ^(Note 1), transport equipment, traffic equipment, aircraft/spacecraft, nuclear power controllers, fuel controllers, car equipment including car accessories, safety devices, etc.) and whose malfunction or failure may cause loss of human life, bodily injury or serious damage to property ("Specific Applications"), please consult with the ROHM sales representative in advance. Unless otherwise agreed in writing by ROHM in advance, ROHM shall not be in any way responsible or liable for any damages, expenses or losses incurred by you or third parties arising from the use of any ROHM's Products for Specific Applications.

(Note1) Medical Equipment Classification of the Specific Applications

JAPAN	USA	EU	CHINA
CLASS III	CLASS III	CLASS II b	CLASS III
CLASS IV		CLASS III	

- ROHM designs and manufactures its Products subject to strict quality control system. However, semiconductor products can fail or malfunction at a certain rate. Please be sure to implement, at your own responsibilities, adequate safety measures including but not limited to fail-safe design against the physical injury, damage to any property, which a failure or malfunction of our Products may cause. The following are examples of safety measures:
 - Installation of protection circuits or other protective devices to improve system safety
 - Installation of redundant circuits to reduce the impact of single or multiple circuit failure
- Our Products are designed and manufactured for use under standard conditions and not under any special or extraordinary environments or conditions, as exemplified below. Accordingly, ROHM shall not be in any way responsible or liable for any damages, expenses or losses arising from the use of any ROHM's Products under any special or extraordinary environments or conditions. If you intend to use our Products under any special or extraordinary environments or conditions (as exemplified below), your independent verification and confirmation of product performance, reliability, etc. prior to use, must be necessary:
 - Use of our Products in any types of liquid, including water, oils, chemicals, and organic solvents
 - Use of our Products outdoors or in places where the Products are exposed to direct sunlight or dust
 - Use of our Products in places where the Products are exposed to sea wind or corrosive gases, including Cl₂, H₂S, NH₃, SO₂, and NO₂
 - Use of our Products in places where the Products are exposed to static electricity or electromagnetic waves
 - Use of our Products in proximity to heat-producing components, plastic cords, or other flammable items
 - Sealing or coating our Products with resin or other coating materials
 - Use of our Products without cleaning residue of flux (Exclude cases where no-clean type fluxes is used. However, recommend sufficiently about the residue.) ; or Washing our Products by using water or water-soluble cleaning agents for cleaning residue after soldering
 - Use of the Products in places subject to dew condensation
- The Products are not subject to radiation-proof design.
- Please verify and confirm characteristics of the final or mounted products in using the Products.
- In particular, if a transient load (a large amount of load applied in a short period of time, such as pulse, is applied, confirmation of performance characteristics after on-board mounting is strongly recommended. Avoid applying power exceeding normal rated power; exceeding the power rating under steady-state loading condition may negatively affect product performance and reliability.
- De-rate Power Dissipation depending on ambient temperature. When used in sealed area, confirm that it is the use in the range that does not exceed the maximum junction temperature.
- Confirm that operation temperature is within the specified range described in the product specification.
- ROHM shall not be in any way responsible or liable for failure induced under deviant condition from what is defined in this document.

Precaution for Mounting / Circuit board design

- When a highly active halogenous (chlorine, bromine, etc.) flux is used, the residue of flux may negatively affect product performance and reliability.
- In principle, the reflow soldering method must be used on a surface-mount products, the flow soldering method must be used on a through hole mount products. If the flow soldering method is preferred on a surface-mount products, please consult with the ROHM representative in advance.

For details, please refer to ROHM Mounting specification

Precautions Regarding Application Examples and External Circuits

1. If change is made to the constant of an external circuit, please allow a sufficient margin considering variations of the characteristics of the Products and external components, including transient characteristics, as well as static characteristics.
2. You agree that application notes, reference designs, and associated data and information contained in this document are presented only as guidance for Products use. Therefore, in case you use such information, you are solely responsible for it and you must exercise your own independent verification and judgment in the use of such information contained in this document. ROHM shall not be in any way responsible or liable for any damages, expenses or losses incurred by you or third parties arising from the use of such information.

Precaution for Electrostatic

This Product is electrostatic sensitive product, which may be damaged due to electrostatic discharge. Please take proper caution in your manufacturing process and storage so that voltage exceeding the Products maximum rating will not be applied to Products. Please take special care under dry condition (e.g. Grounding of human body / equipment / solder iron, isolation from charged objects, setting of Ionizer, friction prevention and temperature / humidity control).

Precaution for Storage / Transportation

1. Product performance and soldered connections may deteriorate if the Products are stored in the places where:
 - [a] the Products are exposed to sea winds or corrosive gases, including Cl₂, H₂S, NH₃, SO₂, and NO₂
 - [b] the temperature or humidity exceeds those recommended by ROHM
 - [c] the Products are exposed to direct sunshine or condensation
 - [d] the Products are exposed to high Electrostatic
2. Even under ROHM recommended storage condition, solderability of products out of recommended storage time period may be degraded. It is strongly recommended to confirm solderability before using Products of which storage time is exceeding the recommended storage time period.
3. Store / transport cartons in the correct direction, which is indicated on a carton with a symbol. Otherwise bent leads may occur due to excessive stress applied when dropping of a carton.
4. Use Products within the specified time after opening a humidity barrier bag. Baking is required before using Products of which storage time is exceeding the recommended storage time period.

Precaution for Product Label

A two-dimensional barcode printed on ROHM Products label is for ROHM's internal use only.

Precaution for Disposition

When disposing Products please dispose them properly using an authorized industry waste company.

Precaution for Foreign Exchange and Foreign Trade act

Since concerned goods might be fallen under listed items of export control prescribed by Foreign exchange and Foreign trade act, please consult with ROHM in case of export.

Precaution Regarding Intellectual Property Rights

1. All information and data including but not limited to application example contained in this document is for reference only. ROHM does not warrant that foregoing information or data will not infringe any intellectual property rights or any other rights of any third party regarding such information or data.
2. ROHM shall not have any obligations where the claims, actions or demands arising from the combination of the Products with other articles such as components, circuits, systems or external equipment (including software).
3. No license, expressly or implied, is granted hereby under any intellectual property rights or other rights of ROHM or any third parties with respect to the Products or the information contained in this document. Provided, however, that ROHM will not assert its intellectual property rights or other rights against you or your customers to the extent necessary to manufacture or sell products containing the Products, subject to the terms and conditions herein.

Other Precaution

1. This document may not be reprinted or reproduced, in whole or in part, without prior written consent of ROHM.
2. The Products may not be disassembled, converted, modified, reproduced or otherwise changed without prior written consent of ROHM.
3. In no event shall you use in any way whatsoever the Products and the related technical information contained in the Products or this document for any military purposes, including but not limited to, the development of mass-destruction weapons.
4. The proper names of companies or products described in this document are trademarks or registered trademarks of ROHM, its affiliated companies or third parties.

General Precaution

1. Before you use our Products, you are requested to carefully read this document and fully understand its contents. ROHM shall not be in any way responsible or liable for failure, malfunction or accident arising from the use of any ROHM's Products against warning, caution or note contained in this document.
2. All information contained in this document is current as of the issuing date and subject to change without any prior notice. Before purchasing or using ROHM's Products, please confirm the latest information with a ROHM sales representative.
3. The information contained in this document is provided on an "as is" basis and ROHM does not warrant that all information contained in this document is accurate and/or error-free. ROHM shall not be in any way responsible or liable for any damages, expenses or losses incurred by you or third parties resulting from inaccuracy or errors of or concerning such information.

Mouser Electronics

Authorized Distributor

Click to View Pricing, Inventory, Delivery & Lifecycle Information:

[ROHM Semiconductor:](#)

[BM2P26CK-Z](#)