

# RC-1RS1NRAZ700 - 1603297

Please be informed that the data shown in this PDF Document is generated from our Online Catalog. Please find the complete data in the user's documentation. Our General Terms of Use for Downloads are valid (<http://phoenixcontact.com/download>)

Cable connector, with Pg13.5 connection thread, angled, shielded: no, Screw locking, M23, No. of pos.: 16+2+PE, type of contact: Socket, Crimp connection, cable diameter range: 10 mm ... 14 mm



## Key Commercial Data

Packing unit	8 pc
GTIN	 4 046356 244756
GTIN	4046356244756

## Technical data

### Data of the insulating body

Note	Order information: Order crimp contacts 16 x Ø 1 mm, 2 x Ø 1.5 mm, 1 x Ø 1.5 (PE) separately
Coding	N
Contact connection method	Crimp connection
Type of contacts	Socket
Application	Signal
Number of positions	19
Contact diameter of power contacts	1.5 mm
Nominal current per power contact at 25°C	10 A
Nominal voltage, power contact	150 V
Rated surge voltage	1.5 kV
Overvoltage category	II
Degree of pollution	3
Contact diameter of signal contacts	1 mm
Nominal current per signal contact at 25°C	8 A
Nominal voltage, signal contact	150 V
Overvoltage category	II
Degree of pollution	3

### Housing data

Note	Order information: Order contact inserts and cable clamping separately
Housing material	Metal
Type of locking	Screw locking

# RC-1RS1NRAZ700 - 1603297

## Technical data

### Housing data

Degree of protection (when plugged in)	IP65
	IP67
Thread type	M23

### Cable seal data

Cable diameter	10 mm ... 14 mm
----------------	-----------------

### Environmental Product Compliance

REACH SVHC	Lead 7439-92-1
China RoHS	Environmentally Friendly Use Period = 50
	For details about hazardous substances go to tab "Downloads", Category "Manufacturer's declaration"

## Drawings

Schematic diagram

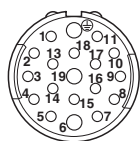

Dimensional drawing

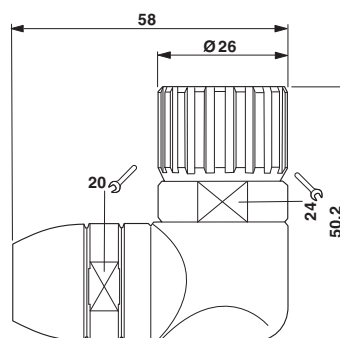

## Approvals

Approvals

Approvals

EAC

Ex Approvals

### Approval details

EAC		B.01742
-----	--	---------

Phoenix Contact 2018 © - all rights reserved  
<http://www.phoenixcontact.com>

PHOENIX CONTACT GmbH & Co. KG  
Flachmarktstr. 8  
32825 Blomberg  
Germany  
Tel. +49 5235 300  
Fax +49 5235 3 41200  
<http://www.phoenixcontact.com>

# Mouser Electronics

Authorized Distributor

Click to View Pricing, Inventory, Delivery & Lifecycle Information:

[Phoenix Contact:](#)

[1603297](#)