

# Cable connector - RC-12S1N8AT006 - 1599319

Please be informed that the data shown in this PDF Document is generated from our Online Catalog. Please find the complete data in the user's documentation. Our General Terms of Use for Downloads are valid (<http://phoenixcontact.com/download>)

Cable connector, angled, shielded: yes, Screw locking, M23, No. of pos.: 12, type of contact: Socket, Crimp connection, cable diameter range: 7.5 mm ... 9.5 mm



## Key Commercial Data

Packing unit	8 pc
GTIN	 4 046356 225281
GTIN	4046356225281

## Technical data

### Environmental Product Compliance

REACH SVHC	Lead 7439-92-1
China RoHS	Environmentally Friendly Use Period = 50
	For details about hazardous substances go to tab "Downloads", Category "Manufacturer's declaration"

## Drawings

Schematic diagram

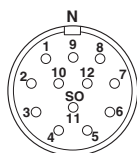

Dimensional drawing

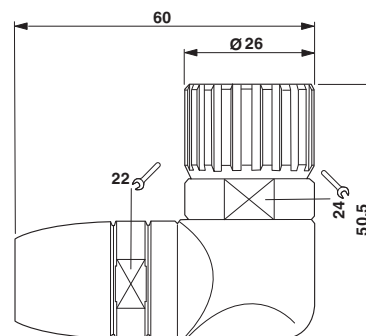

## Cable connector - RC-12S1N8AT006 - 1599319

### Approvals

Approvals

---

Approvals

EAC

---

Ex Approvals

---

### Approval details

EAC		B.01742
-----	-----------------------------------------------------------------------------------	---------

---

Phoenix Contact 2018 © - all rights reserved  
<http://www.phoenixcontact.com>

PHOENIX CONTACT GmbH & Co. KG  
Flachsmarktstr. 8  
32825 Blomberg  
Germany  
Tel. +49 5235 300  
Fax +49 5235 3 41200  
<http://www.phoenixcontact.com>

# Mouser Electronics

Authorized Distributor

Click to View Pricing, Inventory, Delivery & Lifecycle Information:

[Phoenix Contact:](#)

[1599319](#)