

Antenna - RAD-ISM-900-ANT-YAGI-10-N - 5606614

Please be informed that the data shown in this PDF Document is generated from our Online Catalog. Please find the complete data in the user's documentation. Our General Terms of Use for Downloads are valid (<http://phoenixcontact.com/download>)



Directional antenna 868 MHz / 900 MHz, gain: 12 dBi, polarization: linear, opening angle: h/v 56°/46°, degree of protection: IP65, connection: N (female), incl. mounting bracket and mast clips

Your advantages

- For large distances
- For point-to-point connections

Key Commercial Data

Packing unit	1 pc
GTIN	
GTIN	4046356686419

Technical data

Dimensions

Width	60.5 mm
Height	172 mm
Length	609.6 mm

Ambient conditions

Degree of protection	IP65
Ambient temperature (operation)	-40 °C ... 80 °C

General

With connecting cable	yes
Frequency range	900 MHz
	868 MHz ... 960 MHz
Horizontal beamwidth	56 °
Vertical beamwidth	46 °
Polarization	Linear vertical or horizontal

Antenna - RAD-ISM-900-ANT-YAGI-10-N - 5606614

Technical data

General

Impedance	50 Ω
Gain	12.15 dBi
Wind velocity	200 km/h
Connection method	N (female) with cable (0.6 m)
Material	Aluminum (Antenna housing)
	V2A (Bracket)
	V2A (U-shaped screw)
Mounting type	Mast mounting
External diameter	32 mm ... 60 mm (Mast)

Environmental Product Compliance

China RoHS	Environmentally friendly use period: unlimited = EFUP-e
	No hazardous substances above threshold values

Drawings

Antenna - RAD-ISM-900-ANT-YAGI-10-N - 5606614

Schematic diagram

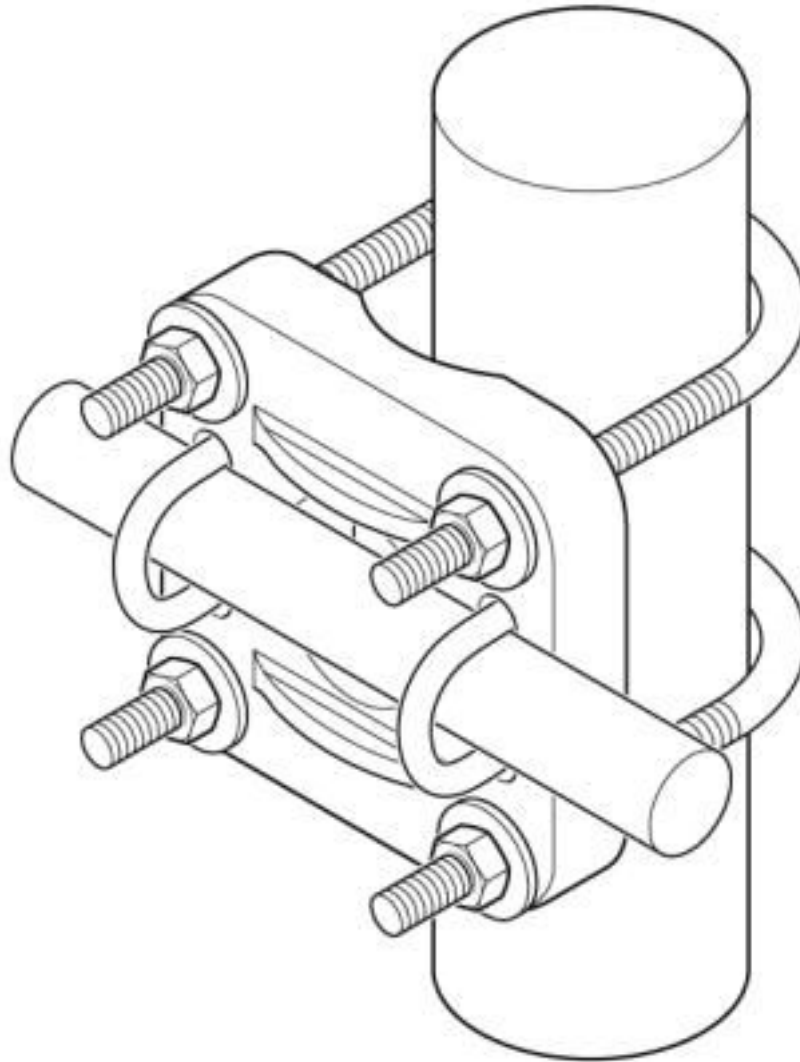

Mast mounting

Antenna - RAD-ISM-900-ANT-YAGI-10-N - 5606614

Schematic diagram

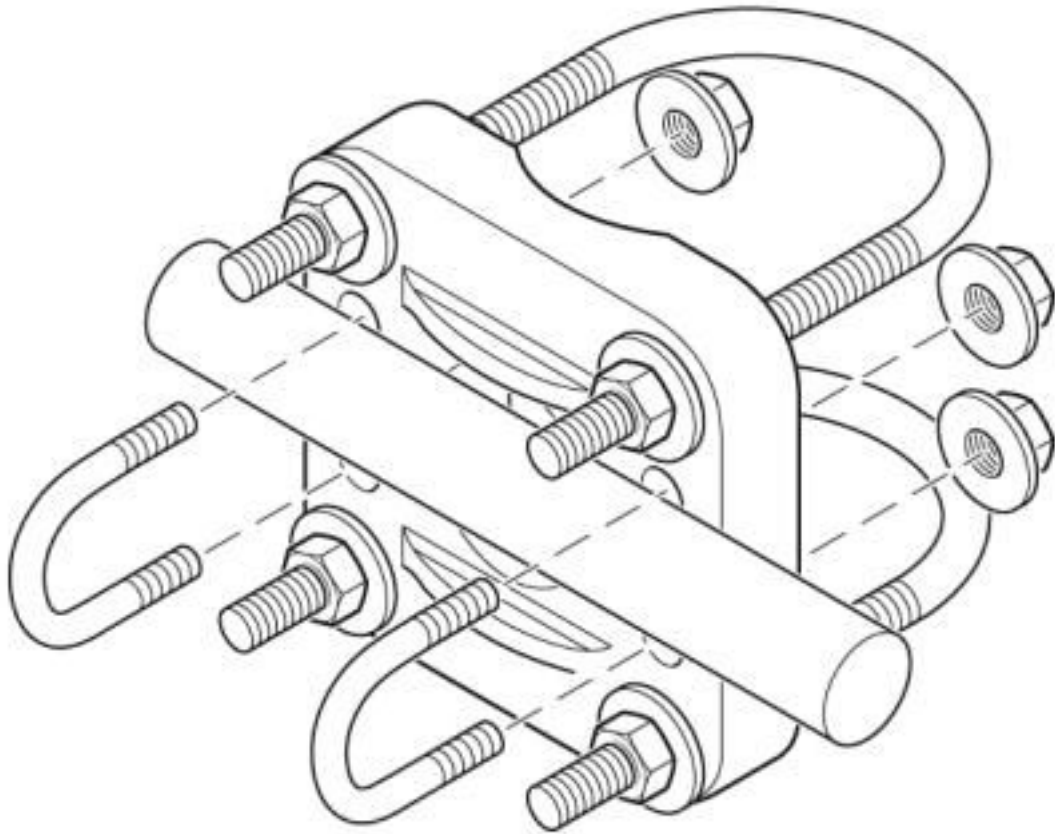

Schematic diagram

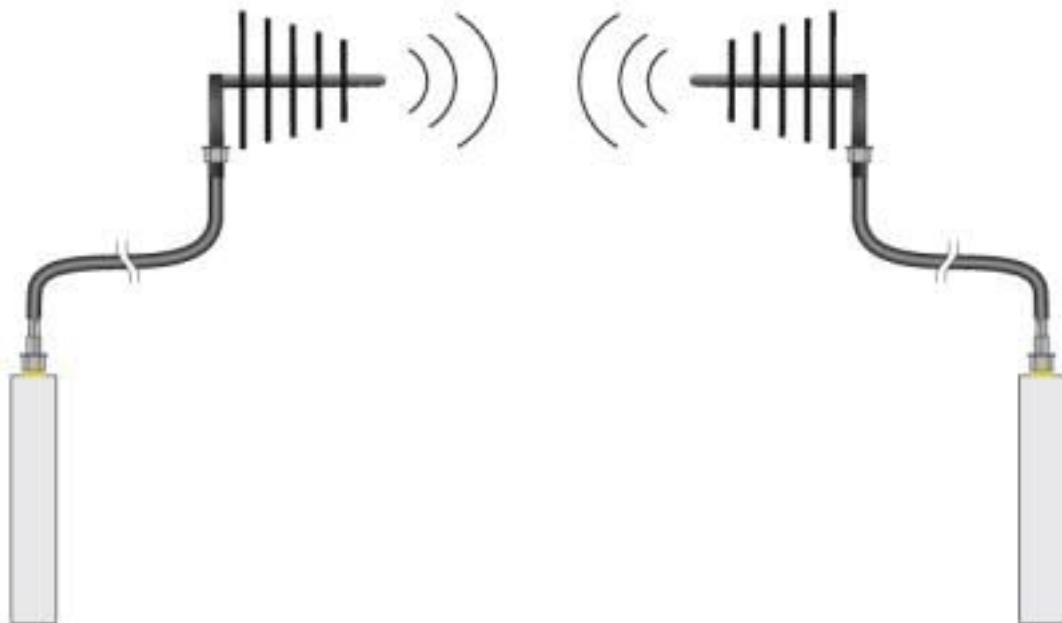

Antenna - RAD-ISM-900-ANT-YAGI-10-N - 5606614

Classifications

eCl@ss

eCl@ss 10.0.1	19070105
eCl@ss 4.0	27250300
eCl@ss 4.1	27250300
eCl@ss 5.0	19070100
eCl@ss 5.1	19070100
eCl@ss 6.0	19070100
eCl@ss 7.0	19070105
eCl@ss 8.0	19070105
eCl@ss 9.0	19070105

ETIM

ETIM 3.0	EC001698
ETIM 4.0	EC000019
ETIM 5.0	EC001698
ETIM 6.0	EC001698
ETIM 7.0	EC001698

UNSPSC

UNSPSC 6.01	43171611
UNSPSC 7.0901	43221706
UNSPSC 11	43171611
UNSPSC 12.01	43221706
UNSPSC 13.2	43221715
UNSPSC 18.0	43221715
UNSPSC 19.0	43221715
UNSPSC 20.0	43221715
UNSPSC 21.0	43221715

Phoenix Contact 2020 © - all rights reserved
<http://www.phoenixcontact.com>

PHOENIX CONTACT GmbH & Co. KG
Flachsmarktstr. 8
32825 Blomberg
Germany
Tel. +49 5235 300
Fax +49 5235 3 41200
<http://www.phoenixcontact.com>

Mouser Electronics

Authorized Distributor

Click to View Pricing, Inventory, Delivery & Lifecycle Information:

[Phoenix Contact:](#)

[5606614](#)