

Panel feed-through terminal block - UWV 25 - 3073445

Please be informed that the data shown in this PDF Document is generated from our Online Catalog. Please find the complete data in the user's documentation. Our General Terms of Use for Downloads are valid (<http://phoenixcontact.com/download>)



Panel feed-through terminal block, connection method: Screw connection with tension sleeve, Screw connection with tension sleeve, number of positions: 1, load current: 101 A, cross section: 6 mm² - 35 mm², connection direction of the conductor to plug-in direction: -90 °, width: 15.1 mm, color: gray

The figure shows a 7-position version

Your advantages

- ✓ Easy grouping with engagement pin versions
- ✓ Both terminal halves can be easily assembled by simply snapping them together
- ✓ Molded versions ensure maximum tightness of seal
- ✓ Touch-proof insulating housing in a new design
- ✓ Spacer plates increase clearances and creepage distances
- ✓ Automatic compensation of the panel thickness via the snap principle integrated in the insulation housing
- ✓ Universal screw connection with screw locking
- ✓ Well-known connection principle allows worldwide use
- ✓ Low temperature rise, thanks to maximum contact force
- ✓ Tool-free snap-in principle enables easy mounting on the device panel
- ✓ Automatic panel thickness compensation enables universal use



Key Commercial Data

Packing unit	25 pc
Minimum order quantity	25 pc
GTIN	
GTIN	4046356344746

Technical data

Item properties

Brief article description	Panel feed-through terminal block
Range of articles	UWV 25
Pitch	15.1 mm

Panel feed-through terminal block - UWV 25 - 3073445

Technical data

Item properties

Number of positions	1
Connection method	Screw connection with tension sleeve
Number of connections	2
Number of potentials	1

Electrical parameters

Nominal current	101 A
Nom. voltage	630 V
Rated voltage	630 V
Rated surge voltage (III/3)	6 kV

Connection capacity, external

Connection method	Screw connection with tension sleeve
Connection direction of the conductor to plug-in direction	-90 °
Conductor cross section solid	6 mm ² ... 35 mm ²
Conductor cross section flexible	10 mm ² ... 25 mm ²
Conductor cross section flexible, with ferrule without plastic sleeve	4 mm ² ... 25 mm ²
Conductor cross section, flexible, with ferrule, with plastic sleeve	4 mm ² ... 25 mm ²
2 conductors with same cross section, solid	2.5 mm ² ... 10 mm ²
2 conductors with same cross section, flexible	4 mm ² ... 10 mm ²
2 conductors with same cross section, flexible, with ferrule without plastic sleeve	2.5 mm ² ... 10 mm ²
2 conductors with the same cross section, flexible, with TWIN ferrule with plastic sleeve	2.5 mm ² ... 10 mm ²
Internal cylindrical gage	B7
Stripping length	19 mm
Torque	4 Nm ... 4.5 Nm

Connection capacity, internal

Connection method	Screw connection with tension sleeve
Connection direction of the conductor to plug-in direction	0 °
Conductor cross section solid	6 mm ² ... 35 mm ²
Conductor cross section flexible	10 mm ² ... 25 mm ²
Conductor cross section flexible, with ferrule without plastic sleeve	4 mm ² ... 25 mm ²
Conductor cross section, flexible, with ferrule, with plastic sleeve	4 mm ² ... 25 mm ²
2 conductors with same cross section, solid	2.5 mm ² ... 10 mm ²
2 conductors with same cross section, flexible	4 mm ² ... 10 mm ²
2 conductors with same cross section, flexible, with ferrule without plastic sleeve	2.5 mm ² ... 10 mm ²
2 conductors with the same cross section, flexible, with TWIN ferrule with plastic sleeve	2.5 mm ² ... 10 mm ²
Internal cylindrical gage	B7
Stripping length	19 mm
Torque	4 Nm ... 4.5 Nm

Panel feed-through terminal block - UWV 25 - 3073445

Technical data

Material data - contact

Note	WEEE/RoHS-compliant, free of whiskers according to IEC 60068-2-82/ JEDEC JESD 201
Contact material	Cu alloy
Surface characteristics	tin-plated

Material data - housing

Housing color	gray (7042)
Insulating material	PA
Insulating material group	I
CTI according to IEC 60112	600
Flammability rating according to UL 94	V0
Glow wire flammability index GWFI according to EN 60695-2-12	850
Glow wire ignition temperature GWIT according to EN 60695-2-13	775
Temperature for the ball pressure test according to EN 60695-10-2	125 °C

Dimensions for the product

Width [w]	15.1 mm
Pitch	15.1 mm

Dimensions for mounting cutout

Plate thickness	1 mm ... 6 mm
-----------------	---------------

Packaging information

Pieces per package	25
Denomination packing units	Pcs.

General product information

Type of note	Notes on safety
Note	The cable entry funnel is not touch-proof. Never connect or disconnect the terminal when it is energized. Take appropriate steps to ensure touch proofness.

Termination and connection method

Test for conductor damage and slackening	IEC 60947-7-1:2009-04
	Test passed

Pull-out test

Pull-out test	IEC 60947-7-1:2009-04
	Test passed
Conductor cross section / conductor type / tensile force	6 mm ² / solid / > 80 N
	10 mm ² / flexible / > 90 N
	35 mm ² / stranded / > 190 N
	25 mm ² / flexible / > 135 N

Mechanical tests according to standard

Test specification	IEC 60947-7-1 (following)
--------------------	---------------------------

Panel feed-through terminal block - UWV 25 - 3073445

Technical data

Electrical tests

Rated current	101 A
Conductor cross section	25 mm ²

Air clearances and creepage distances

Clearances and creepage distances	without spacer plate IEC 60947-7-1:2009-04
Application	without spacer plate
Specification	IEC 60947-7-1:2009-04
Minimum clearance - inhomogeneous field (III/3)	5.5 mm
Minimum creepage distance value (III/3)	8 mm

Temperature-rise test

Specification	IEC 60947-7-1:2009-04
Result	Test passed
Requirement temperature-rise test	Increase in temperature ≤ 45 K

Standards and Regulations

Connection in acc. with standard	UL
	IEC 60947-7-1
Flammability rating according to UL 94	V0
Safety note	<ul style="list-style-type: none"> • WARNING: Only electrically qualified personnel may install and operate the product. They must observe the following safety notes. The qualified personnel must be familiar with the basics of electrical engineering. They must be able to recognize and prevent danger. The relevant symbol on the packaging indicates that only personnel familiar with electrical engineering are allowed to install and operate the product. • The installation notes/Design In documents online on the download page at phoenixcontact.com/products must be observed for this product. • The cable entry funnel is not safe to touch. Never connect or disconnect the terminal when it is energized. Take appropriate steps to ensure touch protection.

Glow-wire test

Specification	IEC 60695-2-11:2000-10
Result	Test passed
Temperature	960 °C
Time of exposure	30 s

Needle flame test

Specification	IEC 60947-7-1:2009-04
Result	Test passed
Time of exposure	30 s

Environmental Product Compliance

China RoHS	Environmentally friendly use period: unlimited = EFUP-e
	No hazardous substances above threshold values

Drawings

Panel feed-through terminal block - UWV 25 - 3073445

Dimensional drawing

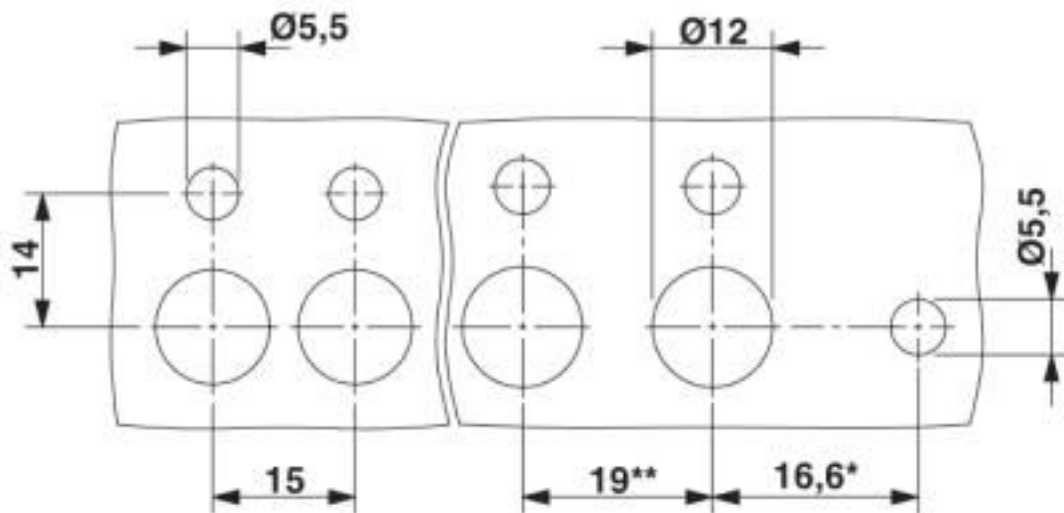

* Only when using the UW...-F flange plate

** Dimensions when using the DP-UW... spacer plate

Dimensional drawing

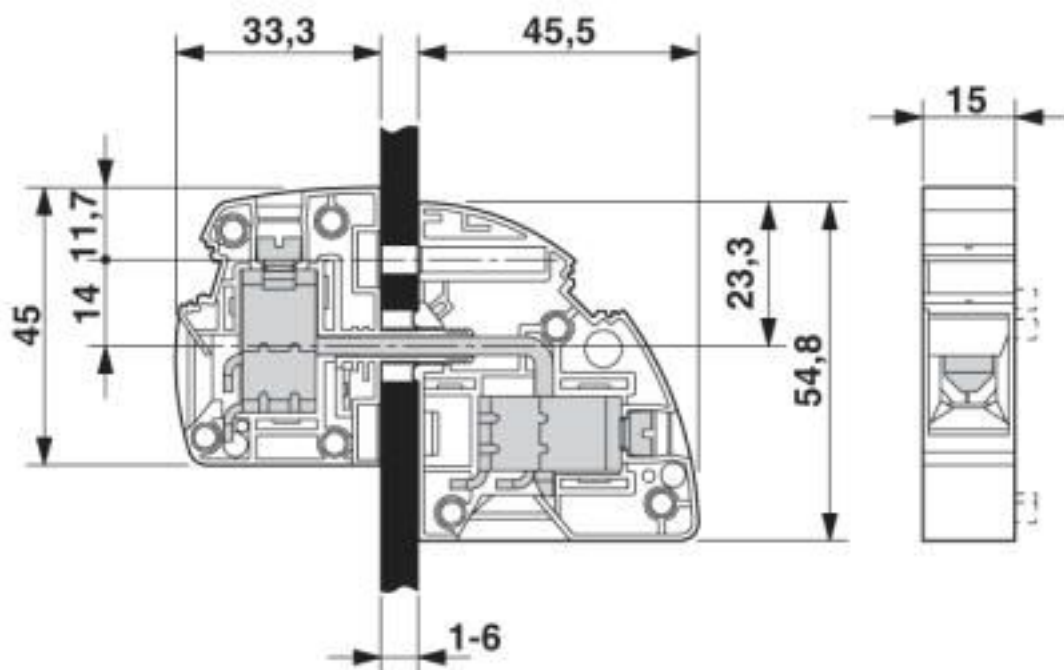

Classifications

eCl@ss

eCl@ss 10.0.1	27141134
eCl@ss 4.0	27141100

Panel feed-through terminal block - UWV 25 - 3073445

Classifications

eCl@ss

eCl@ss 4.1	27141100
eCl@ss 5.0	27141100
eCl@ss 5.1	27141100
eCl@ss 6.0	27141100
eCl@ss 7.0	27141134
eCl@ss 8.0	27141134
eCl@ss 9.0	27141134

ETIM

ETIM 2.0	EC001283
ETIM 3.0	EC001283
ETIM 4.0	EC001283
ETIM 5.0	EC001283
ETIM 6.0	EC001283
ETIM 7.0	EC001283

UNSPSC

UNSPSC 6.01	30211811
UNSPSC 7.0901	39121410
UNSPSC 11	39121410
UNSPSC 12.01	39121410
UNSPSC 13.2	39121410
UNSPSC 18.0	39121410
UNSPSC 19.0	39121410
UNSPSC 20.0	39121410
UNSPSC 21.0	39121410

Approvals

Approvals

Approvals

EAC / cULus Recognized

Ex Approvals

Approval details

Panel feed-through terminal block - UWV 25 - 3073445

Approvals

EAC		B.01687
-----	--	---------

cULus Recognized		http://database.ul.com/cgi-bin/XYV/template/LISEXT/1FRAME/index.htm	E60425-20100423
	B	C	
Nominal voltage UN	600 V	600 V	
Nominal current IN	112.5 A	112.5 A	
mm ² /AWG/kcmil	10-2	10-2	

Accessories

Accessories

Crimping tool

Crimping pliers - CRIMPFOX 6 - 1212034



Crimping pliers, for ferrules without insulating collar according to DIN 46228 Part 1 and ferrules with insulating collar according to DIN 46228 Part 4, 0.25 mm² ... 6.0 mm², lateral entry, trapezoidal crimp

Crimping pliers - CRIMPFOX 25R - 1212039



Crimping pliers, for ferrules without insulating collar according to DIN 46228 Part 1 and ferrules with insulating collar according to DIN 46228 Part 4, 10 mm² ... 25 mm², lateral entry, WM crimp

Crimping pliers - CRIMPFOX 50R - 1212041



Crimping pliers, for ferrules without insulating collar according to DIN 46228 Part 1 and ferrules with insulating collar according to DIN 46228 Part 4, 35 mm² ... 50 mm², lateral entry, WM crimp

Screwdriver tools

Panel feed-through terminal block - UWV 25 - 3073445

Accessories

Screwdriver - SZS 1,0X6,5 VDE - 1205079



Screwdriver, slot-headed, VDE insulated, size: 1.0 x 6.5 x 150 mm, 2-component grip, with non-slip grip

Terminal marking

Zack marker strip - ZB 15:UNBEDRUCKT - 0811972



Zack marker strip, Strip, white, unlabeled, can be labeled with: PLOTMARK, CMS-P1-PLOTTER, mounting type: snap into tall marker groove, for terminal block width: 15.2 mm, lettering field size: 10.5 x 15.1 mm, Number of individual labels: 5

Zack Marker strip, flat - ZBF 15:UNBEDRUCKT - 0811202



Zack Marker strip, flat, Strip, white, unlabeled, can be labeled with: PLOTMARK, CMS-P1-PLOTTER, mounting type: snap into flat marker groove, for terminal block width: 15 mm, lettering field size: 15 x 5.2 mm, Number of individual labels: 5

Marker for terminal blocks - TMT 100 R - 0816605



Marker for terminal blocks, Roll, white, unlabeled, can be labeled with: THERMOMARK ROLL 2.0, THERMOMARK ROLL, THERMOMARK ROLL X1, THERMOMARK ROLLMASTER 300/600, THERMOMARK X1.2, THERMOMARK S1.1, unperforated, mounting type: snap into universal marker groove, snap into flat marker groove, for terminal block width: 100 mm, lettering field size: 6.35 x 101.5 mm, Number of individual labels: 1000

Marker for terminal blocks - TMT (EX9,5)R - 0828295



Marker for terminal blocks, Roll, white, unlabeled, can be labeled with: THERMOMARK ROLL 2.0, THERMOMARK ROLL, THERMOMARK ROLL X1, THERMOMARK ROLLMASTER 300/600, THERMOMARK X1.2, mounting type: snap into universal marker groove, snap into tall marker groove, for terminal block width: 50000 mm, lettering field size: 9.5 x 50000 mm, Number of individual labels: 1

Phoenix Contact 2020 © - all rights reserved
<http://www.phoenixcontact.com>

PHOENIX CONTACT GmbH & Co. KG
Flachmarktstr. 8
32825 Blomberg
Germany
Tel. +49 5235 300
Fax +49 5235 3 41200
<http://www.phoenixcontact.com>

Mouser Electronics

Authorized Distributor

Click to View Pricing, Inventory, Delivery & Lifecycle Information:

[Phoenix Contact:](#)

[3073445](#)