

Starter kit - STME 6-SET POWER - 3035988

Please be informed that the data shown in this PDF Document is generated from our Online Catalog. Please find the complete data in the user's documentation. Our General Terms of Use for Downloads are valid (<http://phoenixcontact.com/download>)



Starter kit - consisting of test disconnect terminal blocks with spring-cage connection technology, marking material, bridging and test accessories. A terminal strip for a three-phase transformer circuit (current and voltage) can be configured individually.



COMPLIANT

Key Commercial Data

Packing unit	1 pc
GTIN	 4 046356 428255
GTIN	4046356428255

Technical data

General

Note	Quantity specifications on the set contents under downloads
Set consists of	3035700 STME 6
	3035713 STMED 6
	3035726 STMED 6-PE
	0311139 ATP-URTK/SP
	3034387 CARRIER 35-8
	3034468 SB-ME 2-8
	3030284 FBS 2-8
	3032389 FBS 1/3/5-8
	3032745 PAI-4-FIX YE
	3032758 PAI-4-FIX GN
	3032761 PAI-4-FIX VT
	3032729 PAI-4-FIX BU
	3034439 S-ME 6
	3022276 CLIPFIX 35-5
	0811969 KLM 3
	0819327 UC-EMLP (20X8)

Starter kit - STME 6-SET POWER - 3035988

Technical data

General

	0818072 UC-TM 8
	0818137 UC-TMF 8
Ambient temperature (operation)	-60 °C ... 85 °C
Ambient temperature (storage/transport)	-25 °C ... 55 °C (For a short time, not exceeding 24 h, -60 to +70 °C)
Permissible humidity (storage/transport)	30 % ... 70 %
Ambient temperature (assembly)	-5 °C ... 70 °C
Ambient temperature (actuation)	-5 °C ... 70 °C

Dimensions

Width	225 mm
Length	315 mm
Height	65 mm

Connection data

Connection method	Spring-cage connection
-------------------	------------------------

Environmental Product Compliance

REACH SVHC	Lead 7439-92-1
China RoHS	Environmentally friendly use period: unlimited = EFUP-e
	No hazardous substances above threshold values

Drawings

Circuit diagram

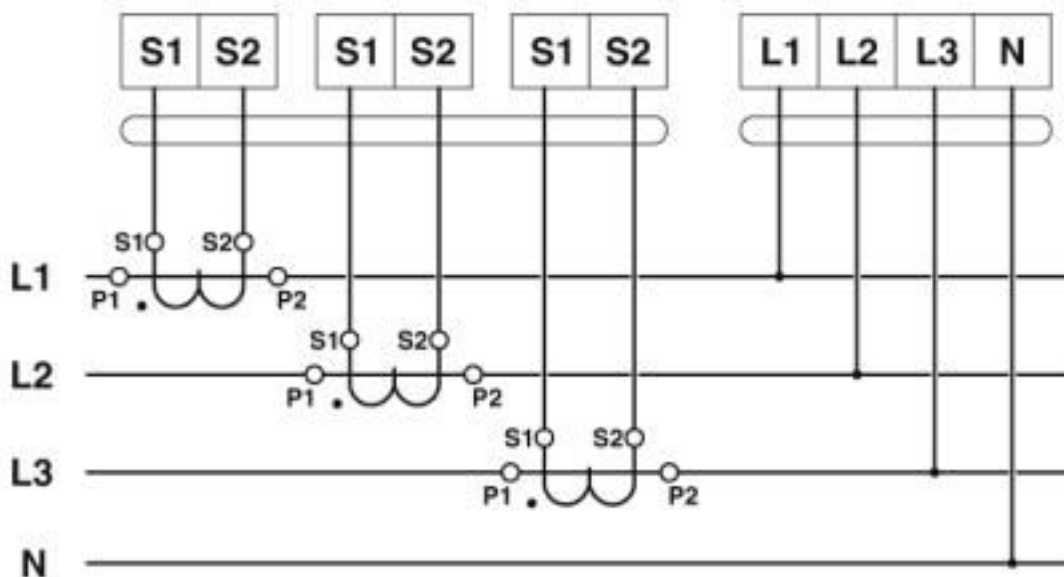

Starter kit - STME 6-SET POWER - 3035988

Circuit diagram

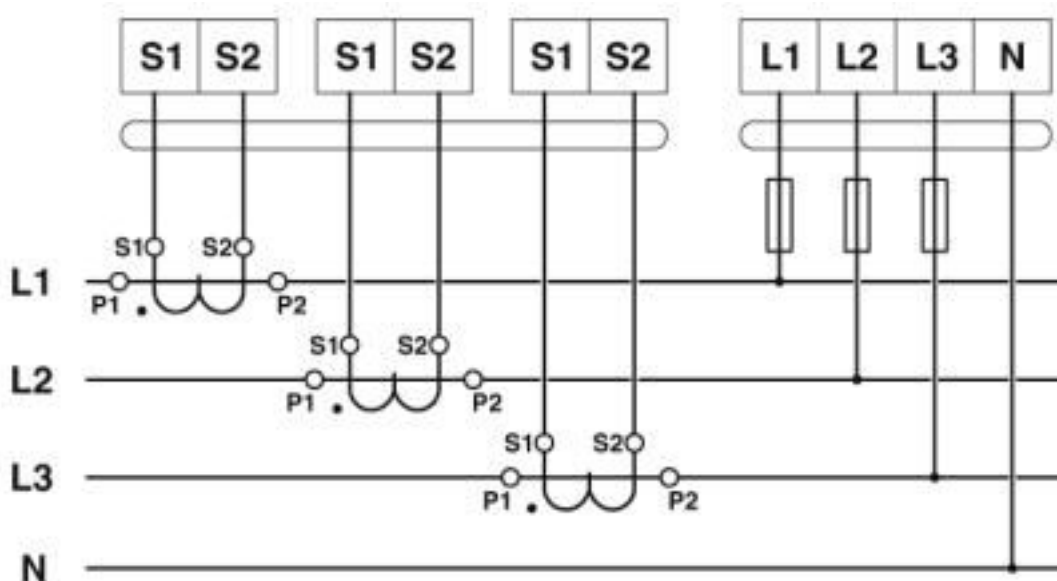

Articles in set

Test disconnect terminal block - STME 6 - 3035700



Test disconnect terminal block, nom. voltage: 500 V, nominal current: 30 A, connection method: Spring-cage connection, number of connections: 2, cross section: 0.2 mm² - 10 mm², AWG: 24 - 8, width: 8.2 mm, color: gray, mounting type: NS 35/7,5, NS 35/15

Feed-through terminal block - STMED 6 - 3035713



Feed-through terminal block, nom. voltage: 1000 V, nominal current: 41 A, connection method: Spring-cage connection, number of connections: 2, cross section: 0.2 mm² - 10 mm², AWG: 24 - 8, width: 8.2 mm, color: gray, mounting type: NS 35/7,5, NS 35/15

Ground modular terminal block - STMED 6-PE - 3035726



Ground modular terminal block, connection method: Spring-cage connection, number of connections: 2, cross section: 0.2 mm² - 10 mm², AWG: 24 - 8, width: 8.2 mm, color: green-yellow, mounting type: NS 35/7,5, NS 35/15

Starter kit - STME 6-SET POWER - 3035988

Articles in set

Partition plate - ATP-URTK/SP - 0311139



Partition plate, length: 99 mm, width: 2 mm, height: 64 mm, color: gray

Partition plate - CARRIER 35-8 - 3034387



Partition plate, width: 8.2 mm, material: PA, length: 99.8 mm, With storage option for FBS...-8 and PAI 4-FIX, color: gray

Switching jumper - SB-ME 2-8 - 3034468



Switching jumper, pitch: 8.2 mm, length: 24.7 mm, width: 16.4 mm, number of positions: 2, color: gray/orange

Plug-in bridge - FBS 2-8 - 3030284



Plug-in bridge, pitch: 8.2 mm, width: 14.7 mm, number of positions: 2, color: red

Plug-in bridge - FBS 1/3/5-8 - 3032389



Plug-in bridge, pitch: 8.2 mm, width: 39.3 mm, number of positions: 5, pin assignment: 1,3,5, color: red

Starter kit - STME 6-SET POWER - 3035988

Articles in set

Test adapter - PAI-4-FIX YE - 3032745



Test adapter, for 4 mm test plug and terminal blocks with 8.2 mm pitch, color: yellow

Test adapter - PAI-4-FIX GN - 3032758



Test adapter, for 4 mm test plug and terminal blocks with 8.2 mm pitch, color: green

Test adapter - PAI-4-FIX VT - 3032761



Test adapter, for 4 mm test plug and terminal blocks with 4.2 mm ... 8.2 mm pitch, color: violet

Test adapter - PAI-4-FIX BU - 3032729



Test adapter, for 4 mm test plug and terminal blocks with 8.2 mm pitch, color: blue

Switching lock - S-ME 6 - 3034439



Switching lock, length: 12 mm, width: 8.2 mm, color: white

Starter kit - STME 6-SET POWER - 3035988

Articles in set

End clamp - CLIPFIX 35-5 - 3022276



Quick mounting end clamp for NS 35/7,5 DIN rail or NS 35/15 DIN rail, with marking option, with parking option for FBS...5, FBS...6, KSS 5, KSS 6, width: 5.15 mm, color: gray

Terminal strip marker carrier - KLM 3 - 0811969



Terminal strip marker carrier, height-adjustable, for end brackets CLIPFIX 15, CLIPFIX 35 and CLIPFIX 35-5, can be labeled with BMK...20 x 8 labels, or directly with the M-PEN or X-PEN

Plastic label - UC-EMLP (20X8) - 0819327



Plastic label, Sheet, white, unlabeled, can be labeled with: BLUEMARK ID COLOR, BLUEMARK ID, BLUEMARK CLED, PLOTMARK, CMS-P1-PLOTTER, mounting type: adhesive, lettering field size: 20 mm x 8 mm, Number of individual labels: 10

Marker for terminal blocks - UC-TM 8 - 0818072



Marker for terminal blocks, Sheet, white, unlabeled, can be labeled with: BLUEMARK ID COLOR, BLUEMARK ID, BLUEMARK CLED, PLOTMARK, CMS-P1-PLOTTER, mounting type: snap into tall marker groove, for terminal block width: 8.2 mm, lettering field size: 7.6 x 10.5 mm, Number of individual labels: 56

Marker for terminal blocks - UC-TMF 8 - 0818137



Marker for terminal blocks, Sheet, white, unlabeled, can be labeled with: BLUEMARK ID COLOR, BLUEMARK ID, BLUEMARK CLED, PLOTMARK, CMS-P1-PLOTTER, mounting type: snap into flat marker groove, for terminal block width: 8.2 mm, lettering field size: 7.6 x 5.1 mm, Number of individual labels: 56

Classifications

eCl@ss

eCl@ss 10.0.1	27141190
eCl@ss 4.0	27141100

Starter kit - STME 6-SET POWER - 3035988

Classifications

eCl@ss

eCl@ss 4.1	27141100
eCl@ss 5.0	27141100
eCl@ss 5.1	27141100
eCl@ss 6.0	27141100
eCl@ss 7.0	27141190
eCl@ss 8.0	27141190
eCl@ss 9.0	27141190

ETIM

ETIM 3.0	EC000897
ETIM 4.0	EC000902
ETIM 5.0	EC002848
ETIM 6.0	EC002848
ETIM 7.0	EC002848

UNSPSC

UNSPSC 6.01	30211811
UNSPSC 7.0901	39121410
UNSPSC 11	39121410
UNSPSC 12.01	39121410
UNSPSC 13.2	39121410
UNSPSC 18.0	39121410
UNSPSC 19.0	39121410
UNSPSC 20.0	39121410
UNSPSC 21.0	39121410

Approvals

Approvals

Approvals

EAC / EAC

Ex Approvals

Approval details

EAC		RU C- DE.A*30.B.01742
-----	--	--------------------------

Starter kit - STME 6-SET POWER - 3035988

Approvals

EAC		RU C- DE.BL08.B.00644
-----	--	--------------------------

Accessories

Accessories

DIN rail

DIN rail perforated - NS 35/ 7,5 PERF 2000MM - 0801733



DIN rail perforated, Standard profile, width: 35 mm, height: 7.5 mm, acc. to EN 60715, material: Steel, galvanized, passivated with a thick layer, length: 2000 mm, color: silver

DIN rail, unperforated - NS 35/ 7,5 UNPERF 2000MM - 0801681



DIN rail, unperforated, Standard profile, width: 35 mm, height: 7.5 mm, acc. to EN 60715, material: Steel, galvanized, passivated with a thick layer, length: 2000 mm, color: silver

DIN rail perforated - NS 35/ 7,5 WH PERF 2000MM - 1204119



DIN rail perforated, Standard profile, width: 35 mm, height: 7.5 mm, acc. to EN 60715, material: Steel, Galvanized, white passivated, length: 2000 mm, color: silver

DIN rail, unperforated - NS 35/ 7,5 WH UNPERF 2000MM - 1204122



DIN rail, unperforated, Standard profile, width: 35 mm, height: 7.5 mm, acc. to EN 60715, material: Steel, Galvanized, white passivated, length: 2000 mm, color: silver

Starter kit - STME 6-SET POWER - 3035988

Accessories

DIN rail, unperforated - NS 35/ 7,5 AL UNPERF 2000MM - 0801704



DIN rail, unperforated, Standard profile, width: 35 mm, height: 7.5 mm, acc. to EN 60715, material: Aluminum, uncoated, length: 2000 mm, color: silver

DIN rail perforated - NS 35/ 7,5 ZN PERF 2000MM - 1206421



DIN rail perforated, Standard profile, width: 35 mm, height: 7.5 mm, acc. to EN 60715, material: Steel, galvanized, length: 2000 mm, color: silver

DIN rail, unperforated - NS 35/ 7,5 ZN UNPERF 2000MM - 1206434



DIN rail, unperforated, Standard profile, width: 35 mm, height: 7.5 mm, acc. to EN 60715, material: Steel, galvanized, length: 2000 mm, color: silver

DIN rail, unperforated - NS 35/ 7,5 CU UNPERF 2000MM - 0801762



DIN rail, unperforated, Standard profile, width: 35 mm, height: 7.5 mm, acc. to EN 60715, material: Copper, uncoated, length: 2000 mm, color: copper-colored

End cap - NS 35/ 7,5 CAP - 1206560

DIN rail end piece, for DIN rail NS 35/7.5



End block

Starter kit - STME 6-SET POWER - 3035988

Accessories

End clamp - E/AL-NS 35 - 1201662



End clamp, for end support of UKH 50 to UKH 240, is pushed onto DIN rail NS 35 and fixed with 2 screws, width: 10 mm, color: aluminum

Phoenix Contact 2020 © - all rights reserved
<http://www.phoenixcontact.com>

PHOENIX CONTACT GmbH & Co. KG
Flachsmarktstr. 8
32825 Blomberg
Germany
Tel. +49 5235 300
Fax +49 5235 3 41200
<http://www.phoenixcontact.com>

Mouser Electronics

Authorized Distributor

Click to View Pricing, Inventory, Delivery & Lifecycle Information:

Phoenix Contact:

3035988