

Functional block - EMG 17-REL/KSR-G 24/SO38 BK - 2949994

Please be informed that the data shown in this PDF Document is generated from our Online Catalog. Please find the complete data in the user's documentation. Our General Terms of Use for Downloads are valid (<http://phoenixcontact.com/download>)



Relay module for high inrush currents, with soldered-in relay, contacts (AgSnO² + capacitive W): medium to large loads, 1 N/O contact, input voltage 24 V DC, max. inrush current 80 A

Your advantages

- ✓ Can be snapped onto standard EN DIN rails
- ✓ Clear terminal marking using Phoenix Contact labeling material
- ✓ Modular DIN-rail mountable EMG housing with 17.5 mm design width
- ✓ User-friendly plug-in housing
- ✓ Easy maintenance



Key Commercial Data

Packing unit	10 pc
GTIN	 4 017918 083915
GTIN	4017918083915

Technical data

Note

Utilization restriction	EMC: class A product, see manufacturer's declaration in the download area
-------------------------	---

Dimensions

Width	17.5 mm
Height	75 mm
Depth	62.5 mm

Ambient conditions

Ambient temperature (operation)	-20 °C ... 50 °C
Ambient temperature (storage/transport)	-20 °C ... 70 °C

Coil side

Functional block - EMG 17-REL/KSR-G 24/SO38 BK - 2949994

Technical data

Coil side

Nominal input voltage U_N	24 V DC
Input voltage range in reference to U_N	0.85 ... 1.1
Typical input current at U_N	28 mA
Typical response time	13 ms
Typical release time	15 ms
Protective circuit	Free-wheeling diode Damping diode
Operating voltage display	Yellow LED
Power dissipation for nominal condition	0.67 W

Contact side

Contact type	1 N/O contact with lead contact
Type of switch contact	Lead contact
Contact material	AgSnO ₂
Note	Main contact silver tin oxide (AgSnO ₂): lead contact tungsten
Maximum switching voltage	250 V AC
Maximum inrush current	80 A (20 ms)
Limiting continuous current	10 A
Interrupting rating (ohmic load) max.	2500 VA (for 250 V AC)

General

Test voltage relay winding/relay contact	4 kV AC (50 Hz, 1 min.)
Mechanical service life	approx. 10 ⁷ cycles
Mounting position	any

Connection data

Connection name	Coil side
Connection method	Screw connection
Stripping length	8 mm
Screw thread	M3
Conductor cross section solid	0.2 mm ² ... 4 mm ²
Conductor cross section flexible	0.2 mm ² ... 2.5 mm ²
Conductor cross section AWG	24 ... 12

Connection data 2

Connection name	Contact side
Connection method	Screw connection
Stripping length	8 mm
Screw thread	M3
Conductor cross section solid	0.2 mm ² ... 4 mm ²
Conductor cross section flexible	0.2 mm ² ... 2.5 mm ²
Conductor cross section AWG	24 ... 12

Standards and Regulations

Functional block - EMG 17-REL/KSR-G 24/SO38 BK - 2949994

Technical data

Standards and Regulations

Connection in acc. with standard	CUL
Standards/regulations	IEC 60664
	EN 50178
Insulation	safe isolation
Pollution degree	2
Overvoltage category	III

Environmental Product Compliance

REACH SVHC	Lead 7439-92-1
China RoHS	Environmentally Friendly Use Period = 50 years
	For details about hazardous substances go to tab "Downloads", Category "Manufacturer's declaration"

Drawings

Circuit diagram

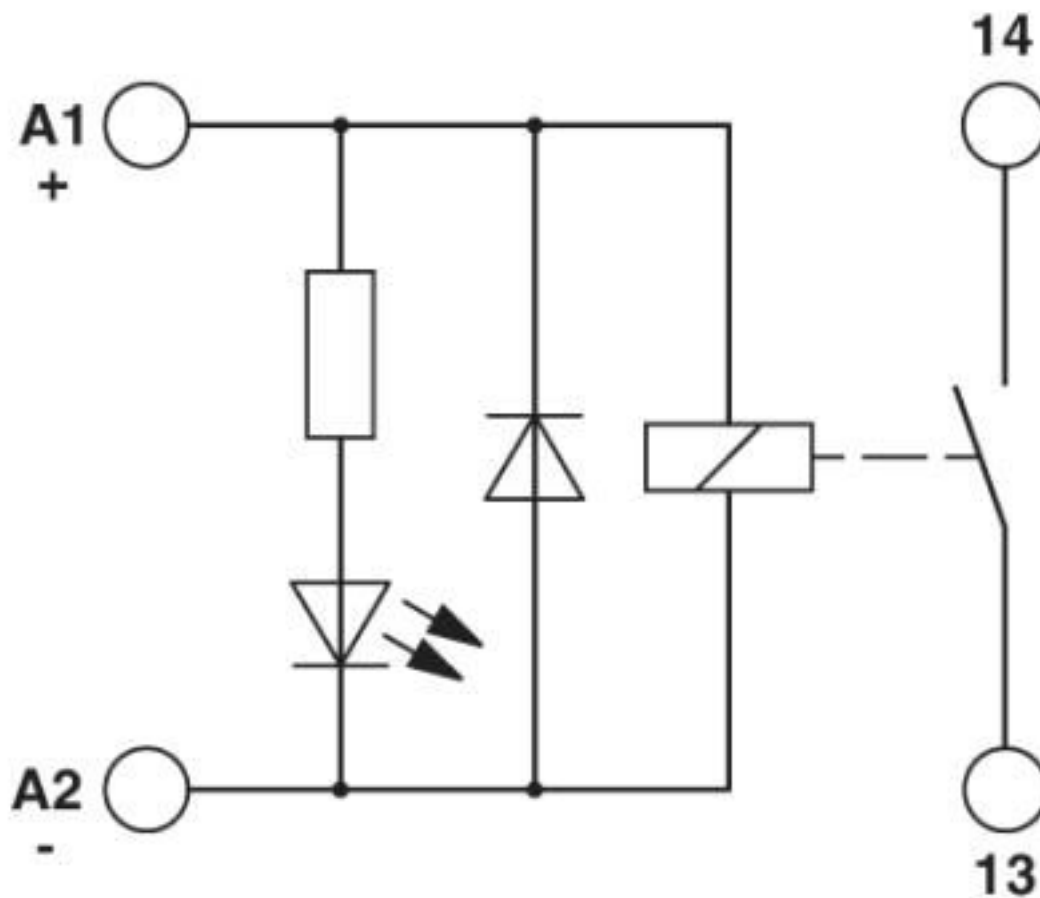

Functional block - EMG 17-REL/KSR-G 24/SO38 BK - 2949994

Classifications

eCl@ss

eCl@ss 10.0.1	27371601
eCl@ss 4.0	27371100
eCl@ss 4.1	27371100
eCl@ss 5.0	27371600
eCl@ss 5.1	27371600
eCl@ss 6.0	27371600
eCl@ss 7.0	27371601
eCl@ss 8.0	27371601
eCl@ss 9.0	27371601

ETIM

ETIM 2.0	EC001437
ETIM 3.0	EC001437
ETIM 4.0	EC001437
ETIM 5.0	EC001437
ETIM 6.0	EC001437
ETIM 7.0	EC001437

UNSPSC

UNSPSC 6.01	30211916
UNSPSC 7.0901	39121515
UNSPSC 11	39121515
UNSPSC 12.01	39121515
UNSPSC 13.2	39122334
UNSPSC 18.0	39122334
UNSPSC 19.0	39122334
UNSPSC 20.0	39122334
UNSPSC 21.0	39122334

Approvals

Approvals

Approvals

EAC

Ex Approvals

Approval details

Functional block - EMG 17-REL/KSR-G 24/SO38 BK - 2949994

Approvals

EAC		RU C- DE.A*30.B.01082
-----	---	--------------------------

Accessories

Accessories

Marking material - EMG-GKS 12 - 2947035



Device marking label, width: 12 mm, area: 12 x 8 mm, e.g. for EML(10x7) R adhesive marking material

Phoenix Contact 2020 © - all rights reserved
<http://www.phoenixcontact.com>

PHOENIX CONTACT GmbH & Co. KG
Flachsmarktstr. 8
32825 Blomberg
Germany
Tel. +49 5235 300
Fax +49 5235 3 41200
<http://www.phoenixcontact.com>

Mouser Electronics

Authorized Distributor

Click to View Pricing, Inventory, Delivery & Lifecycle Information:

[Phoenix Contact:](#)

[2949994](#)