

Relay Module - EMG 17-REL/SG-B 60/21/P - 2947491

Please be informed that the data shown in this PDF Document is generated from our Online Catalog. Please find the complete data in the user's documentation. Our General Terms of Use for Downloads are valid (<http://phoenixcontact.com/download>)



Relay module, with soldered-in remanence miniature switching relay, with positive switching diode wiring, contacts (AgSnO): small to large loads, 1 PDT, 60 V DC input voltage

The figure shows version EMG 17-REL, with soldered-in Latching miniature switching relay



Key Commercial Data

Packing unit	10 pc
GTIN	 4 017918 139315
GTIN	4017918139315

Technical data

Note

Utilization restriction	EMC: class A product, see manufacturer's declaration in the download area
-------------------------	---------------------------------------------------------------------------

Dimensions

Width	17.5 mm
Height	75 mm
Depth	62.5 mm

Ambient conditions

Ambient temperature (operation)	-40 °C ... 50 °C
Ambient temperature (storage/transport)	-40 °C ... 70 °C

Coil side

Nominal input voltage U_N	60 V DC
Input voltage range in reference to U_N	0.8 ... 1.1
Typical input current at U_N	typ. 9 mA
Typical response time	5 ms

Relay Module - EMG 17-REL/SG-B 60/21/P - 2947491

Technical data

Coil side

Typical release time	5 ms
Coil voltage	24 V DC
Protective circuit	Free-wheeling diode Damping diode
	Reverse polarity protection Polarity protection diode
Pulse time range	30 ms ... 5 s
Power dissipation for nominal condition	0.54 W

Contact side

Contact type	Single contact, 1-PDT
Type of switch contact	Single contact
Contact material	AgSnO
Maximum switching voltage	250 V AC/DC
Minimum switching voltage	5 V (at 100 mA)
	24 V (At 1 mA)
Min. switching current	1 mA (at 24 V)
	100 mA (At 5 V)
Maximum inrush current	8 A
Limiting continuous current	6 A
Interrupting rating (ohmic load) max.	144 W (at 24 V DC)
	43 W (at 48 V DC)
	42 W (at 60 V DC)
	55 W (at 110 V DC)
	100 W (at 220 V DC)
	1500 VA (for 250 V AC)

Contact side (with destroyed gold layer)

Maximum switching voltage	250 V AC/DC
Limiting continuous current	5 A
Maximum inrush current	6 A
Interrupting rating (ohmic load) max.	120 W (at 24 V DC)
	40 W (at 48 V DC)
	35 MW (at 60 V DC)
	30 W (at 110 V DC)
	55 W (at 220 V DC)
	1100 VA (for 250 V AC)

General

Test voltage relay winding/relay contact	4 kV _{rms} (50 Hz, 1 min.)
Operating mode	100% operating factor
Mechanical service life	approx. 10 ⁷ cycles
Mounting position	any
Assembly instructions	In rows with zero spacing

Relay Module - EMG 17-REL/SG-B 60/21/P - 2947491

Technical data

Connection data

Connection name	Coil side
Connection method	Screw connection
Stripping length	8 mm
Screw thread	M3
Conductor cross section solid	0.2 mm ² ... 4 mm ²
Conductor cross section flexible	0.2 mm ² ... 2.5 mm ²
Conductor cross section AWG	24 ... 12

Connection data 2

Connection name	Contact side
Connection method	Screw connection
Stripping length	8 mm
Screw thread	M3
Conductor cross section solid	0.2 mm ² ... 4 mm ²
Conductor cross section flexible	0.2 mm ² ... 2.5 mm ²
Conductor cross section AWG	24 ... 12

Standards and Regulations

Designation	Air clearances and creepage distances between the power circuits
Standards/regulations	DIN EN 50178
Rated insulation voltage	250 V AC
Rated surge voltage	4 kV
Insulation	Safe isolation, reinforced insulation
Pollution degree	2
Overvoltage category	III
Pollution degree	2
Overvoltage category	III

Environmental Product Compliance

REACH SVHC	Lead 7439-92-1
China RoHS	Environmentally Friendly Use Period = 50 years
	For details about hazardous substances go to tab "Downloads", Category "Manufacturer's declaration"

Drawings

Relay Module - EMG 17-REL/SG-B 60/21/P - 2947491

Circuit diagram

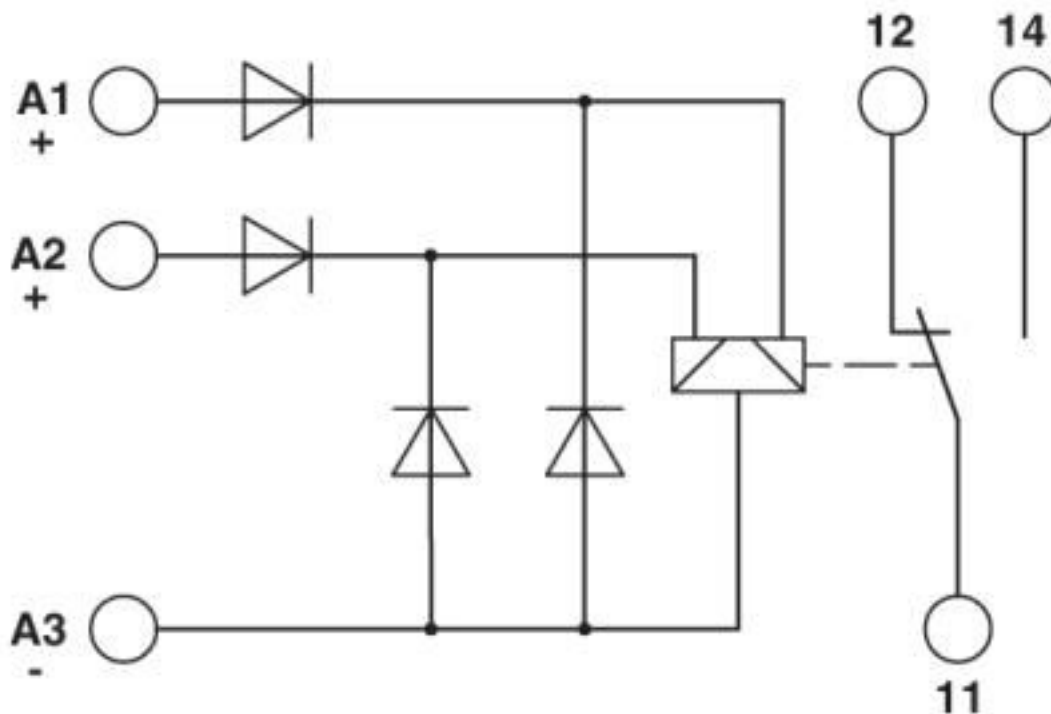

Classifications

eCl@ss

eCl@ss 4.0	27371100
eCl@ss 4.1	27371100
eCl@ss 5.0	27371600
eCl@ss 5.1	27371600
eCl@ss 6.0	27371600
eCl@ss 7.0	27371601
eCl@ss 8.0	27371601
eCl@ss 9.0	27371601

ETIM

ETIM 2.0	EC001437
ETIM 3.0	EC001437
ETIM 4.0	EC001437
ETIM 5.0	EC001437
ETIM 6.0	EC001437
ETIM 7.0	EC001437

UNSPSC

UNSPSC 6.01	30211916
UNSPSC 7.0901	39121515

Relay Module - EMG 17-REL/SG-B 60/21/P - 2947491

Classifications

UNSPSC

UNSPSC 11	39121515
UNSPSC 12.01	39121515
UNSPSC 13.2	39122334
UNSPSC 19.0	39122334

Approvals

Approvals

Approvals

EAC / EAC

Ex Approvals

Approval details

EAC		TR_TS_D_00573_c
-----	--	-----------------

EAC		RU*C- DE.*08.B.00010
-----	--	-------------------------

Accessories

Accessories

Marking material - EMG-GKS 12 - 2947035



Device marking label, width: 12 mm, area: 12 x 8 mm, e.g. for EML(10x7) R adhesive marking material

Phoenix Contact 2020 © - all rights reserved
<http://www.phoenixcontact.com>

PHOENIX CONTACT GmbH & Co. KG
Flachmarktstr. 8
32825 Blomberg
Germany
Tel. +49 5235 300
Fax +49 5235 3 41200
<http://www.phoenixcontact.com>

Mouser Electronics

Authorized Distributor

Click to View Pricing, Inventory, Delivery & Lifecycle Information:

[Phoenix Contact:](#)

[2947491](#)