

## Load relay - ELR 3/ 9-500 - 2941714

Please be informed that the data shown in this PDF Document is generated from our Online Catalog. Please find the complete data in the user's documentation. Our General Terms of Use for Downloads are valid (<http://phoenixcontact.com/download>)



Electronic load relay, for direct driving of equipment in the 3-phase network, with light indicator and protection circuit, output: 110-550 V AC/3 x 9 A

The figure shows the version ELR 3/9-400

### Your advantages

- Noise and wear-free switching up to 500 V AC/9 A
- High switching frequency
- Protective circuit in input and output
- Operating indicator



### Key Commercial Data

Packing unit	1 pc
GTIN	
GTIN	4017918104559

### Technical data

#### Note

Utilization restriction	EMC: class A product, see manufacturer's declaration in the download area
-------------------------	---

#### Dimensions

Width	62 mm
Height	84 mm
Depth	110 mm

#### Ambient conditions

Ambient temperature (operation)	-20 °C ... 60 °C
Ambient temperature (storage/transport)	-20 °C ... 70 °C
Degree of protection	IP20

# Load relay - ELR 3/ 9-500 - 2941714

## Technical data

### Input data

Input name	Control input right/left
Rated actuating voltage $U_c$	24 V DC
Triggering voltage range	19.2 V DC ... 28.8 V DC
Voltage range with reference to $U_c$	0.8 ... 1.2
Rated actuating current $I_c$	16 mA
Reaction time in normal load operation	20 ms
Transmission frequency	1 Hz (At $\cos \phi = 0.5$ )
Protective circuit	Reverse polarity protection Polarity protection diode
	Surge protection
Status display	Yellow LED

### Output data load output

Output name	AC output
Rated operating voltage $U_e$	500 V AC
Operating voltage range	110 V AC ... 550 V AC
Load current range	150 mA ... 9 A (see to derating)
Leakage current	typ. 7 mA
Residual voltage	typ. 1.5 V
Surge current	230 A ( $t_p = 10$ ms, at 25 °C)
Type of protection	RC element
Protective circuit/component	RC element
Type of protection	Surge protection

### General

Test voltage input/output	2.5 kV
Switching frequency	max. 10 Hz (At $\cos \phi = 0.5$ )
Mounting position	Vertical (horizontal DIN rail)
Assembly instructions	Can be aligned with > 20 mm spacing
Operating mode	100% operating factor

### Connection data

Connection name	Control circuits
Connection method	Screw connection
Stripping length	8 mm
Screw thread	M3
Conductor cross section solid	0.2 mm <sup>2</sup> ... 6 mm <sup>2</sup>
Conductor cross section flexible	0.2 mm <sup>2</sup> ... 4 mm <sup>2</sup>
Conductor cross section AWG	24 ... 10

### Connection data 2

Connection name	Load circuit
Connection method	Screw connection
Stripping length	8 mm

# Load relay - ELR 3/ 9-500 - 2941714

## Technical data

### Connection data 2

Screw thread	M3
Conductor cross section solid	0.2 mm <sup>2</sup> ... 6 mm <sup>2</sup>
Conductor cross section flexible	0.2 mm <sup>2</sup> ... 4 mm <sup>2</sup>
Conductor cross section AWG	24 ... 10

### Standards and Regulations

Designation	Air clearances and creepage distances between the power circuits
Standards/regulations	EN 50178
Insulation	Basic insulation
Designation	Power station requirements
	EMC regulations
Standards/regulations	EN 61000-6-2
	EN 61000-6-4

### Environmental Product Compliance

REACH SVHC	Lead 7439-92-1
China RoHS	Environmentally Friendly Use Period = 50 years
	For details about hazardous substances go to tab "Downloads", Category "Manufacturer's declaration"

## Drawings

# Load relay - ELR 3/ 9-500 - 2941714

Block diagram

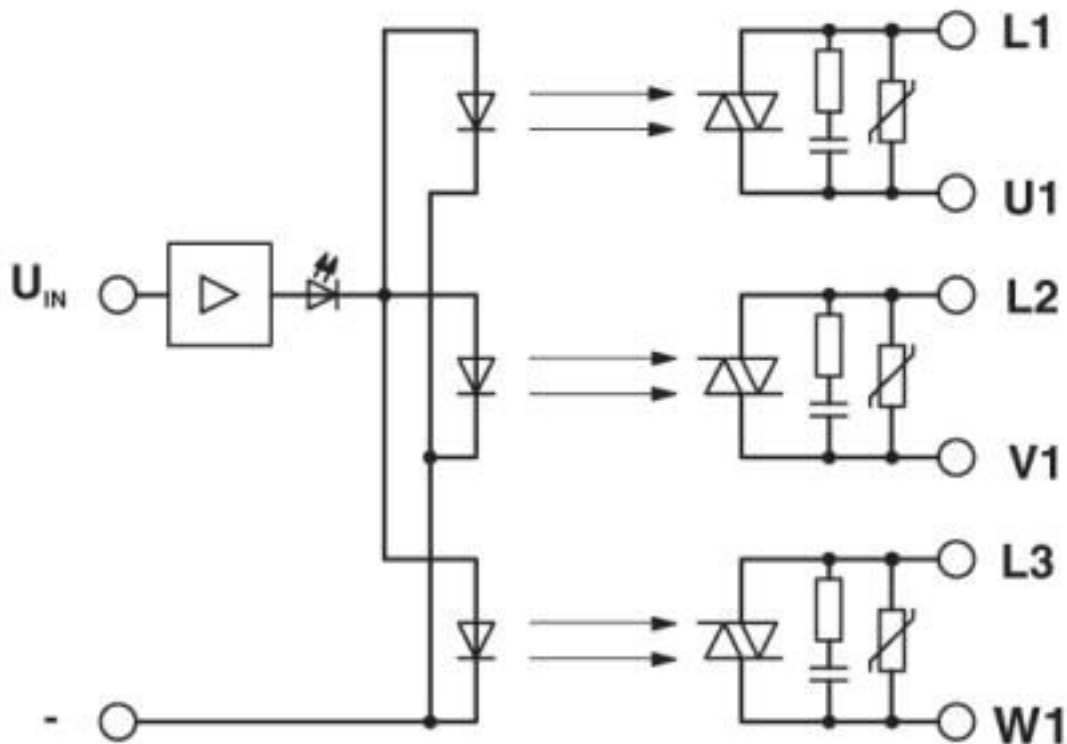

Diagram

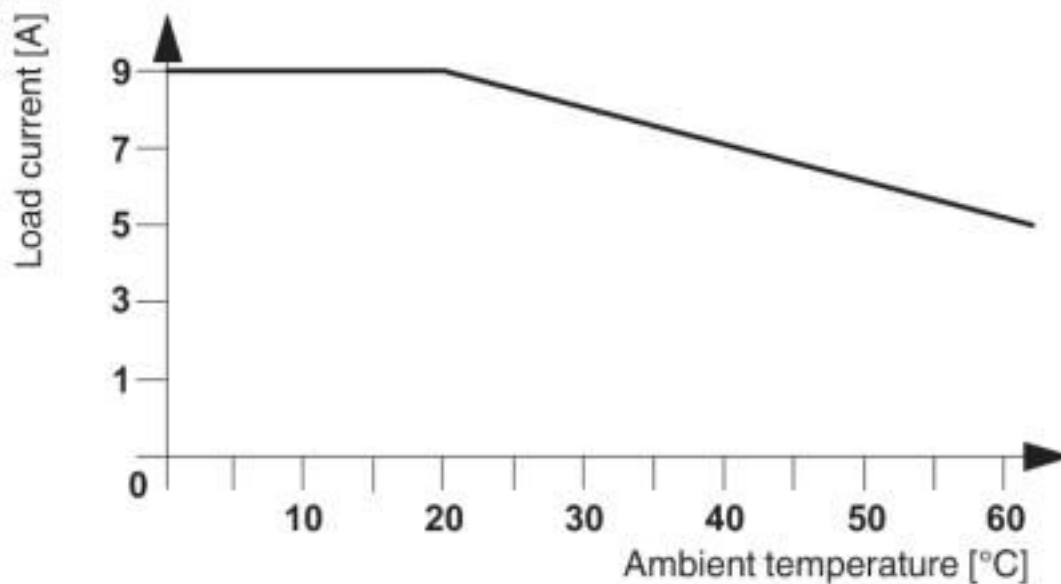

# Load relay - ELR 3/ 9-500 - 2941714

Diagram

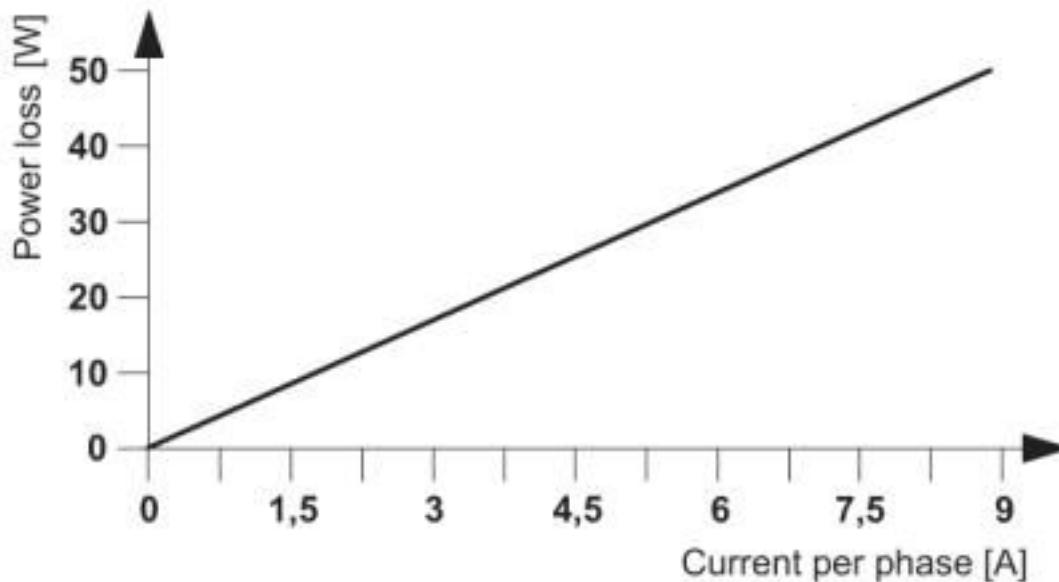

## Classifications

eCl@ss

eCl@ss 10.0.1	27371014
eCl@ss 4.0	27371100
eCl@ss 4.1	27371100
eCl@ss 5.0	27371000
eCl@ss 5.1	27371000
eCl@ss 6.0	27371000
eCl@ss 7.0	27371014
eCl@ss 8.0	27371014
eCl@ss 9.0	27371014

ETIM

ETIM 4.0	EC002055
ETIM 5.0	EC002055
ETIM 6.0	EC002055
ETIM 7.0	EC002055

UNSPSC

UNSPSC 6.01	30211915
UNSPSC 7.0901	39121514
UNSPSC 11	39121514
UNSPSC 12.01	39121514
UNSPSC 13.2	39121529
UNSPSC 18.0	39122333

# Load relay - ELR 3/ 9-500 - 2941714

## Classifications

### UNSPSC

UNSPSC 19.0	39122333
UNSPSC 20.0	39122333
UNSPSC 21.0	39122333

## Approvals

### Approvals

---

Approvals

EAC

---

Ex Approvals

---

### Approval details

EAC		TR_TS_D_00573_c
-----	---	-----------------

Phoenix Contact 2020 © - all rights reserved  
<http://www.phoenixcontact.com>

PHOENIX CONTACT GmbH & Co. KG  
Flachsmarktstr. 8  
32825 Blomberg  
Germany  
Tel. +49 5235 300  
Fax +49 5235 3 41200  
<http://www.phoenixcontact.com>

# Mouser Electronics

Authorized Distributor

Click to View Pricing, Inventory, Delivery & Lifecycle Information:

[Phoenix Contact:](#)

[2941714](#)